

SVS

The easy way to machine vision



DATASENSOR
value through detection

WHERE SVS CAN SOLVE ALL YOUR PROBLEMS



The innovative versatility and excellent performances make the **SVS** smart vision sensors series the most reliable and advantageous solution for the most common application problems of the main industrial markets: **automotive and food plants, pharmaceutical and cosmetic packaging, electronic assembling and postal automation.**

SVS has been developed specifically to solve typical applications in packaging, bottling, labelling, assembling and testing of products and semi-finished parts.

A simple solution able to control the cap presence on a plastic bottle, the shape of coffee waffles, count chocolates on a tray, check the filling level of medical phials, control the presence of an expiry date or manufacturing lot on food packages.

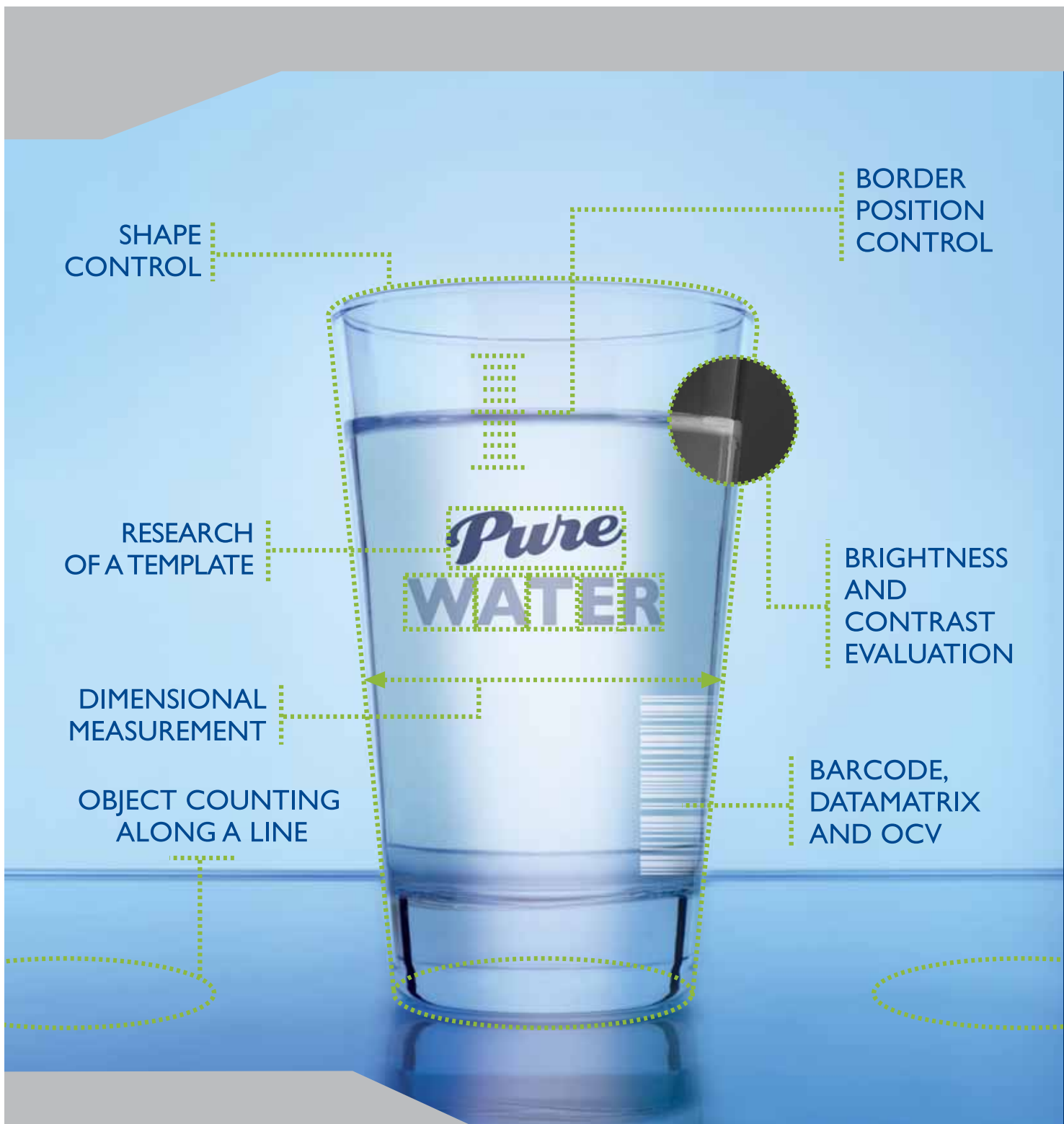

The SVS series of smart vision sensors offers the easiest way to solve the most common **machine vision** applications. A simple solution for packaging lines, food and beverage industries, automotive and electronics plants. The SVS series combines sophisticated technology with extremely simple functioning and thus represents the best easy-to-use solution to all vision control applications.

SVS1 and SVS2 offer two different application approaches:

- the SVS1 model guarantees the quickest and easiest setup via hand-held configurator;
- the SVS2 can be connected to a PC and offers multiple controls on the same application.

The SVS is an intelligent camera. The SVS sensor is fully embedded, still remaining extremely compact. Both models, after configuration, can function standing alone without external control units.

SVS is the right solution when normal photoelectric sensors are not able to meet application requirements and represents a cost-effective and simple alternative to the traditional vision systems.

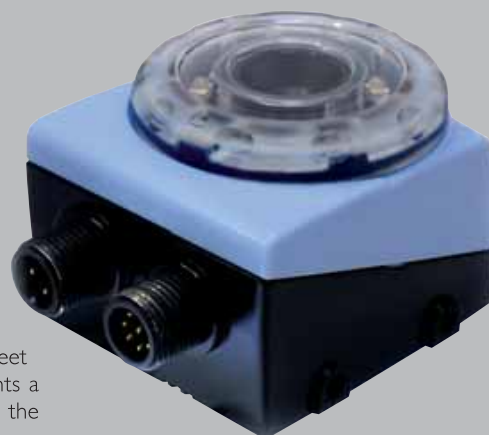

WHAT SVS CAN DO FOR YOU

The simple functioning and quick installation represent extremely important characteristics of the SVS vision family. Simplicity, however, does not mean limited functionalities and reduced performances. The SVS sensors are equipped with the most advanced vision algorithms: 360° geometric pattern match, contour match, Datamatrix, OCV and much more.



The wide range of image processing techniques is able to solve the most common industrial automation applications:

- part orientation control;
- part presence check;
- object counting;
- check of the correct assembling;
- code and character reading;
- shape control.



Pattern Match

Packaging:
logo check
Assembling:
product orientation
Post automation:
stamp check



Contour Match

Metal working:
integrity control
Food:
coffee waffle shape control



Position

Bottling:
liquid level control
Food:
label position control



Width

Assembling:
plastic part control
Wood industry:
branch thickness measurement

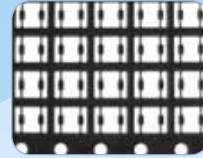

Counting

Electronics:
component counting
Pharmaceutical:
blister stack counting



Contrast

Food:
date and lot presence control
Metal working:
laser marking control



Brightness

Bottling:
cap presence control
Packaging:
object counting



Barcode

Pharmaceutical:
chemical and biomedical analysis
Postal:
document/letter processing
Food:
semi-finished part tracking



Datamatrix

Electronics:
PCB movement
Automotive:
tyre sorting
Pharmaceutical:
phial sorting

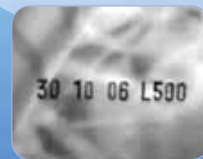

OCV - character check

Food:
date and lot presence control
Pharmaceutical:
date and lot presence control

UNIQUE 360° OBJECT RECOGNITION

SVS is the only vision sensor in its market segment able to offer an image processing tool that recognises objects on the field of view independently from the rotations. The Geometric Pattern Match has been especially developed to store during setup the actual characteristics of the object to be tracked and to recover them during functioning with total tolerance to position and orientation changes.



HOW SVS WORKS FOR YOU

The extremely compact size of the **SVS** sensors is not an obstacle for the full integration of all the elements for a reliable image-based control. The concept at the base of all vision applications consists in the object comparison with a faultless template image.

The **image sensor** with 640x480 pixel resolution functions in an 8 bit grey scale and is able to acquire up to 60 images per second.

The **integrated** red light LED based **illuminator** ensures excellent light control on the field of view.

The front **focus knob** offers precise focussing.

The **integrated interface** is composed of 4 signalling LEDs and a teach-in button. The latter has a double function: template image updating and sensor unlock.

The **lenses** are built-in and can be selected according to the model, guaranteeing flexible installation as far as the operating distance and field of view are concerned.

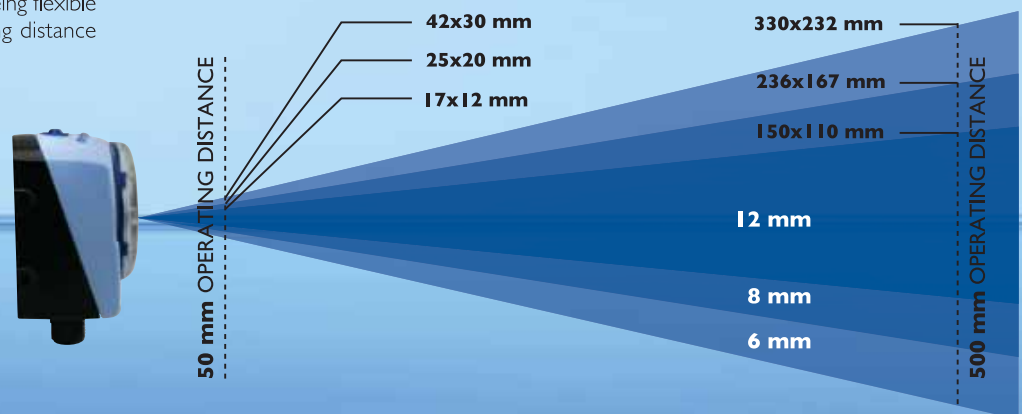

Technical specifications

Power supply	24 Vdc \pm 10%
Consumption (excluding output current and illuminator)	100 mA at 24 Vdc
Outputs	3 PNP outputs - 1 strobe signal
Inputs	1 input per inspection selection - 1 trigger input
Network interface	MI2 4-poles - 10/100 Mbps Ethernet
External illuminator interface	Strobe signal (TTL)
Output current	100 mA max
Saturation voltage	< 2 V
Integrated optics	6, 8, 12mm
Resolution	640x480 (VGA)
Frame rate	60fps
Dimensions	69,8 x 51,5 x 40 mm
Indicators	4 LEDs
Setting	1 teach-in button
Data retention	20 slot FLASH non-volatile memory
Operating temperature	-10 °C / +55 °C
Storage temperature	-25 °C / +75 °C
Housing material	Die-cast aluminium / ABS
Mechanical protection	IP50
Connections	MI2 8 poles A-code, MI2 4-poles D-code
Weight	125 g



WHICH SVS SOLUTION



Artificial vision is now closer than ever to the photoelectric sensor world thanks to **SVS1** sensors. The possibility of activating a quality control without using a PC makes **SVS1** a real smart vision sensor.

The setup is obtained thanks to the **VSC hand-held configurator** equipped with a 3.5" colour LCD display and integrated keyboard. **VSC** presents standard 96x96 dimensions and can be easily installed on a panel or on a DIN rail. Three simple steps allow the definition of the control area, the selection of the processing tool and the fixing of the acceptance threshold.

The sensor is completely embedded. Once completed the parameterisation, the **VSC** can be used to monitor sensor functioning and visualise diagnostics or can be disconnected and used with other sensors.

SVS1 represents the ideal solution for lines characterised by frequent manufacturing changes. Once installed and configured, the sensor updating requires only the acquisition of a new template using the configurator.



- IMMEDIATE SETUP WITHOUT PC
- VSC CONFIGURATOR WITH 3.5" LCD DISPLAY
- COMPLETELY EMBEDDED SENSOR
- STAND-ALONE FUNCTIONING
- REAL TIME MONITORING
- OBJECT RECOGNITION TOOLS
- OCV

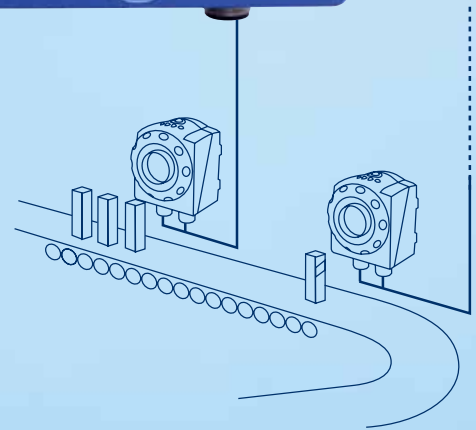

VSC configuration

Setup

The setup mode allows the configuration of the image quality parameters, selects and re-sizes the control area and chooses the processing tool to use.

Adjust

The Adjust mode allows to regulate the acceptance thresholds to establish a safe and reliable waste condition.

Monitor

The Monitor mode allows both to visualise the images during normal sensor functioning as well as to control the diagnostics linked to inspection results.



IS THE BEST FOR YOU



The **SVS2** series of vision sensors offers all the characteristics able to solve machine vision problems in a flexible and intuitive manner. The **SVS2** is configured **using a PC** and the sensor functions in a stand-alone mode.

SVS2 communicates with the PC via Ethernet. The sensor's IP address is automatically found by the Discovery function. The interface software is supplied with the product and has been studied to guide step-by-step the user in the creation of an image inspection.

SVS2 is available in three versions characterised by different processing software: **SVS2** Object Recognition, **SVS2** Advanced Object Recognition and **SVS2** Identification.

SVS2 combines simplicity and versatility. The sensor can store up to 20 different inspections, each of which can contain multiple controls on the same image.

One sensor alone is able to contemporarily carry-out different controls on the same object, thus reducing installation time.

- VERSATILE PC SETUP
- WIZARD-BASED SOFTWARE
- ETHERNET COMMUNICATION
- OBJECT RECOGNITION OR IDENTIFICATION TOOLS
- 360° PATTERN MATCH
- MONITORING AND TUNING VIA VSM MONITOR
- MULTIPLE CONTROLS
- IP DISCOVERY FUNCTION

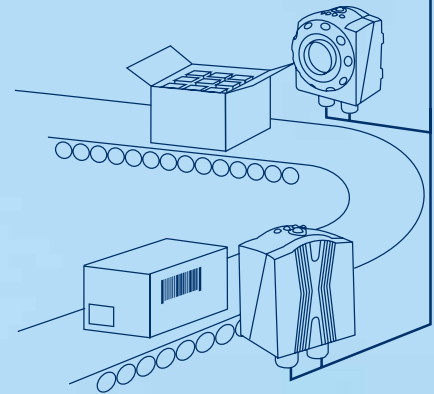

PC configuration



Image Setup

The first step consists in connecting the sensor and configuring the image quality parameters. When the desired results are obtained, the user can memorise the image that will be used as a template during sensor functioning.



Teach

The second step establishes the acceptance criteria to distinguish objects from wastes. One or more controls can be selected according to the task to carry-out.



Run

The third step configures the sensor digital outputs, simulates sensor functioning on the PC to verify the controls chosen and activates the operating phase on the sensor using the PC only to control the diagnostics.



VSM MONITOR

The **SVS2** models present a multifunction **VSM** monitor that allows to display images, change some parameters and extend, thanks to the built-in additional memory, the number of selectable inspections. The **VSM** cannot create a new inspection and can be used only with **SVS2** models as it is not compatible with **SVS1** models.

Models and functions

Model	CONNECTIVITY				I/O	TOOLS			
	Ethernet	VSC	VSM	RS232		360° PM	OBJ	Codes	OCV
SVS1-08-DC-K*		•			3 outputs 2 inputs		•		•
SVS1-06-DC-S*		•			3 outputs 2 inputs		•		•
SVS1-08-DC-S*		•			3 outputs 2 inputs		•		•
SVS1-12-DC-S*		•			3 outputs 2 inputs		•		•
SVS2-06-DE-AOR	•		•		3 outputs 2 inputs	•	•		
SVS2-08-DE-AOR	•		•		3 outputs 2 inputs	•	•		
SVS2-12-DE-AOR	•		•		3 outputs 2 inputs	•	•		
SVS2-06-DE-OBJ	•		•		3 outputs 2 inputs		•		
SVS2-08-DE-OBJ	•		•		3 outputs 2 inputs		•		
SVS2-12-DE-OBJ	•		•		3 outputs 2 inputs		•		
SVS2-06-RE-ID	•		•	•	2 outputs 1 input			•	•
SVS2-08-RE-ID	•		•	•	2 outputs 1 input			•	•
SVS2-12-RE-ID	•		•	•	2 outputs 1 input			•	•

The SVS1-K model includes sensor and VSC configurator; the SVS1-S models include only the sensor;
 360° PM: 360° Pattern Match
 OBJ: Object Recognition (Brightness, Contrast, Width, Position, Contour Match, Pattern Match, Edge Count)
 Codes: Barcode and Datamatrix
 OCV: Optical Character Verification
 VSM : monitor for SVS2 models

Dimensions (mm)

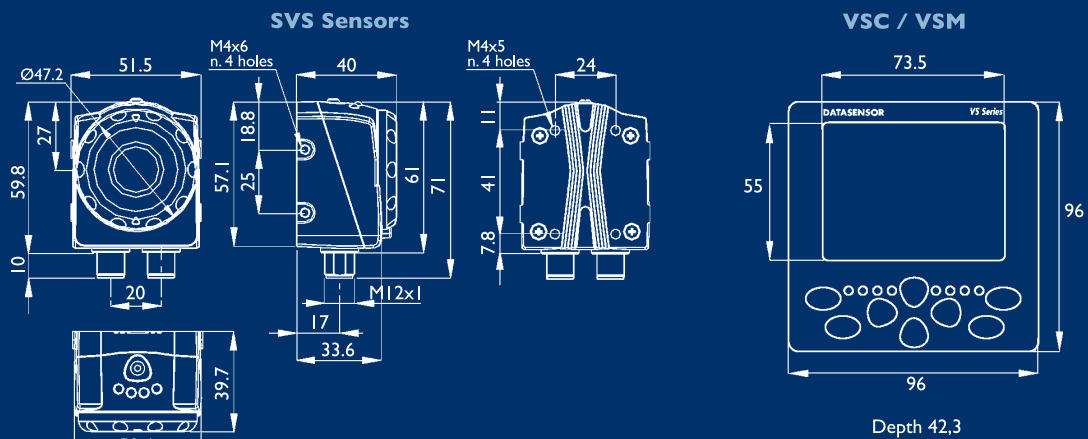

9CS01619E - Printed in Italy, December 2008



www.datasensor.com