

Enabling Switches



Selection Guide..... 403

HE1B Series Basic Enabling Switch..... 404

HE2B Series Redundant (Double) Basic Enabling Switch 407

HE3B Series Pushbutton Enabling Switch.. 410

HE5B Series Pushbutton Enabling Switch.. 413

HE1G Series Grip Style Enabling Switch.... 416

General Information 419

Overview

X Series E-Stops

Door Interlock Switches

Enabling Switches

Barriers

As-Interface Safety at Work



For more information on this product family, visit our website.

Additional resources include:

- New and updated product information
- Downloadable software demos & upgrades
- Part configuration tool & cross reference
- Online stock check & ordering
- IDEC field sales & distributor search
- Online literature request
- Downloadable manuals & CAD drawings
- Manufacturer's suggested retail price list
- Product training schedule & locations
- Advertising & trade show schedules
- Press releases & FAQs

www.idec.com/safety

Enabling “Dead Man” Switches

What is an enabling switch?

An enabling switch is a 3-position (OFF-ON-OFF) switch to allow a machine operation only when the switch is lightly pressed and held in the middle position (position 2). Because it disables machine operation when released (position 1) or further depressed (position 3) by a panicked operator, the safety of operators is ensured.

Because operators use pendants in hazardous environments performing teaching, system changeover, and maintenance of robots, they must have protection against unpredictable motion of robots, and therefore teach pendants are equipped with 3-position enabling switches.

Overview

X Series E-Stops

Door Interlock Switches

Enabling Switches

Barriers

AS-Interface Safety at Work



Selection Guide

Enabling Switches

Series Model	HE1B	HE2B	HE3B	HE5B	HE1G
Appearance					
Page	404	407	410	413	416
Description	Basic Switch	Redundant Basic Switch	16mm Panel Mount	16mm Round Enabling Switch	Grip Switch
Maximum Contacts	1NO	DPDT/DPDT, 2NC/DPDT, 4NC	DPDT	DPDT	DPDT, 1NC/DPDT, 2NC

Overview

X Series E-Stops

Application Example



Door Interlock Switches

Enabling Switches

HE1B Enabling Switch Movement

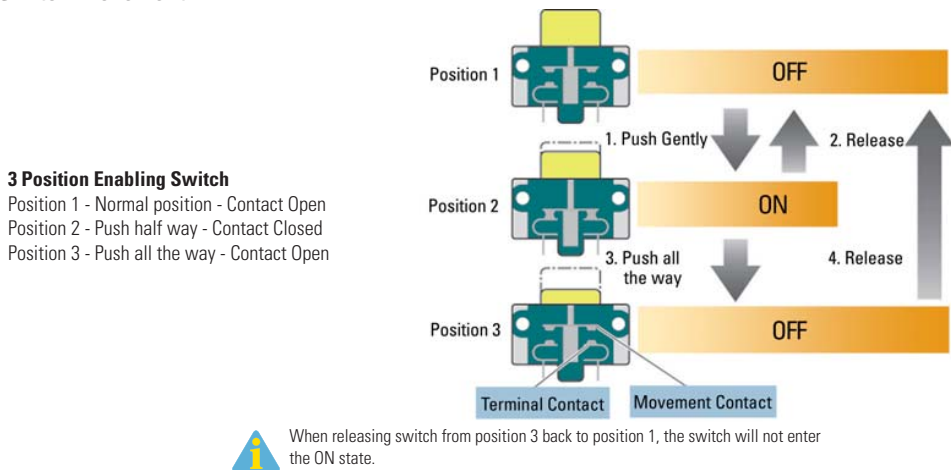

Barriers

AS-Interface Safety at Work

HE1B Series Basic Enabling Switch

HE1B Key features include:

- 3 position functionality (OFF – ON –OFF) as required for manual robotic control
- Ideally suited for use as enabling (aka “deadman”) switch on teach pendants
- Provides a high level of safety based on human behavioral studies that determine personnel may squeeze OR let go when presented with a panic situation
- Positive action contacts “On” (pos. 2) to “Off” (pos. 3) ensure no contact welding (per EN60947-5-1 / IEC60947-5-1)
- Contacts will not close when released from “Off” (pos. 3) to “Off” (pos. 1) (per IEC60204-1; 9.2.5.8)
- Small, lightweight and highly reliable



Overview

X Series E-Stops



Door Interlock Switches

Specifications

Conforming to Standards	IEC60947-5-1, EN60947-5-1, JIS C8201-5-1, UL508, CSA C22.2 No 14	
Operating Temperature	–25 to +60°C (no freezing)	
Operating Humidity	45 to 85% RH maximum (no condensation)	
Storage Temperature	–40 to +80°C (no freezing)	
Pollution Degree	2	
Initial Contact Resistance	50mΩ maximum	
Insulation Resistance	100MΩ minimum	
Impulse Withstand Voltage	2.5kV	
Operating Frequency	1200 operations/hour	
Mechanical Life	Position 1→2: 1,000,000 operations minimum Position 1→2→3→1: 100,000 operations minimum	
Electrical Life	100,000 operations minimum at rated load	
Shock Resistance	Operating Extremes	100m/s ² (10G)
	Damage Limits	1000m/s ² (100G)
Vibration Resistance	Operating Extremes	5 to 55Hz, amplitude 0.5mm minimum
	Damage Limits	16.7Hz, amplitude 1.5mm minimum
Terminal Shape	Solder Terminal	
Recommended Wire	0.5mm ² maximum / 1 line (20AWG)	
Solder Heat Resistance	260°C / 3 seconds maximum	
Terminal Pulling Strength	20N minimum	
Recommended Screw Torque	HE1B-M1: M3 screw / 0.5 to 0.8Nm	
Degree of Protection	IP40 (IEC 60529) excluding terminal part	
Conditional Short-Circuit Current	50A (250V)	
Recommended Short Circuit Protection	250V, 10A fast blow fuse (IEC 60127-1)	
Weight	Approx. 6g	
Circuit Opening Force	30N minimum (position 2→3)	
Control Resistance (Operating)	250N minimum	

Enabling Switches

Barriers

AS-Interface Safety at Work

Part Numbers

Item	Installation	Part Number
	Side	HE1B-M1
	Front	HE1B-M1N

Current Ratings

Rated Insulation Voltage (Ui)		AC / DC250V			
Thermal Current (Ith)		5A			
Rated Operating Voltage (Ue)		30V	125V	250V	
Rated Operating Current (Ie)	AC 50/60Hz	Resistive Load (AC-12)	–	3A	1.5A
		Inductive Load (AC-15)	–	1.5A	0.75A
	DC	Resistive Load (DC-12)	2A	0.4A	0.2A
		Inductive Load (DC-13)	1A	0.22A	0.1A
Contact Structure		SPST-NO three position (OFF-ON-OFF)			

Minimum applicable load: AC/DC3V • 5mA (For reference only).

Operating Characteristics

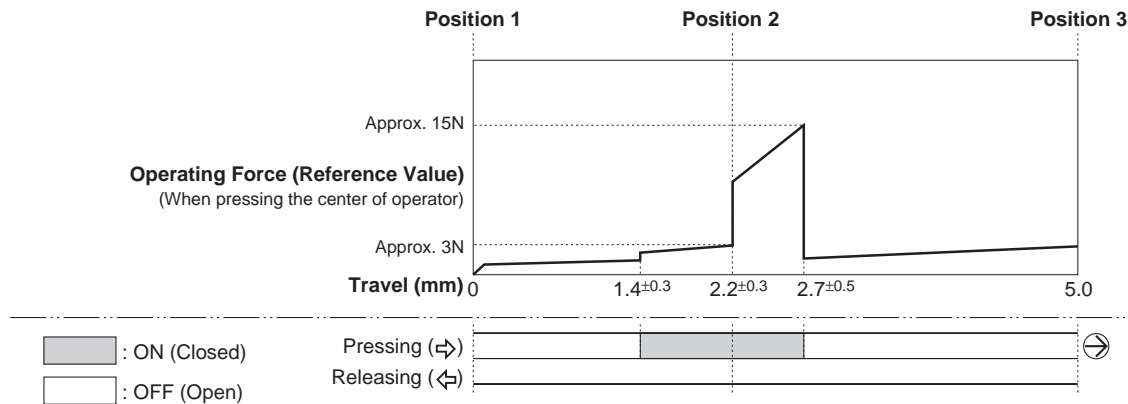

Overview

X Series E-Stops

Door Interlock Switches

Enabling Switches

Barriers

AS-Interface Safety at Work

Dimensions (mm)

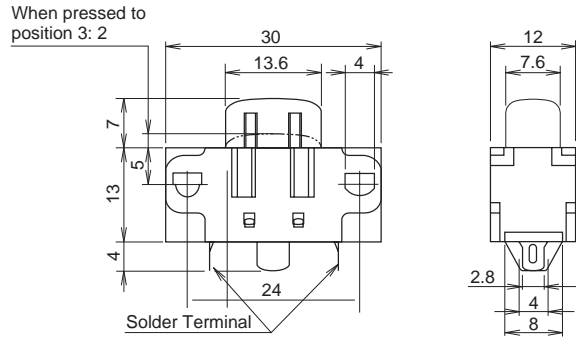

Installation Dimensions (mm)

HE1B-M1 (Side Mounting)

- 1. M3 Screw (not provided)
- 2. Thread built in

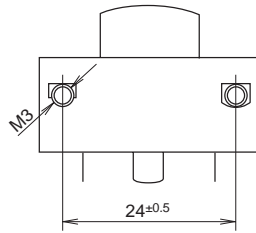

HE1B-M1N (Front Mounting)

- 1. M3 Screw (not provided)
- 2. Locking nut (2 pcs) included

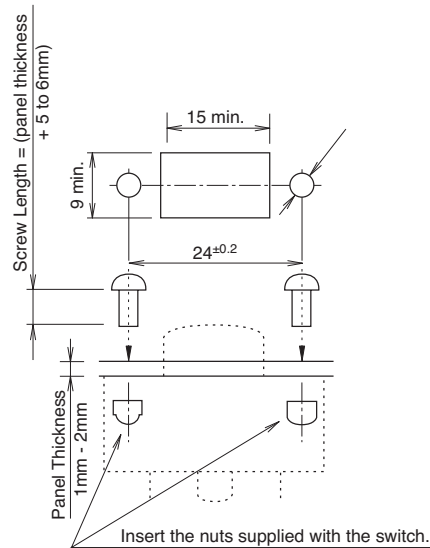

When using a panel thicker than 2mm, the button will be lower than the surface of the panel

Overview

X Series E-Stops

Door Interlock Switches

Enabling Switches

Barrires

AS-Interface Safety at Work

HE2B Series Redundant (Double) Basic Enabling Switch

HE2B Key features include:

- 3 position functionality (OFF – ON –OFF) as required for manual robotic control
- Ideally suited for use as enabling (aka “deadman”) switch on teach pendants
- Provides a high level of safety based on human behavioral studies that determine personnel may squeeze OR let go when presented with a panic situation
- Snap acting contacts from Off→On (1→ 2)
- Positive action contacts from On→Off (2→ 3) ensure no contact welding (per EN60947-5-1 / IEC60947-5-1)
- Contacts will not re-close when released from Off→On (3→1) (per IEC60204-1; 9.2.5.8)
- Multiple contacts for enhanced reliability
- Monitoring contacts in addition to main load contacts
- Available with or without rubber cover (cover provides IP65 watertight seal)



Overview

X Series E-Stops



Specifications

Conforming to Standards	IEC60947-5-1, EN60947-5-1, JIS C8201-5-1, UL508, CSA C22.2 No 14
Application Standards	ISO12100/EN292, IEC60204-1/EN60204-1, ISO11161/prEN11161, ISO10218/EN775, ANSI/RIA R15.06
Operating Temperature	-25 to +60°C (no freezing)
Operating Humidity	45 to 85% RH (no condensation)
Storage Temperature	-40 to +80°C (no freezing)
Pollution Degree	2 (inside of panel/contact side) 3 (outside of panel/operating side)
Contact Resistance	50mΩ maximum
Insulation Resistance	Between live and dead metal parts: 100MΩ maximum Between positive and negative live parts: 100MΩ minimum
Impulse Withstand Voltage	2.5kV
Operating Frequency	1200 operations/hour
Mechanical Life	Position 1→2: 1,000,000 operations minimum Position 1→2→3→1: 100,000 operations minimum
Electrical Life	100,000 (at full rated load)
Shock Resistance	Operating Extremes 100m/s ² (10 G) Damage Limits 1000m/s ² (100 G)
Vibration Resistance	Operating Extremes 5 to 55Hz, amplitude 0.5mm minimum Damage Limits 16.7Hz, amplitude 1.5mm minimum
Terminal	0.110" quick connect / solder terminal
Recommend Wire Size	0.5mm ² maximum / 1 line (20AWG)
Solder Heat Resistance	260°C / 3 seconds maximum
Terminal Pulling Strength	20N minimum
Recommended Screw Torque	0.5 to 0.8Nm
Degree of Protection	with rubber cover: IP65, without rubber cover: IP40 (IEC 60529),
Conditional Short-Circuit Current	50A (250V)
Recommended Short Circuit Protection	250V/10A fast blow fuse (IEC 60127-1)
Weight	Approx. 26g (without cover), 30g (with cover)
Circuit Opening Force	60N minimum (button return monitor & button push monitor)
Actuating Force (Operating)	500N minimum

Ordering Information

HE2B - M 2 0 0 P Y

3 Position Switch
2: 2 contacts (DPDT)

Rubber Cover Color
None: without cover
Y: Yellow
B: Black

Rubber Cover
None: without cover
P: with cover

Return Monitor Switch
0: None
1: 1 contact
2: 2 contacts



Door Interlock Switches

Enabling Switches

Barriers

AS-Interface Safety at Work

Part Numbers

Model	Number of Contacts			Part Number
	3 Position Switch	Push Monitor Switch	Return Monitor Switch	
 Without Rubber Cover	2	0	0	HE2B-M200
	2	1	1	HE2B-M211
	2	2	2	HE2B-M222
 With Rubber Cover	Yellow	2	0	HE2B-M200PY
		2	1	HE2B-M211PY
		2	2	HE2B-M222PY
	Black	2	0	HE2B-M200PB
		2	1	HE2B-M211PB
		2	2	HE2B-M222PB

Overview

X Series E-Stops

Ratings

Contact Ratings

Rated Insulation Voltage (Ui)				250V		
Thermal Current (Ith)				3A		
Rated Operating Voltage (Ue)				30V	125V	250V
Rated Operating Current (Ie)	3 Position Switch	AC	Resistive Load (AC-12)	–	1A	0.5A
			Inductive Load (AC-15)	–	0.7A	0.5A
		DC	Resistive Load (DC-12)	1A	0.2A	–
			Inductive Load (DC-13)	0.7A	0.1A	–
	Push/return Monitor Switch (NC Contacts)	AC	Resistive Load (AC-12)	–	2A	1A
			Inductive Load (AC-15)	–	1A	0.5A
		DC	Resistive Load (DC-12)	2A	0.4A	0.2A
			Inductive Load (DC-13)	1A	0.22A	0.1A
Contact Structure	3 Position Switch		2 contacts (DPDT)			
	Button Return Monitor Switch		0 to 2 contacts			
	Button Push Monitor Switch		0 to 2 contacts			

Door Interlock Switches

Enabling Switches



Minimum applicable load (reference) = AC/DC3V • 5mA (for reference only)

Circuit Diagrams

Terminal Circuit Diagrams (bottom view)

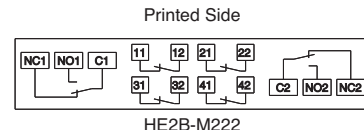
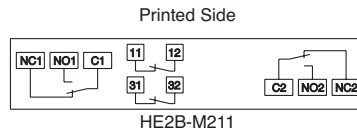
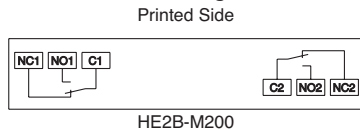

Barriers

AS-Interface Safety at Work

Operating Characteristics

Operating Characteristics (without rubber cover/center of button being pushed)

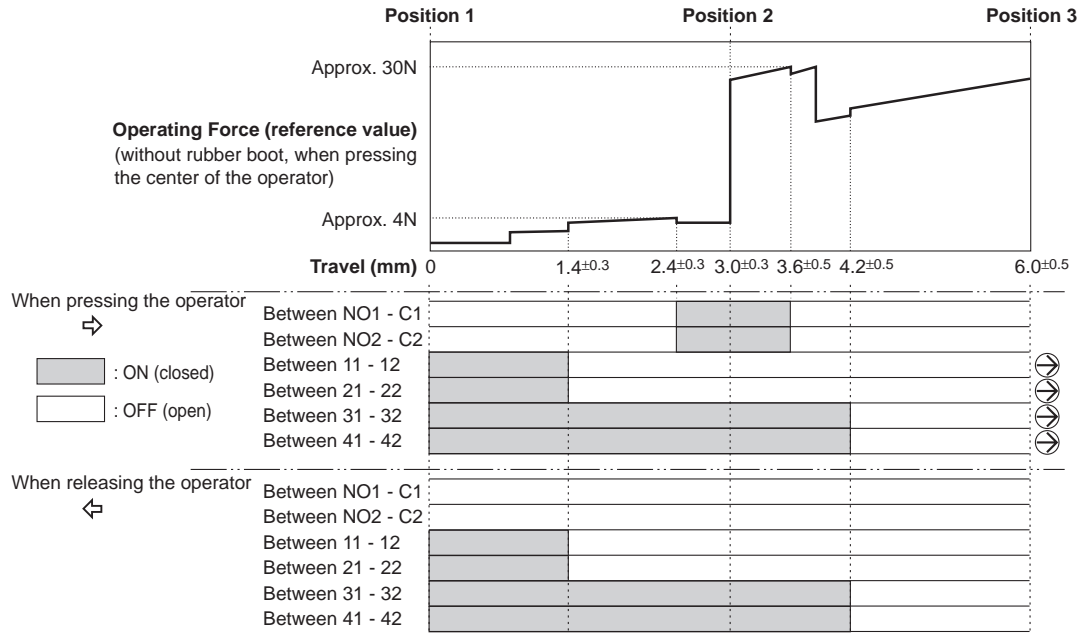

Using rubber cover will change the operating load because the operating temperature would increase

Dimensions (mm)
Without Rubber Cover

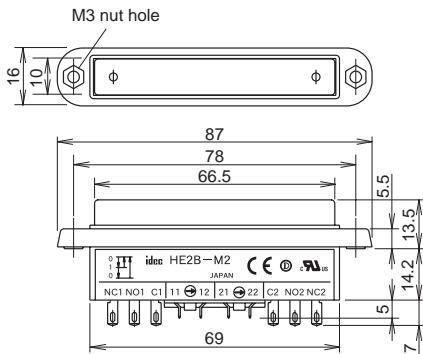

With Rubber Cover

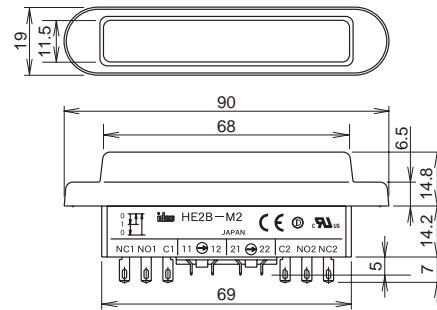

Mounting Hole Layout

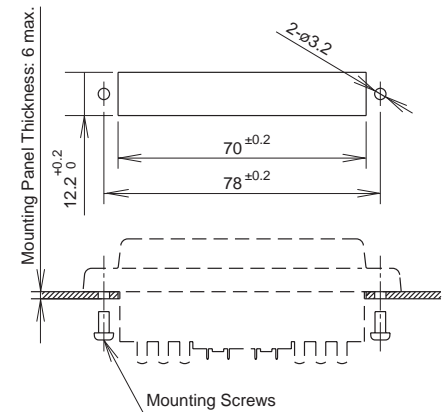

Accessories
Replacement Rubber Cover

Appearance	Color	Part Number	Material
	Yellow	HE9Z-D2Y	Silicon Rubber
	Black	HE9Z-D2B	

Overview

X Series E-Stops

Door Interlock Switches

Enabling Switches

Barriers

AS-Interface Safety at Work

HE3B Series Pushbutton Enabling Switch

HE3B Key features include:

- 3 position functionality (OFF – ON – OFF) as required for manual robotic control
- Provides a high level of safety based on human behavioral studies that determine personnel may squeeze OR let go when presented with a panic situation
- Contacts will not re-close when released from Off→On (3→1) (per IEC60204-1; 9.2.5.8)
- Multiple contacts for enhanced reliability
- Snap acting contacts from position 1 to 2
- Available with or without rubber cover



Specifications

Conforming to Standards	IEC60947-5-1, EN60947-5-1, JIS C8201-5-1, UL508, CSA C22.2 No 14
Application Standards	ISO12100/EN292, IEC60204-1/EN60204-1, ISO11161/prEN11161, ISO10218/EN775, ANSI/RIA R15.06
Operating Temperature	-25 to +60°C (no freezing)
Operating Humidity	45 to 85% RH maximum (no condensation)
Storage Temperature	-40 to +80°C (no freezing)
Pollution Degree	3
Contact Resistance	50mΩ maximum
Insulation Resistance	Between live & dead metal parts: 100MΩ maximum
	Between positive & negative live parts: 100MΩ minimum
Impulse Withstand Voltage	1.5kV
Operating Frequency	1200 operations/hour
Mechanical Life	Position 1→2: 1,000,000 operations minimum
	Position 1→2→3→1: 100,000 operations minimum
Electrical Life	100,000 operations minimum at rated load
Shock Resistance	Operating Extremes 100m/s ² (10 G)
	Damage Limits 1000m/s ² (100 G)
Vibration Resistance	Operating Extremes 5 to 55Hz, amplitude 0.5mm minimum
	Damage Limits 16.7Hz, amplitude 1.5mm minimum
Terminal	0.110" quick connect / solder terminal
Recommended Wire Size	0.5mm ² maximum / 1 line (20AWG)
Solder Heat Resistance	260°C / 3 seconds maximum
Terminal Pulling Strength	20N minimum
Recommended Screw Torque	0.68 to 0.88Nm
Degree of Protection	with rubber cover: IP65, without rubber cover: IP40 (IEC 60529)
Conditional Short-Circuit Current	50A (125V)
Recommended Short Circuit Protection	125V/10A fast blow fuse (IEC 60127-1)
Weight	without rubber cover - Approx. 14g with rubber cover - Approx. 18g
Circuit Opening Force	500N minimum

Overview

X Series E-Stops



Door Interlock Switches

Enabling Switches

Barriers

AS-Interface Safety at Work

Part Numbers

Model	Contact Arrangement	Part Numbers	
 Without Rubber Cover	DPDT	HE3B-M2	
 With Rubber Cover		Yellow	HE3B-M2PY
		Black	HE3B-M2PB

Contact Ratings

Rated Insulation Voltage (Ui)		125V	
Thermal Current (Ith)		3A	
Rated Operating Voltage (Ue)		30V	125V
Rated Operating Current (Ie)	AC	Resistive Load (AC-12)	1A
		Inductive Load (AC-15)	0.7A
	DC	Resistive Load (DC-12)	0.2A
		Inductive Load (DC-13)	0.1A
Contact Structure (3 Position Switch)		2 contacts (DPDT)	

Circuit Diagrams

Terminal Circuit Diagrams (bottom view)

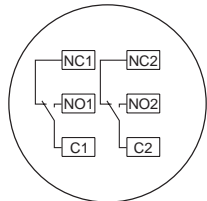

- 1. 3 position switch: 2 contacts, terminal no. = between N01-C1, between N02-C2
- 2. Use between NO-C for OFF→ On→ OFF 3 position switch (NC is not used).

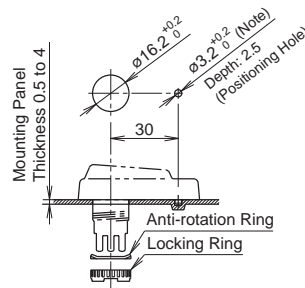

- 1. Recommended Lock Nut Torque: 0.68 to 0.88Nm.
- 2. Use a lock nut tool to screw on the lock nut (see page 412).
- 3. To retain the switches waterproof performance, do not penetrate the rubber cover.
- 4. Remove the rubber cover projection if you do not want a positioning hole. (Do not penetrate the rubber cover).

Operating Characteristics

Operating Characteristics (without rubber cover/pushing button part A and B)

Overview

X Series E-Stops

Door Interlock Switches

Enabling Switches

Barriers

AS-Interface Safety at Work

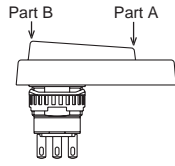

Operating Force (reference value)
(Without rubber boot)
(When part A or part B is pressed)

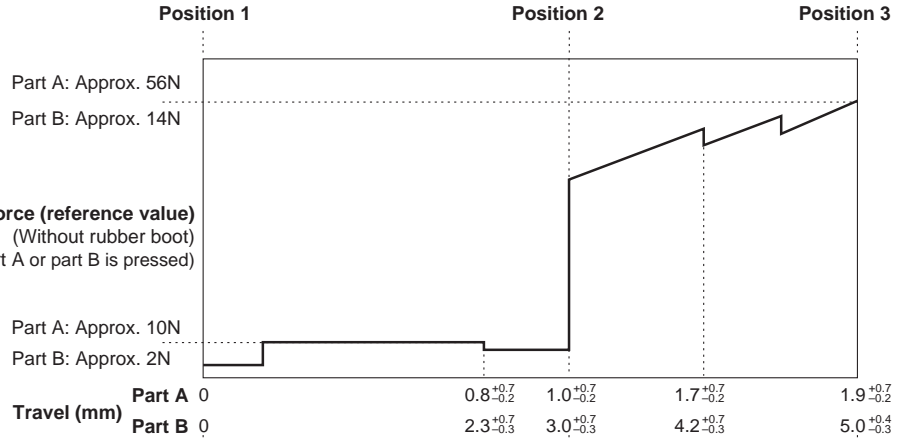

When pressing the operator	Between NO1 – C1	Between NO2 – C2
ON (closed)	ON	ON
OFF (open)	OFF	OFF

When releasing the operator	Between NO1 – C1	Between NO2 – C2
ON (closed)	OFF	OFF
OFF (open)	ON	ON

Notes:
• When rubber boot is used, operating force depends on the operating temperature.

Dimensions (mm)
Without Rubber Cover

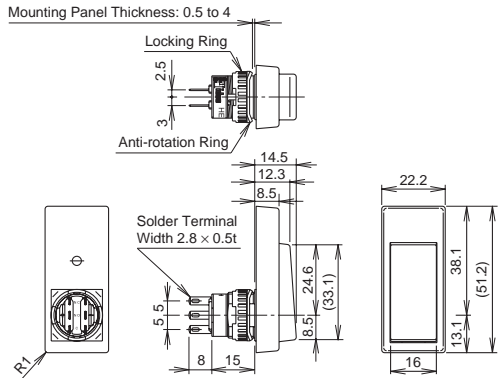

With Rubber Cover

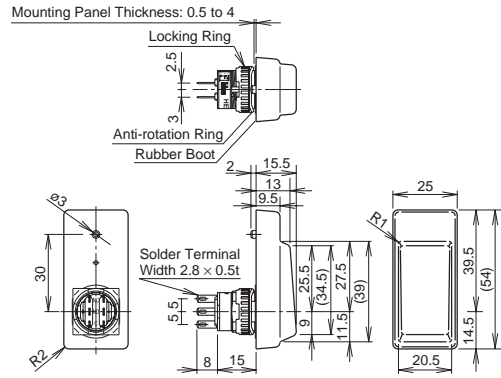

All dimensions in mm.

Accessories
Replacement Rubber Cover

Appearance	Color	Part Number	Material
	Yellow	HE9Z-D3Y	Silicon Rubber
	Black	HE9Z-D3B	

Lock Nut Tool

Appearance	Part Number	Material
	MT-001	Metal

HE5B Series Pushbutton Enabling Switch

HE5B Key features include:

- Ergonomically-designed OFF-ON-OFF 3-position operation
- Easy recognition of position 1 → 2 transition, made possible by snap action switch
- Sufficient load difference is provided for shifting from position 2 → 3
- Light force needed to maintain position 2, so that operators can easily use the enabling switch
- The switch does not turn ON when being released from position 3 (OFF when pressed) to position 1 (OFF when released) (IEC60204-1, 9.2.5.8)
- Two contacts are provided for safety
- IP65 (using the waterproof rubber cover)
- Mounts in a 16mm (5/8”) round hole



Overview

X Series E-Stops

Door Interlock Switches

Enabling Switches

Barriers

AS-Interface Safety at Work

Specifications

Conforming to Standards	IEC60947-5-1, EN60947-5-1 (DEMKO approval), JIS C8201-5-1, UL508 (UL recognized), CSA C22.2, No. 14 (c-UL recognized)
Application Standards	ISO 12100/EN292, IEC60204-1/EN60204-1 ISO11161/prEN11161, ISO10218/EN775 ANSI/RIA R15.06, ANSI B11.19
Operating Temperature	Silicone rubber boot: -25 to 60°C (no freezing) NBR/PVC Polyblend rubber boot: -10 to 60°C (no freezing)
Relative Humidity	45 to 85% RH (no condensation)
Storage Temperature	-40 to +80°C (no freezing)
Operating Environment	Degree of pollution: 2 (panel inside/terminal side) Degree of pollution: 3 (panel outside/operator side)
Contact Resistance	50 mΩ maximum (initial value)
Insulation Resistance (DC megger)	Between live and dead metal parts: 100 MΩ minimum Between terminals of different pole: 100 MΩ minimum
Impulse Withstand Voltage	1.5 kV
Operating Frequency	1200 operations per hour
Mechanical Life	Position 1 → 2 → 1: 1,000,000 operations minimum Position 1 → 2 → 3 → 1: 100,000 operations minimum
Electrical Life	100,000 operations minimum
Shock Resistance	Operating extremes: 100 m/s ² (10 G) Damage limits: 500 m/s ² (50 G)
Vibration Resistance	Operating extremes: 5 to 55 Hz, amplitude 0.5 mm minimum Damage limits: 5 to 55 Hz, amplitude 0.5 mm minimum
Terminal Style	Solder Terminal
Recommended Wire	0.5 mm ² maximum per line (20AWG)
Solder Heat Resistance	260°C, 3 seconds maximum
Terminal Pulling Strength	20 N minimum
Recommended Tightening Torque of Locking Ring	0.29 to 0.49 N·m
Degree of Protection	IP65
Conditional Short-circuit Current	50A (250V) (Use 250V/10A fast acting type fuse for short circuit protection.)
Operator Strength	250N minimum (when pressing the entire surface of the operator)
Weight (approx.)	9 g

Part Numbers

Model		Contact Arrangement	Color	Part Number
With Rubber Cover	Silicone Rubber	DPDT	Yellow	HE5B-M2PY
			Black	HE5B-M2PB
	NBR/PVC		Gray	HE5B-M2PN1

 NBR/PVC cover comes in gray only.

Current Ratings

Rated Insulation Voltage (Ui)		125V	
Thermal Current (Ith)		3A	
Rated Operating Voltage (Ue)		30V	125V
Rated Operating Current (Ie)	AC	Resistive Load (AC-12)	0.5A
		Inductive Load (AC-15)	0.3A
	DC	Resistive Load (DC-12)	1A
		Inductive Load (DC-13)	0.7A
Contact Configuration (3 Position Switch)		2 contacts (DPDT)	

 Minimum applicable load (reference): 3V AC/DC, 5mA.

Circuit Diagrams

Terminal Arrangement (Bottom View)

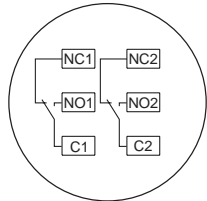

-  1. 3 position switch: 2 contacts, terminal no. = between NO1-C1, between NO2-C2
2. Use between NO-C for OFF→ On→ OFF 3 position switch (NC is not used).

Mounting Hole Layout

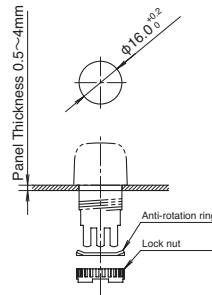

-  1. Recommended tightening torque for Locking Ring: 0.29 to 0.49 N·mm.
2. Use a lock nut tool to screw on the lock nut (see page 415).

Operating Characteristics

Operating Characteristics (without rubber cover/center of button being pushed)

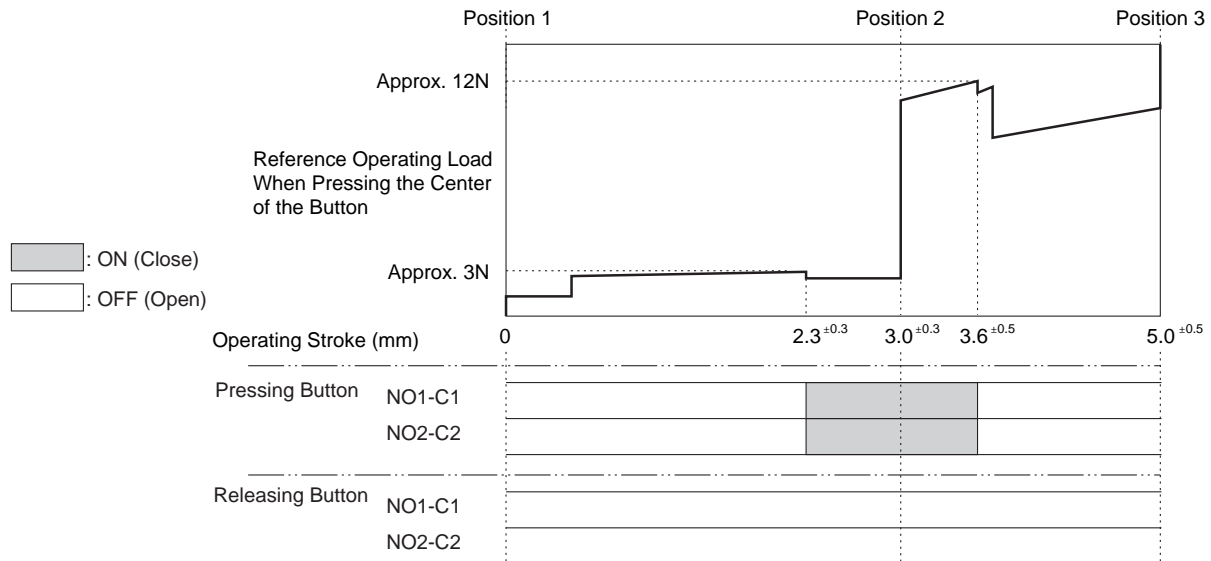

Operating load depends on ambient temperature.

Dimensions (mm)
With Rubber Cover

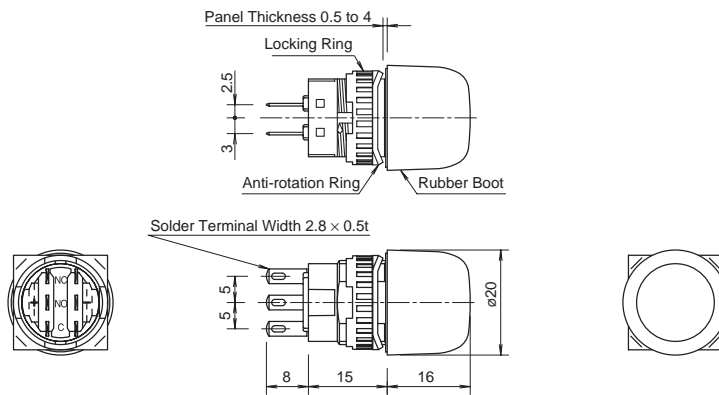

Accessories
Replacement Rubber Cover

Appearance	Part Number	Material
	Silicon Rubber	Yellow HE9Z-D5Y
		Black HE9Z-D5B
	NBR/PVC Polyblend	Gray HE9Z-D5N1

NBR/PVC cover comes in gray only.

Lock Nut Tool

Appearance	Part Number	Material
	MT-001	Metal

Overview

X Series E-Stops

Door Interlock Switches

Enabling Switches

Barriers

AS-Interface Safety at Work

HE1G Series Grip Style Enabling Switch

Overview

X Series E-Stops

HE5B Key features include:

- 3 position functionality (Off – On – Off) as required for manual robotic control
- Ideally suited for use as an enabling (aka “deadman”) switch for robotic cells
- Provides a high level of safety based on human behavioral studies that determine personnel may squeeze OR let go when presented with a panic situation
- Contacts will not re-close when released from Off → On (3 → 1) (per IEC60204-1; 9.2.5.8)
- Optional E-Stop switch built in
- Connection for conduit and cable strain relief built in
- IP66 waterproof sealing
- Meets ANSI RIA 15.06 robotics standards
- Optional momentary pushbutton or E-Stop built in



Direct Opening
Action

Double
Installation

Door Interlock Switches

Enabling Switches

Barriers

AS-Interface Safety at Work

Specifications

Conforming to Standards	IEC60947-5-1, EN60947-5-1, JIS C8201-5-1, UL508, CSA C22.2 No 14	
Applicable Standards	ISO12100/EN292, IEC60204-1/EN60204-1, ISO11161/prEN11161, ISO10218/EN775, ANSI/RIA R15.06,	
Operating Temperature	-25 to +60°C (no freezing)	
Operating Humidity	45 to 85% RH maximum (no condensation)	
Storage Temperature	-40 to +80°C (no freezing)	
Pollution Degree	3	
Contact Resistance	100mΩ maximum	
Insulation Resistance	Between live & dead metal parts: 100MΩ maximum Between positive & negative live parts: 100MΩ minimum	
Impulse Withstand Voltage	2.5kV	
Operating Frequency	1200 operations/hour	
Mechanical Life	Position 1 → 2 → 1: 1,000,000 operations minimum Position 1 → 2 → 3 → 1: 100,000 operations minimum	
Electrical Life	100,000 minimum at rated load	
Shock Resistance	Operating Extremes	100m/s ² (10 G)
	Damage Limits	1000m/s ² (100 G)
Vibration Resistance	Operating Extremes	5 to 55Hz, amplitude 0.5mm minimum
	Damage Limits	16.7Hz, amplitude 1.5mm minimum
Recommend Wire Size	0.14 to 1.5mm ² (24AWG - 16AWG)	
Recommend Cable Size	ø7 to 13mm	
Conduit Size	M20	
Terminal Pulling Strength	20N minimum	
Terminal Screw Torque	0.5 to 0.6Nm	
Degree of Protection	HE1G-21SM: IP66, HE1G-20MB: IP65 HE1G-20ME: IP65, HE1G-21SMB: IP65	
Conditional Short Circuit Current	50A (250V)	
Recommended Short Circuit Protection	250V/10A fast blow fuse (IEC 60127-1)	
Weight	Approx. 250g (HE1G-20ME) Approx. 210g (HE1G-21SM)	

Part Numbers

Part Numbers	3 Position Switch	Monitor Switch	Emergency Stop Pushbutton	Momentary Pushbutton
HE1G-21SM	2 Contacts	Yes (1NC)	No	No
HE1G-20ME	2 Contacts	No	Yes (2NC)	No
HE1G-21SMB	2 Contacts	Yes (1NC)	No	Yes (1NO)
HE1G-20MB	2 Contacts	No	No	Yes (2NO)

Overview

Ratings

Contact Ratings

Rated Insulation Voltage (Ui)		250V				
Thermal Current (Ith)		3A				
Rated Operating Voltage (Ue)		30V	125V	250V		
Rated Operating Current (Ie)	3 Position Switch (Terminal No.1-2, 3-4)	AC	Resistive Load (AC-12)	–	3A	0.5A
			Inductive Load (AC-15)	–	1.5A	0.5A
		DC	Resistive Load (DC-12)	2A	0.4A	–
			Inductive Load (DC-13)	1A	0.22A	–
	Monitor Switch (Terminal No. 5-6 of HE1G-21SM)	AC	Resistive Load (AC-12)	–	2A	1A
			Inductive Load (AC-15)	–	1A	0.5A
		DC	Resistive Load (DC-12)	2A	0.4A	0.2A
			Inductive Load (DC-13)	1A	0.22A	0.1A
	Emergency Stop Pushbutton (Terminal No. 5-6, 7-8 of HE1G-20ME)	AC	Resistive Load (AC-12)	–	–	–
			Inductive Load (AC-15)	–	–	0.5A
		DC	Resistive Load (DC-12)	–	–	–
			Inductive Load (DC-13)	–	–	0.1A
Contact Structure	3 Position Switch		2 Contacts			
	Monitor Switch		0 or 1 Contact			
	Emergency Stop Pushbutton		0 or 2 Contacts			
	Momentary Pushbutton		0 to 2 contacts			

X Series E-Stops

Door Interlock Switches

Enabling Switches

The minimum load (reference) = AC/DC3V • 5mA (for reference only).

Barriers

AS-Interface Safety at Work

Operation Characteristics

Overview

Contact Movement

• **HE1G-21SM**

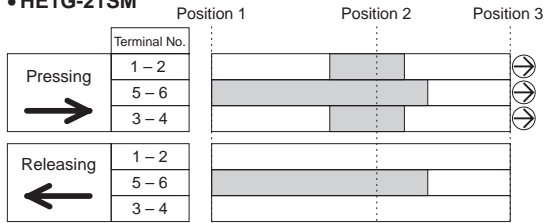

• **HE1G-20ME**

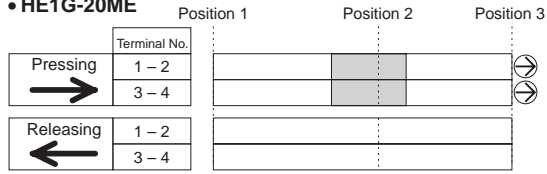

+
Emergency Stop Switch: 2NC contact (terminal No. 5-6, 7-8)

X Series E-Stops

• **HE1G-21SMB**

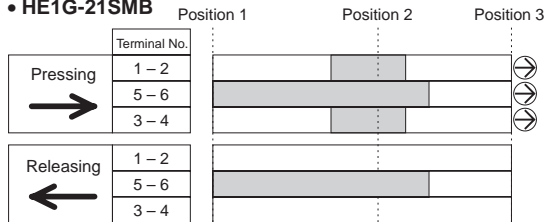

• **HE1G-20MB**

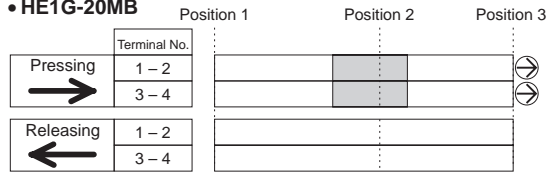

+
Momentary Pushbutton: 2NO contact (terminal No. 5-6, 7-8)

+
Momentary Pushbutton: 1NO contact (terminal No. 7-8)

■ : contact ON (closed) □ : contact OFF (open)

- 1. Terminals No. 1-2, 3-4, 5-6 will become positive action when moving from position 2 to 3.
- 2. Use terminal contacts 1-2 and 3-4 for safest circuit.
- 3. When the center of the button is pressed, the above operation characteristics occur.

Door Interlock Switches

Enabling Switches

Barriers

AS-Interface Safety at Work

HE1G-21SM

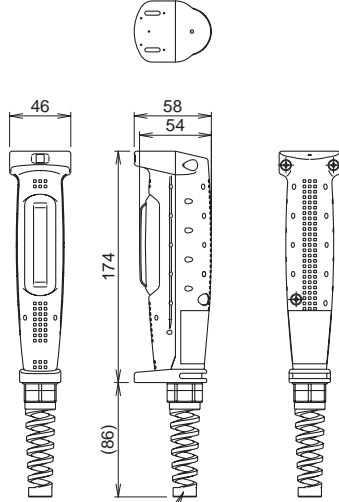

Connector (supplied with grip switch)
Part No. SKINTOP BS-M20x1.5 (LAPP)

Dimensions
HE1G-20ME

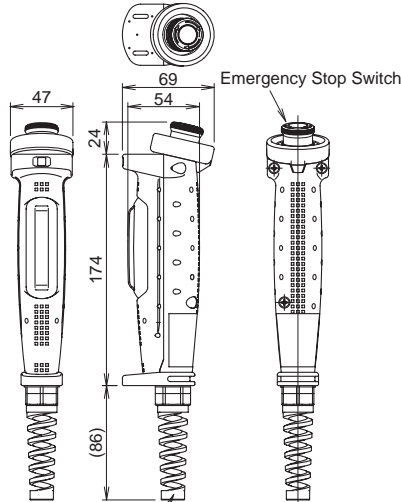

Connector (supplied with grip switch)
Part No. SKINTOP BS-M20x1.5 (LAPP)

HE1G-20MB/21SMB

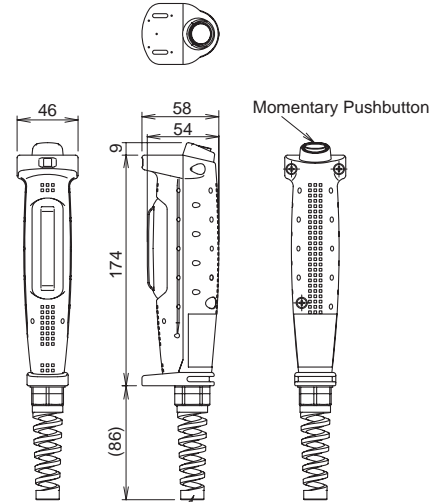

Connector (supplied with grip switch)
Part No. SKINTOP BS-M20x1.5 (LAPP)

Accessories

Replacement Rubber Cover

Appearance	Part Number	Material	Color
	HE9Z-GBK1	Silicon Rubber	Yellow

Mounting Plate (secures grip switch)

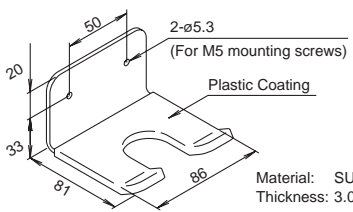
Appearance	Part Number	Material
	HE9Z-GH1	Metal

Material: SUS304
Thickness: 3.0 mm

General Information

Safety Precautions

- In order to avoid electric shock or fire, turn power off before installation, removal, wire connection, maintenance or inspection of switch.
- Follow specification when installing. Improper electrical load may damage switch, cause electric shock, or fire.

- Use proper wire diameter to meet voltage and current requirements. Using improper wires or incomplete soldering may cause fire due to abnormal heat generation.

Installation Precautions

HE2B

- M3 nut is inside the rubber cover.

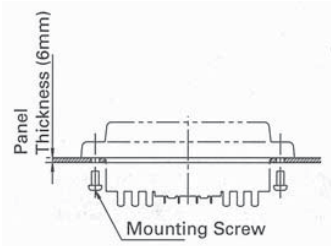

HE2B/HE3B

- A change in internal air pressure may cause the rubber boot to expand and shrink on an enabling switch that has the rubber boot sealed. This may affect the performance of the switch. Periodically check to ensure that the enabling switch is operating correctly.

- If the panel is not level when mounting an enabling switch, the waterproof feature cannot be guaranteed.

HE3B

- The rubber boot has a tab to be used for orientation. When making a positioning hole in a panel, do not make a hole in the rubber boot, or the waterproof feature cannot be guaranteed. When the positioning hole is not on the panel, remove the tab, but do not make a hole in the rubber boot.
- When tightening the locking ring, secure the flange to prevent the enabling switch from rotating. In applications where the enabling switch is to be rotated, mount the switch in a recess on the panel as shown.

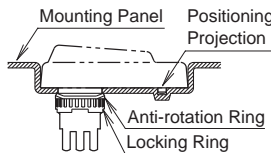

Wiring Precautions

HE1B/HE2B/HE3B

- Applicable wire size is 0.5mm² (20AWG) (maximum) / 1 line.
- When soldering the terminal, solder at a temperature of 260°C within 3 seconds. Use non-corrosive liquid rosin as soldering flux.

- Recommended Torque

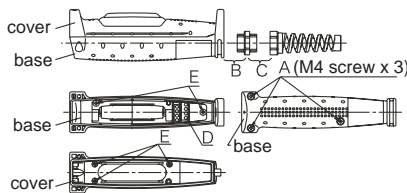

HE1G

- Wire Stripping Information

Wire Length	Terminal Number 1-4	Terminal Number 5-8
L1, L2 (mm)	L1=40mm	L2=27mm
L3 (mm)	L3=6mm	

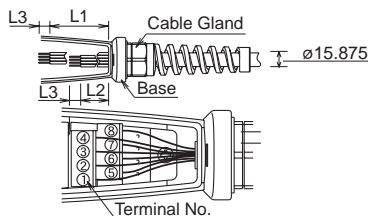

- Applicable Wire Size: 0.14 to 1.5mm² (24 - 16AWG, one wire per terminal)

	See Drawing Above	Recommended Torque
Rubber Boot & Base	A	1.2±0.1Nm
Connector & Grip Switch	B	4.0±0.3Nm
Connector	C	4.0±0.3Nm
Terminal Screw	D	0.5±0.6Nm
Do Not Remove	E	

Use Precautions

HE2B/HE3B/HE1G

- To ensure the highest level of reliability connect both contacts to a monitoring device such as a safety relay.

HE1B/HE2B/HE3B

- When installing the enabling switch ensure that it cannot be accidentally activated. For example, a protrusion from a teaching pendant could cause the enabling switch to be activated by the weight of the teaching pendant.

Overview

X Series E-Stops

Door Interlock Switches

Enabling Switches

Barriers

AS-Interface Safety at Work