

# MotorProtection



TIMING

PROTECTION

CONTROL

# Feature Matrix

FEATURE MATRIX																							
MODEL NUMBER	PHASE LOSS	UNDER VOLTAGE	PHASE SEQUENCE	NOMINAL LINE VOLTAGE PHASE-TO-PHASE 50/60 HZ									ENCLOSURE				RESET		LED INDICATOR	UL Recognized	UL Listed	CSA Certified	
				120	208	220	230	240	380	440	460	480	575	STYLE A	STYLE B	STYLE E	STYLE N	AUTOMATIC					MANUAL
PRA-100-AFA			●		●	●	●	●	●	●	●		●				●		●				
PRA-100-AFN			●		●	●	●	●	●	●	●						●		●				
PRA-100-AFE			●		●	●	●	●	●	●	●					●		●					
SLA-120-AFN	●	●	●	●													●			●			
SLA-120-ALA	●	●	●	●									●				●						
SLA-120-ALE	●	●	●	●												●		●		●	●		
SLA-120-ALER	●	●	●	●												●		●		●	●		
SLA-120-ASA	●	●	●	●									●				●		●		●		
SLA-120-ASB	●	●	●	●										●			●		●				
SLA-208-AFN	●	●	●		●												●		●				
SLA-220-AFN	●	●	●			●											●		●				
SLA-230-ALA	●	●	●				●							●			●		●				
SLA-230-ALE	●	●	●		●	●	●	●									●		●		●		
SLA-230-ALER	●	●	●		●	●	●	●									●		●		●		
SLA-230-ASA	●	●	●		●	●	●	●						●			●		●		●		
SLA-230-ASB	●	●	●		●	●	●	●							●		●		●				
SLA-240-AFN	●	●	●					●									●		●				
SLA-380-ALE	●	●	●						●								●		●		●		
SLA-380-ALER	●	●	●							●							●		●		●		
SLA-380-ASA	●	●	●								●				●		●		●				
SLA-440-AFE	●	●	●							●							●		●		●		
SLA-440-ALE	●	●	●								●	●	●				●		●		●		
SLA-440-ALER	●	●	●									●	●	●			●		●		●		
SLA-440-ASA	●	●	●										●	●	●		●		●				
SLA-460-AFE	●	●	●														●		●		●		
SLA-480-AFE	●	●	●														●		●		●		
SLA-575-AFE	●	●	●														●		●		●		
SLA-575-ALE	●	●	●														●		●		●		
SUA-120-ALA	●	●	●	●										●			●		●		●		
SUA-120-ALAU	●	●	●	●										●			●		●		●		
SUA-230-ALA	●	●	●		●	●	●	●						●			●		●		●		
SUA-230-ALAU	●	●	●		●	●	●	●						●			●		●		●		
SUA-380-ASA	●	●	●						●						●		●		●		●		
SUA-440-ASA	●	●	●							●	●	●			●		●		●		●		

Sold by AA Electric 1-800-237-8274 Lakeland, FL • Lawrenceville, GA • Greensboro, NC • East Rutherford, NJ www.AAelectric.com

## FEATURE MATRIX

MODEL NUMBER	PHASE LOSS	UNDER VOLTAGE	OVER VOLTAGE	PHASE UNBALANCE	PHASE SEQUENCE	ADJUSTABLE DELAY	NOMINAL LINE VOLTAGE PHASE-TO-PHASE 50/60 HZ									STYLE E	RESET		LED INDICATOR	CONTROL VOLTAGE REQUIRED	
							120	208	220	230	240	380	440	460	480		575	AUTOMATIC			MANUAL
PBC-120-ALE	●	●	●				●									●	●		●		
PBC-230-ALE	●	●	●					●	●	●	●					●	●		●		
PBC-400-ALE	●	●	●								●					●	●		●		
PBC-440-ALE	●	●	●									●	●	●		●	●		●		
PBC-480-ALE	●	●	●									●	●	●		●	●		●		
PBC-575-ALE	●	●	●											●		●	●		●		
PBC-120/208-ALE	●	●	●					●								●	●		●		
PBC-220/380-ALE	●	●	●								●					●	●		●		
PBC-277/480-ALE	●	●	●											●		●	●		●		
PBD-120-ALE	●	●	●		●	●	●									●	●		●		
PBD-230-ALE	●	●	●		●	●		●	●	●	●					●	●		●		
PBD-400-ALE	●	●	●		●	●					●					●	●		●		
PBD-440-ALE	●	●	●		●	●						●	●	●		●	●		●		
PBD-480-ALE	●	●	●		●	●						●	●	●		●	●		●		
PBD-575-ALE	●	●	●		●	●								●		●	●		●		
PBE-120-ASE	●	●	●		●	●	●									●	●		●		
PBE-230-ASE	●	●	●		●	●		●	●	●	●					●	●		●		
PBE-400-ASE	●	●	●		●	●					●					●	●		●		
PBE-440-ASE	●	●	●		●	●						●	●	●		●	●		●		
PBE-480-ASE	●	●	●		●	●						●	●	●		●	●		●		
PBE-575-ASE	●	●	●		●	●								●		●	●		●		
PBE-120/208-ASE	●	●	●		●	●		●								●	●		●		
PBE-220/380-ASE	●	●	●		●	●					●					●	●		●		
PBE-277/480-ASE	●	●	●		●	●								●		●	●		●		
SLB-200-ALEA*	●			●	●	●	●	●	●	●						●	●		●	●	
SLB-200-ALER*	●			●	●	●	●	●	●	●						●		●	●	●	
SLB-400-ALEA*	●			●	●	●					●	●	●	●		●	●		●	●	
SLB-400-ALER*	●			●	●	●					●	●	●	●		●		●	●	●	
SLC-120-ALE	●			●			●									●	●		●		
SLC-230-ALE	●			●				●	●	●	●					●	●		●		
SLC-380-ALE	●			●							●					●	●		●		
SLC-440-ALE	●			●								●	●	●		●	●		●		

\*The SLB Series is 60 Hz standard.

# Feature Matrix

## FEATURE MATRIX

MODEL NUMBER	PHASE LOSS	UNDER VOLTAGE	OVER VOLTAGE	PHASE UNBALANCE	FREQUENCY SHIFT	PHASE SEQUENCE	ADJUSTABLE DELAY	NOMINAL LINE VOLTAGE PHASE-TO-PHASE 50/60 HZ							STYLE A (Plug-In)	STYLE E (Surface Mount)	DIN RAIL MOUNT	DIN RAIL/SURFACE MT.	RESET		LED INDICATOR	UL RECOGNIZED	UL LISTED	CSA CERTIFIED	CURRENT: OVER/UNDER/UNBAL.			
								120	208	220	230	240	380	440					460	480						575	AUTOMATIC	MANUAL
								SLD-120-ALE	●	●		●		●					●	●								
SLD-120-ASA	●	●		●		●	●	●							●					●		●						
SLD-230-ALE	●	●		●		●	●		●	●	●					●				●		●						
SLD-230-ASA	●	●		●		●	●		●	●	●				●					●		●						
SLD-380-ALE	●	●		●		●	●					●				●				●		●						
SLD-380-ASA	●	●		●		●	●					●				●				●		●						
SLD-440-ALE	●	●		●		●	●						●			●				●		●						
SLD-440-ASA	●	●		●		●	●						●			●				●		●						
SLE-120-ALE	●	●		●				●								●				●		●						
SLE-230-ALE	●	●		●					●	●	●	●				●				●		●						
SLE-380-ALE	●	●		●									●			●				●		●						
SLE-440-ALE	●	●		●										●		●				●		●						
SLH-120-ALE	●	●				●		●								●				●		●						
SLH-230-ALE	●	●				●			●	●	●	●				●				●		●						
SLH-440-ALE	●	●				●								●		●				●		●						
SLJ-120-ALE	●	●				●	●	●								●				●		●						
SLJ-230-ALE	●	●				●	●		●	●	●	●				●				●		●						
SLJ-380-ALE	●	●				●	●						●			●				●		●						
SLJ-440-ALE	●	●				●	●							●		●				●		●						
SLM-120-ASE	●	●	●	●	●	●	●	●								●				●		●	●	●	●			
SLM-230-ASE	●	●	●	●	●	●	●		●	●	●	●				●				●		●	●	●	●			
SLM-380-ASE	●	●	●	●	●	●	●						●			●				●		●	●	●	●			
SLM-440-ASE	●	●	●	●	●	●	●						●			●				●		●	●	●	●			
SLM-575-ASE	●	●	●	●	●	●	●							●		●				●		●	●	●	●			
SLU-100-ASA	●	●	●	●	●	●	●		●	●	●	●	●		●					●		●	●	●	●			
SLU-100-ASD	●	●	●	●	●	●	●		●	●	●	●	●			●				●		●	●	●	●			
SLU-600-ASTDS	●	●	●	●	●	●	●		●	●	●	●	●	●				●		●		●	●	●	●			
MPA-1000	●	●	●	●	●	●	●		●	●	●	●	●					●		●		●	●	●	●	●		
MPA-1100	●	●	●	●	●	●	●		●	●	●	●	●					●		●		●	●	●	●	●		

Sold by AA Electric 1-800-237-8274 Lakeland, FL • Lawrenceville, GA • Greensboro, NC • East Rutherford, NJ www.AAelectric.com

## FEATURE MATRIX

MODEL NUMBER	UNDER VOLTAGE	OVER VOLTAGE	ADJUSTMENT-KNOB	ADJUSTMENT-LOCKNUT	ADJUSTMENT-FIXED	NOMINAL LINE VOLTAGE										ENCLOSURE			LED INDICATOR	UL RECOGNIZED	CSA CERTIFIED			
						12 VDC	24 VAC	24 VDC	28 VDC	48 VDC	110 VDC	120 VAC	208 VAC	220 VAC	230 VAC	240 VAC	440 VAC	STYLE A				STYLE E	STYLE N	
						UOA-12-D*A	●		●	●	●	●												
UOA-24-A*A	●		●	●	●		●												●				●	●
UOA-24-D*A	●		●	●	●			●											●				●	●
UOA-48-D*A	●		●	●	●				●										●				●	●
UOA-110-D*A	●		●	●	●					●									●				●	●
UOA-120-A*A	●		●	●	●						●								●				●	●
UOA-120-AFN	●				●						●										●		●	●
UOA-208-A*A	●		●	●	●							●							●				●	●
UOA-208-AFN	●				●							●									●		●	●
UOA-220-AFN	●				●								●								●		●	●
UOA-230-AFN	●				●									●							●		●	●
UOA-240-A*A	●		●	●	●										●		●		●				●	●
UOA-240-AFN	●				●											●				●			●	●
VBA-12-D*A	●	●	●	●	●	●													●				●	●
VBA-24-A*A	●	●	●	●	●		●												●				●	●
VBA-24-AFN	●	●			●		●														●		●	●
VBA-24-D*A	●	●	●	●	●			●											●				●	●
VBA-28-D*A	●	●	●	●	●				●										●				●	●
VBA-48-D*A	●	●	●	●	●					●									●				●	●
VBA-110-D*A	●	●	●	●	●						●								●				●	●
VBA-120-A*A	●	●	●	●	●							●							●				●	●
VBA-120-AFN	●	●			●							●									●		●	●
VBA-208-A*A	●	●	●	●	●								●						●				●	●
VBA-208-AFN	●	●			●								●								●		●	●
VBA-220-AFN	●	●			●									●							●		●	●
VBA-230-AFN	●	●			●										●						●		●	●
VBA-240-A*A	●	●	●	●	●											●		●					●	●
VBA-240-AFN	●	●			●												●				●		●	●

Adjustments: F = Fixed, K = Knob, L = Locknut

# SLU-100 Series



SLU-100-ASA    SLU-100-ASD



## Universal Phase Monitor

### ORDERING INFORMATION

MODEL NUMBER	DESCRIPTION
SLU-100-ASA	Universal Phase Monitor
SLU-100-ASD	Din Rail Mount Universal Phase Monitor

### TOP LABELS

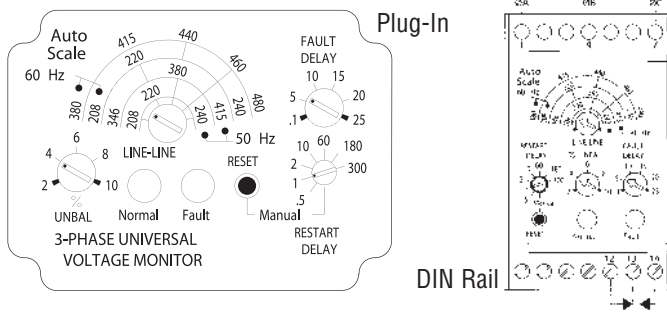

### DIMENSIONS (INCHES)

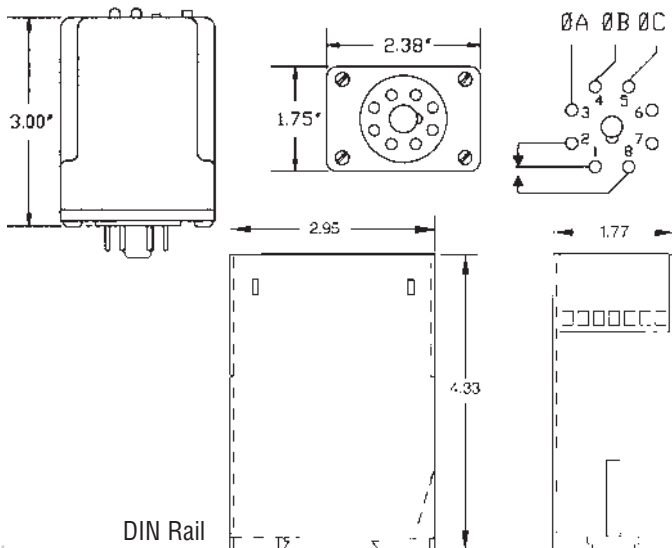

Phase Monitor Relays (3-Phase Monitors) provide cost-effective protection against premature equipment failure caused by voltage faults on 3-Phase systems (Wye or Delta). The SLU Series multi-mode phase monitoring relay, was designed for the convenience of electrician's, maintenance managers and engineers. A single SLU Phase Monitoring Relay can be easily adjusted for the *voltage, imbalance percentage* and time delay requirements to protect against *unbalanced voltages* or *single phasing* regardless of any regenerative voltages.

Both **Delta** and **Wye** systems may be monitored. In Wye systems, connections to neutral are NOT required.

NOTE: Not recommended for generator or variable frequency drive applications. Call technical support for application assistance.

### SPECIFICATIONS

AUTO RANGING SCALES	Frequency	Nominal Line-to-Line Voltages	Adjustable Range
	60Hz	208, 220, 240	200-250
		380, 415, 440, 460, 480	360-500
50Hz	208, 220, 240 346, 380, 415	200-250 330-430	
VOLTAGE BAND	Drop-out	±10% of Range Setting (Under/Over)	
	Pick-up	±7% of Range Setting (Under/Over)	
MAXIMUM VOLTAGE	550 VAC (Line-to-Line)		
PHASE SEQUENCE	ABC (Will Not Operate On CBA Sequence)		
POWER REQUIRED	90VA Max.		
PHASE UNBALANCE	2% to 10%, Adjustable Drop-out		
	Hysteresis	10% of Setting	
PHASE SHIFT	13° Drop-out, 12° Pick-up (Ø-Loss)		
FREQUENCY SHIFT	50/60 Hz		
	Drop-out	± 4%	
Pick up	± 3%		
RESET	Automatic or Manual Mode		
RELAY OUTPUT	SPDT, 10A @ 240VAC Resistive, 1/2 HP @240VAC		
INDICATORS	Flashing	Continuous	
	Normal (Green LED)	Fault Delay Active	Relay Energized
	Fault (Red LED)	Restart Delay Active	Relay De-energized
RESPONSE TIMES	Power Up	2.5 S Minimum	
	Fault Delay	0.1 to 25 S, Adjustable	
	Severe Fault	100mS (Phase-Loss, Unbalance or Phase Reversal)	
Restart	0.5 to 300 S, Adjustable (Auto Reset)		
TEMPERATURE RATINGS	Operate	32° to 131°F (0° to +55°C)	
	Storage	-49° to 185°F (-45° to +85°C)	
REPEAT ACCURACY	1% @ Fixed Condition		
TERMINALS (DIN)	Slotted Screw Terminal Clamps, 12AWG Max.		
ENCLOSURE	Style "A"	LEXAN® Dust Cover	
	DIN	35mm DIN Rail, 14 Term Polycarbonate Housing	
WEIGHT	0.35 to 0.5 lbs.		

The ATC-Diversified Electronics **SLU-600-ASTDS** Universal Phase Monitor protects 3-phase motors up to 700VAC. The **Rapid Cycling** feature prevents motors cycling due to load-induced line fault conditions. Powered by 120VAC, this reliable motor protection relay is unaffected by transients and disturbances from the monitored power source.



Universal Phase Monitor

**SPECIFICATIONS**

AUTO RANGING SCALES	Frequency	Nominal Line-to-Line Voltages		Adjustable Range
	60Hz	208, 220, 240		200-250
		380, 415, 440, 460, 480		360-500
		575, 600		550-630
	50Hz	208, 220, 240		200-250
		346, 380, 415		330-430
3 Ø VOLTAGE BAND	Drop-out	±10% of Range Setting (Under/Over)		
	Pick-up	±7% of Range Setting (Under/Over)		
CONTROL VOLTAGE	120 VAC ±10%, 50/60Hz			
MAXIMUM VOLTAGE	700 VAC (Line-to-Line)			
PHASE SEQUENCE	ABC (Will Not Operate On CBA Sequence)			
POWER REQUIRED	90VA Max.			
PHASE UNBALANCE	2% to 10%, Adjustable Drop-out			
	Hysteresis	10% of Setting		
PHASE SHIFT	13° Drop-out, 12° Pick-up (Ø-Loss)			
FREQUENCY SHIFT	50/60 Hz			
	Drop-out	± 4%		
	Pick up	± 3%		
RAPID CYCLING	5 Cycle Lockout, 30-Min. Cycle Count Reset			
RESET	Automatic or Manual Mode Clears Rapid Cycle Count			
RELAY OUTPUT	DPDT, 10A @ 240 VAC Resistive			
LED'S		Flashing	Continuous	
	Normal (Green LED)	Fault Delay Active	Relay Energized	
	Fault (Red LED)	Restart Delay Active	Relay De-energized	
	Over (Red LED)	Restart Delay Active	Relay De-energized	
	Unbal / Ø Loss (Red LED)	Relay De-energized	Relay De-energized	
RESPONSE TIMES	Power Up	2.5 S Minimum		
	Fault Delay	0.1 to 25 S, Adjustable		
	Severe Fault	100mS (Ø-Loss, Unbalance or Ø Reversal)		
	Restart	0.5 to 300 S, Adjustable (Auto Reset)		
TEMPERATURE RATING	Operate	32° to 131°F (0° to +55°C)		
	Storage	-49° to 185°F (-45° to +85°C)		
REPEAT ACCURACY	1% @ Fixed Condition			
TERMINALS	Plug and Socket Term Block with Spring Pressure Wire Retention, 12 AWG Max.			
ENCLOSURE	35mm DIN Rail or Surface Mount, Polycarbonate Housing			
WEIGHT	1.10 lb.			

- Monitors up to 700 VAC
  - DIN Rail or Surface Mount
  - Operating Range 200-630 VAC
  - Manual or Automatic Reset
  - Adjustable Restart Delay
  - Adjustable Fault Delay
- PROTECTS AGAINST:
- Rapid Cycling
  - Phase Loss
  - Phase Reversal
  - Phase Unbalance
  - Phase Shift
  - Over/Under Voltage
  - Over/Under Frequency

**ORDERING INFORMATION**

MODEL NUMBER	DESCRIPTION
SLU-600-ASTDS	Universal Phase Monitor/Relay

## DIMENSIONS (INCHES/MILLIMETERS)

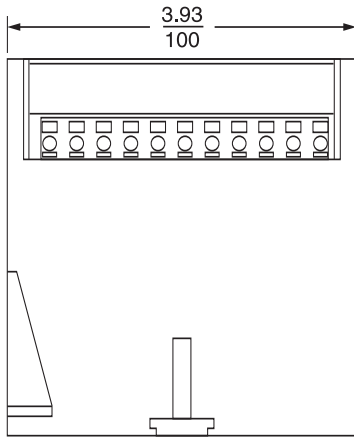
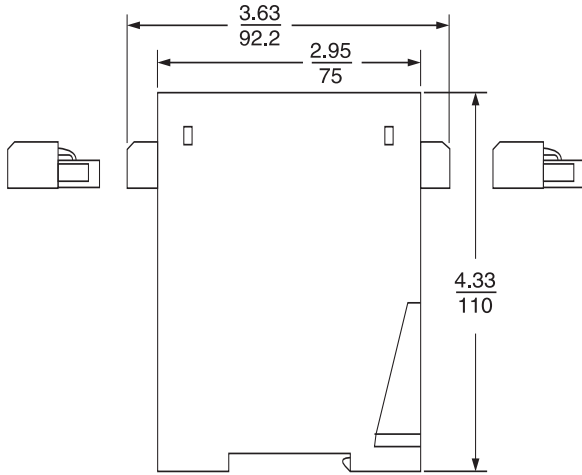

## TOP LABEL

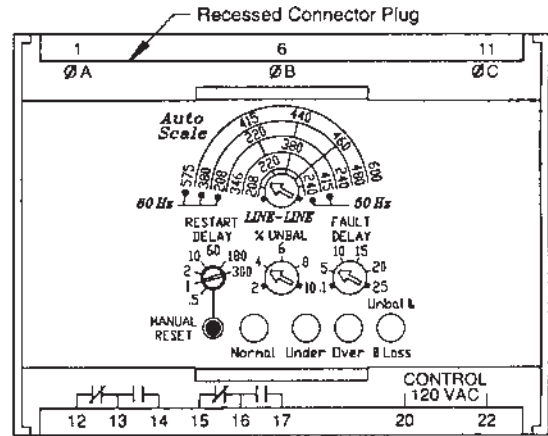

## LED STATUS CHART

- = OFF
- = ON
- ☀ = FLASHING

	Normal Green LED	Under Red LED	Over Red LED	Unbal & Ø Loss Red LED
Powering Up/First 3 Sec	●	●	●	☀
Powered Up/Normal Voltages	○	●	●	●
Relay ON/Under Voltage Detected/FAULT DELAY active	☀	●	●	●
Relay ON/Over Voltage Detected/FAULT DELAY active	☀	●	●	●
Relay ON/Unbal or Ø Loss Detected/FAULT DELAY active	☀	●	●	●
Relay OFF/Under Voltage Failure	●	○	●	●
Relay OFF/Over Voltage Failure	●	●	○	●
Relay OFF/Unbal or Ø Loss Failure	●	●	●	○
Relay OFF/Under Voltage Corrected/RESTART DELAY active	●	☀	●	●
Relay OFF/Over Voltage Corrected/RESTART DELAY active	●	●	☀	●
Relay OFF/Unbal or Ø Loss Corrected/RESTART DELAY active	●	●	●	☀

The **MotorGuardian™** is a microprocessor based overload relay is designed to provide protection for 3-Phase AC motors. It offers a broad range of features in one compact package providing a cost effective solution for monitoring and managing motor performance. Actual motor operating conditions are accessed by the scrolling menu and viewed by a two line highly visible vacuum fluorescent display. Fault conditions are also displayed indicating the specific cause of the occurring fault. A unique feature of the The MotorGuardian™ is its ease of installation. It is provided with Clamp-On C.T.'s that can accommodate up to 1500 ampere loads.

There are two separate models that cover two input voltage ranges. The Model MPA-1000 has a direct input voltage range of 200-500 VAC, 3-phase. The MPA-1100 has been designed to accept secondary volts from medium voltage transformers and has an input range of 120-240VAC, 3-phase.



“MOTORGUARDIAN™”



Motor Performance Analyzer

**DIMENSIONS (INCHES/MILLIMETERS)**

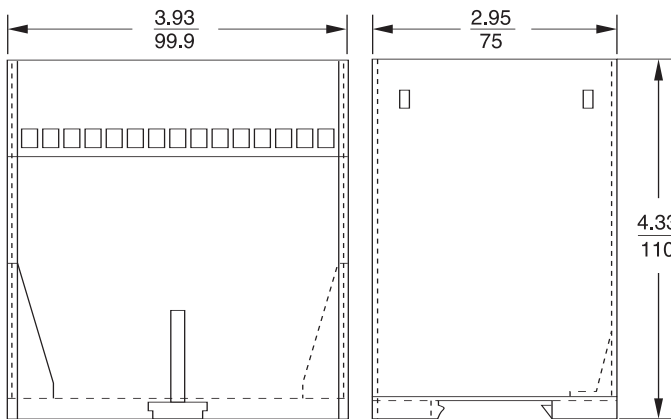

**C.T. ORDERING INFORMATION**

**3 Required, 1 Per Phase**

Order separately using SCT part numbers listed within chart or specify which using Code for MPA Part No. at left of chart.

Code for MPA Part No.	Full Load Amps/Phase	0.75" Opening C.T. Part No.	1.25" Opening C.T. Part No.	2.0" Opening C.T. Part No.	C.T. Program Code (Full Scale Amps.)
01A	1.5 - 15A	SCT-0750-015	-	-	015
02A	15 - 150A	SCT-0750-150	-	-	150
02B	15 - 150A	-	SCT-1250-150	-	150
03B	150 - 600A	-	SCT-1250-600	-	600
03C	150 - 600A	-	-	SCT-2000-600	600
04C	600 - 1500A	-	-	SCT-2000-1500	1500

- Standard (200-500 VAC) & Medium Voltage (VAC) Versions 120-240
- True RMS Monitoring
- Up to 1500 Amp Loads
- 3 External Clamp-On C.T.'s
- 9 Programmable Trip Points
- 9 Programmable Alarm Points
- 2 RTD Lead Compensated Temperature Inputs
- Time Tagged Fault History
- DPDT Output; SPDT Alarm Output
- Bidirectional RS485 output Modbus® RTU Protocol
- Built-in Real-Time Clock
- 2 x 16 Fluorescent Display
- No Control Voltage Required
- All English Programming (Scrolling Menu)
- Setpoint Change Lockout

MODEL NUMBER >>>>>	MPA		
	Voltage		
	200-500 VAC	1000	
	120-240 VAC	1100	
	AMPS		
	1.5-15 A		01
	15-150 A		02
	150-600 A		03
	600-1500 A		04
	C.T. Opening Size		
	0.75" Opening		A
	1.25" Opening		B
	2.0" Opening		C

## SPECIFICATIONS

RELAY ACCURACY	Voltage	±1%
	Current	±1%
	G.F. Current	±10%
	Timing	5% ±1 Second
INPUT VOLTAGE	MPA-1000	200-500 VAC 3-Phase (Nominal)
	MPA-1100	120-240 VAC 3-Phase ±20% (Nominal)
FREQUENCY	50/60 Hz	
PHASE SEQUENCE	ABC (will not operate CBA)	
OUTPUT CONTACT	DPDT; Form "C" 10A per pole max / 16 A Total @ 240 VAC	
ALARM OUTPUT	SPDT; Form "C" 7 A @ 240 VAC	
COMMUNICATION OUTPUT	RS485 Modbus RTU	
BAUDRATE	2400 - 115 200	
PARITY	Even, None	
WEIGHT	42 oz.	
CT WEIGHTS	"A" size CT's	4 oz.
	"B" size CT's	11 oz.
	"C" size CT's	25 oz.
<b>TIMING DELAYS</b>		
RESTART DELAY #1	Rapid Cycle Timer; 0-999 Sec	
RESTART DELAY #2	Cool Down Timer; 0-999 Min., Active after over current or unbalance fault.	
RESTART DELAY #3	Dry Well Recovery; 0-999 Min., Active after under current fault.	
TRIP DELAY #1	Under Current, 0-99 Sec.	
TRIP DELAY #2	Over & Under Voltage, 0-99 Sec.	

## PROGRAMMABLE TRIP/ALARM POINT

(Each setpoint can be disabled)

LOW VOLTAGE	180-450V RMS
HIGH VOLTAGE	220-550V RMS
VOLTAGE UNBALANCE	1-15%
CURRENT UNBALANCE	1-15%
OVER CURRENT	Up to 100% of C.T. Range. Dependent on C.T. Range, FLA, and Trip Class
UNDER CURRENT	Up to 100% of C.T. Range
GROUND FAULT	2 - 13% of CT Range
OVER TEMP. 1	1-250°C 3-wire 100 Platinum Input or 2-wire with jumper
OVER TEMP. 2	1-250°C 3-wire 100 Platinum Input or 2-wire with jumper
OVER CURRENT	NEMA 5, 10, 15, 20, 30;
TRIP CLASS	Jam protection can be enabled for all classes.

## RESTART COUNTER

AUTO RESTART	Number of Restarts, 0 (Manual), 1-8 or 9 (Automatic)
--------------	--

## C.T. SPECIFICATIONS

ACCURACY	1%
TERMINATIONS	(2) 8ft. twisted pair, 22 AWG
MOUNTING	Snap Closing/Opening Feature

## TERMINAL DETAIL

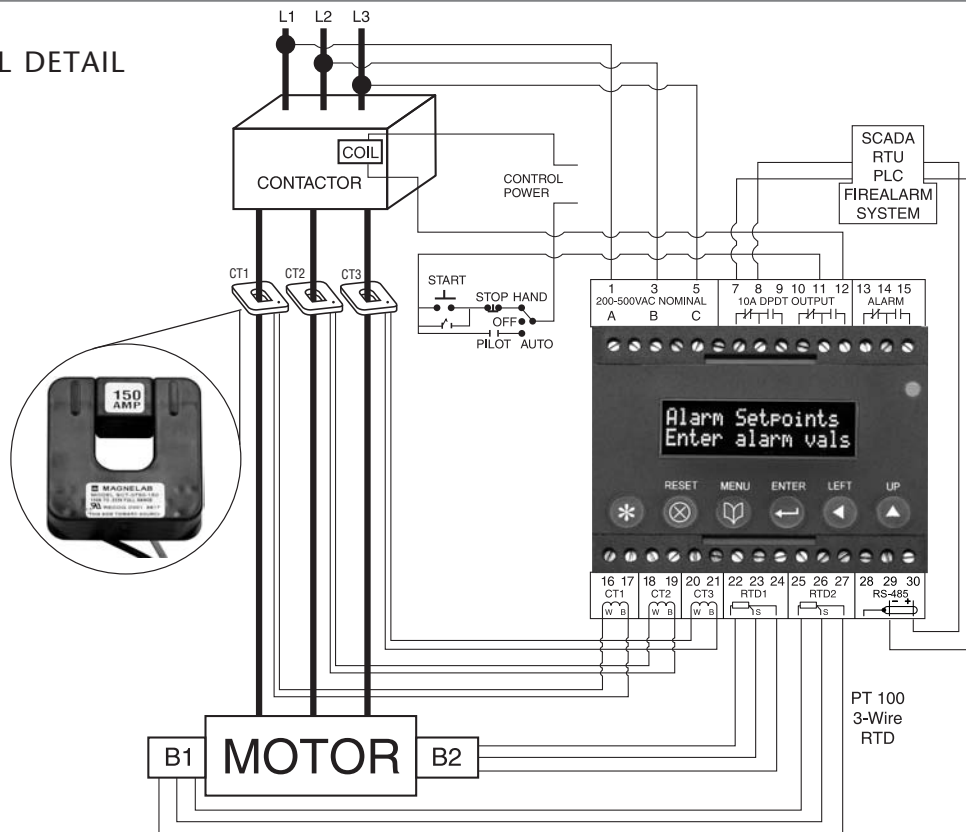

The **MGR Remote Manager** is a component of the **MotorGuardian** family that is used in conjunction with the Motor Performance Analyzer (MPA). It provides full control and monitoring of the MPA functions by mimicking the keypad and display. The front panel programming is identical to the MPA that simplifies the learning process. This external control provides an efficient and safe tool away from potentially dangerous voltages.

The MGR is environmentally protected (NEMA 4X) and is easily mounted using a cutout on the front of a control panel or MCC. A vacuum fluorescent display (VFD) was selected to provide high visibility in both high and low light situations.



MGR Remote Manager

DIMENSIONS (INCHES/MILLIMETERS)

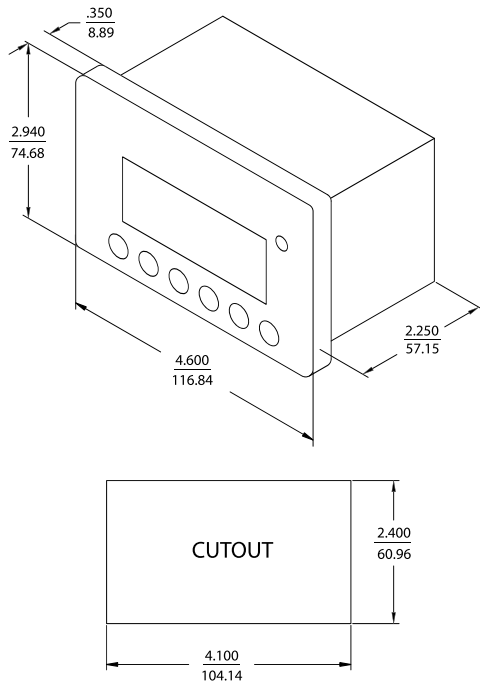

- MPA Remote Monitoring
- Total Control of MPA Functions
- Identical Keypad and Display as MPA-1000 and MPA-1100
- NEMA 4X Protection
- 2 x 16 Vacuum Fluorescent Display
- Polycarbonate Enclosure with Captive Hardware
- Removable Input Terminal Block

SPECIFICATIONS

INPUT VOLTAGE	115/230 VAC ±15% 50-60 Hz Model Selectable	
POWER CONSUMPTION	3 Watts (Max.)	
ENVIRONMENT	-10°C to +55°C NEMA 4X	
COMMUNICATION PORTS	RS485 Modbus RTU	
	Baudrate	2400 to 115200
	Parity	Even, None
WEIGHT	0.9 lbs	

ORDERING INFORMATION

MODEL NUMBER	DESCRIPTION
MGR-1000	MGR Remote Manager

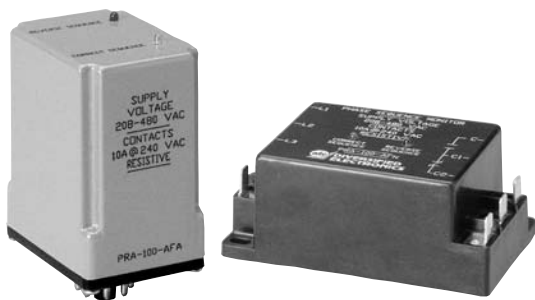

STYLE "A"

STYLE "N"

## Phase Sequence Monitor

### DIMENSIONS (INCHES)

Style "A"

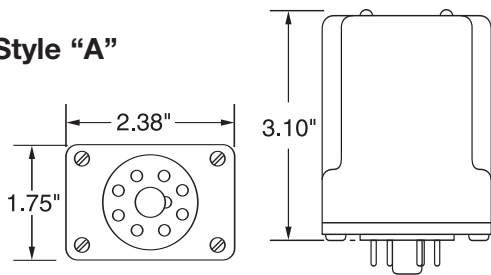

Style "N"

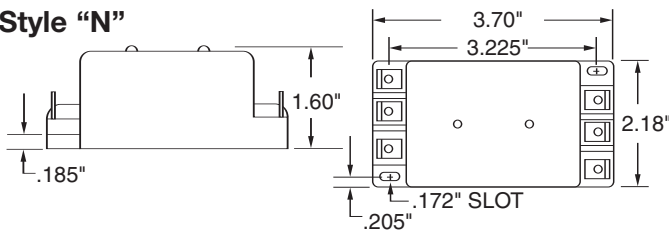

Style "E"

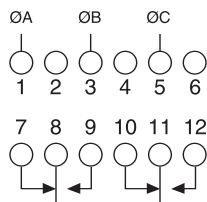
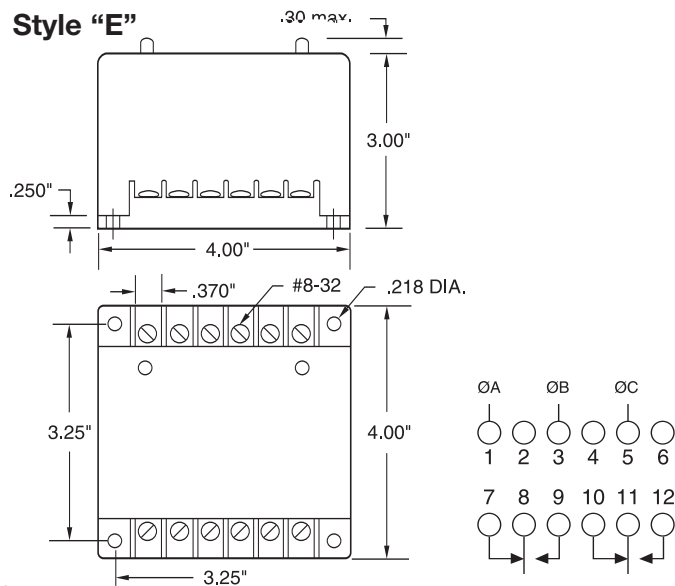

The **PRA-100** Series Phase Sequence Monitors are designed to allow the output to energize *only* when the phase connections are in the proper sequence. For use in applications where *motor direction* is critical or the installation is required by code to have sequence detection.

### OPERATION

When the phase sequence is correct and the operating voltage is present on all phases, the relay will energize and the green LED indicator will glow. If the phases are in reverse rotation, the relay will not energize and the red LED indicator will glow. The PRA-100 Series will not detect phase loss while the motor is turning.

### SPECIFICATIONS

OPERATING VOLTAGE	208-480 VAC ±15%, phase-to-phase, 50/60 Hz	
PHASE SEQUENCE	ABC (Will Not Operate CBA)	
TOTAL APPARENT POWER	11 VA @ 480 VAC	
OUTPUT RATING	Style A & N	SPDT, 10 Amps @ 240 VAC Resistive, 1/2 hp @ 240 VAC
	Style E	DPDT, 10 Amps @ 240 VAC Resistive, 1/2 hp @ 240 VAC
RESET	Automatic	
INDICATORS	Green LED	Glow on correct sequence
	Red LED	Glow on incorrect sequence
RESPONSE TIMES	200 mSEC. (approximately)	
TEMPERATURE RATING	Operate	32° to +131°F (0° to +55°C)
	Storage	-49° to 185°F (-45° to +85°C)
ENCLOSURE	Style "A"	LEXAN® dust cover 8-Pin plug-in. RB-08 or OT-08 Socket
	Style "N"	Glass filled VALOX® surface mounted 6-1/4" male quick connect
	Style "L"	LEXAN® Surface Mount, #8-32 screws
WEIGHT	Style "A"	0.3 lbs.
	Style "N"	0.35 lbs.
	Style "L"	0.75 lbs

MODEL NUMBER >>>>>	PRA	100	
	Enclosures		
LEXAN® dust cover 8-Pin plug-in. RB-08 or OT-08 Socket			AFA
Glass filled VALOX® surface mounted 6-1/4" male quick connect			AFN
LEXAN® Surface Mount, #8-32 screws			AFE

### WIRING

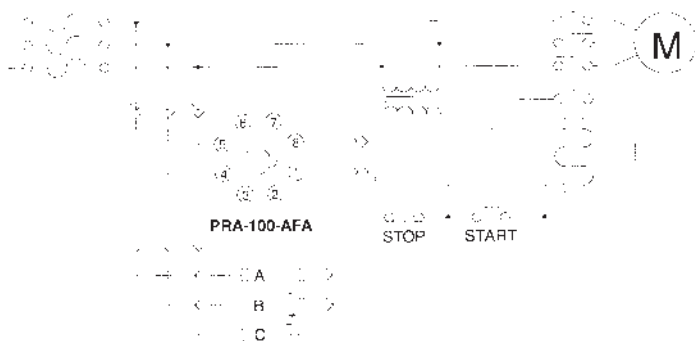

The ATC Diversified SLA Series is designed to protect 3-phase equipment against **PHASE LOSS, UNDER VOLTAGE, and PHASE REVERSAL** conditions.

With normal operating voltages applied in the proper ABC sequence, the internal relay will energize (PICK-UP). When incorrect phase sequence or phase loss occurs or the three-phase voltages fall below the drop out voltages, the relay will de-energize (DROP-OUT). On models featuring indicators, the LED glows when all line conditions are normal.

Both Delta and Wye systems may be monitored. In Wye systems, connections to neutral are NOT required.

For UL Listed units, with field wiring terminals, copper wire with 60°/75°C rating must be used for control circuitry connections.

NOTE: When a phase is lost while the motor is running, a condition known as regeneration occurs where a voltage is induced into the open phase nearly equal in magnitude to the normal phase-to-phase voltage. However, with the exception of lightly loaded motors, enough change is detected by the SLA to provide the required protection when properly adjusted.



Phase Monitors

## SPECIFICATIONS

DROP-OUT VOLTAGE	1 Ø Low	83% of Nominal
	3 Ø Low	90% of Nominal
RESPONSE TIMES STYLE "A" & "E"	<i>Models Up to 300 VAC</i>	
	Operate	250 mSEC
	Release	0.5 SEC
	<i>Models Over 300 VAC</i>	
RESPONSE TIMES STYLE "N"	Operate	1.0 SEC
	Release	2.0 SEC
	Operate	60 mSEC
POWER REQUIRED	Style "E"	<i>Models up to 300 VAC: 3 VA (max.) Models over 300 VAC: 7 VA (max.) Models over 500 VAC: 3 VA (max.)</i>
	Style "N"	3 VA (max.)
	Style "A"	3 VA (approx.)
OPERATING VOLTAGE	See Ordering Information	
RESET	Automatic (Manual Optional)	
INDICATOR LED	Glows when all conditions are Normal <i>(On Applicable Models)</i>	
OUTPUT RATING	SPDT (style "A" and "N") DPDT (style "E")	
PHASE SEQUENCE	ABC (Will Not Operate CBA)	
TEMPERATURE RATING	Operate	32° to +131°F (0° to +55°C)
	Storage	-49° to 185°F (-45° to +85°C)
U.S. PATENT NUMBER	3,611,050	
WEIGHT	Style "A"	NET: 2.24 oz Shipping: 2.56 oz
	Style "E"	NET: 4.8 oz Shipping: 5.76 oz
	Style "N"	NET: 5.3 oz Shipping: 5.6 oz

- Available up to 480 VAC
- Delta or Wye Systems
- Fixed, Lock Shaft, or Screwdriver Adjustment
- Several Enclosure Styles

### TYPICAL APPLICATIONS:

- Air Handlers
- Computer Power Protection
- Conveyor Drive
- Water Waste & Sewage Machinery
- Oil & Gas Pumps
- Sawmill & Woodpump Machinery
- Power Substation

### PROTECTS 3-PHASE EQUIPMENT AGAINST:

- Phase Loss
- Under Voltage
- Phase Reversal

- Automatic Transfer Switching for Monitoring Emergency Power Supplies
- Irrigation Pumps
- Lift Station Pumps
- Robotics Equipment
- Elevator Drives
- Commercial/Industrial Air Conditioning & Refrigeration Compressors

MODEL NUMBER >>>>>>	SLA	A			
Operating Voltage					
See Ordering Information					
Type of Operation					
	Fixed	F			
	Lock Shaft Adjusted	L			
	Screwdriver Adjusted	S			
Enclosure Style					
	Octal Plug-In, Dust Cover	A			
	Blade Plug-In, Dust Cover	B			
	Surface Mounted, #8 Screw Terminals	E			
	Surface Mounted, 1/4" Quick Disconnect Terminals	N			
Options					
	Add R Suffix when manual reset is required, (available only in style "E" enclosure)				R
	Plug-In models are UL listed only when used with RB-08 relay socket.				U

# SLA Series



Style "A"



Style "N"



Style "E"

For UL Listed units, copper wire with 60°/75°C rating must be used for control circuitry connections.

## DIMENSIONS (INCHES)

Style "A"

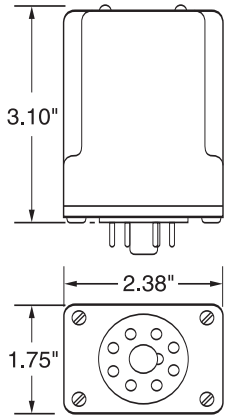

Style "B"

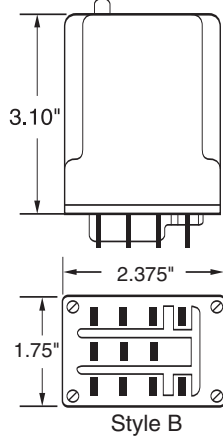

Style "E"

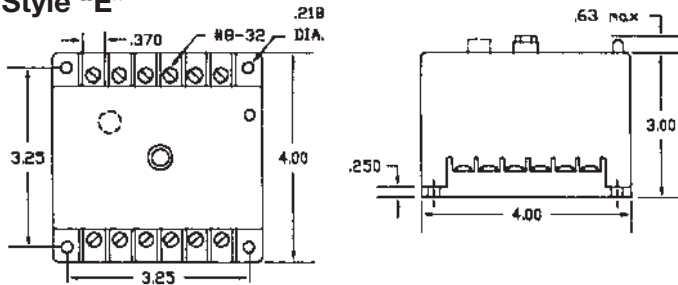

Style "N"

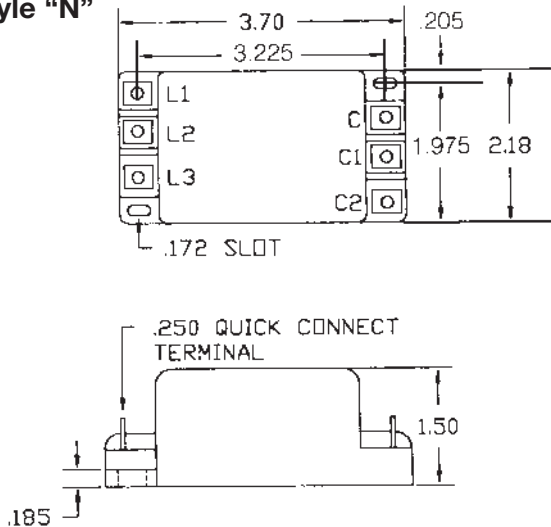

## WIRING

Style "A"

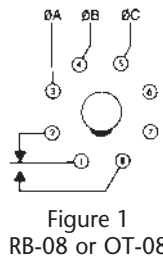

Figure 1  
RB-08 or OT-08

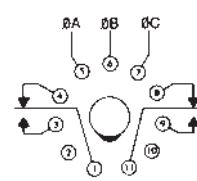

Figure 2  
RB-11

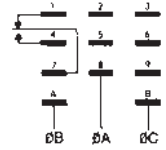

Figure 3  
70-463-1

Style "E"

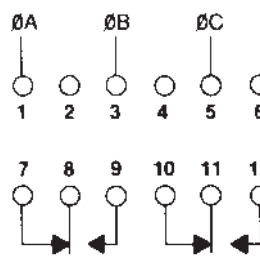

Figure 4

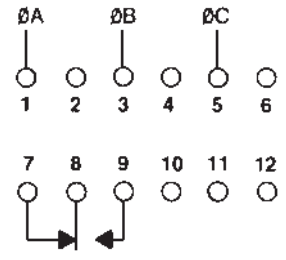
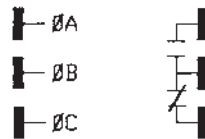

Figure 5

Style "N"



ORDERING INFORMATION

STYLE A PLUG-IN

MODEL NUMBER	OPERATING VOLTAGE	TYPE OF ADJUSTMENT	DROP-OUT VOLTAGE		AGENCY APPROVAL	OUTPUT RATINGS	
			1 Ø LOW	3 Ø LOW			
SLA-120-ALA	95-130 Adj.	Lock Shaft	79-108	85-117	—	DPDT, 345 VA Inductive; 10 Amps Resistive @ 240 VAC, Figure 2	
SLA-120-ASA		Screwdriver			cUL US	cUL US	SPDT, 345 VA Inductive; 10 Amps Resistive @ 240 VAC, Figure 1
SLA-120-ASB							SPDT, 345 VA Inductive; 10 Amps Resistive @ 240 VAC, Figure 3
SLA-230-ALA	190-270 Adj.	Lock Shaft	158-224	171-243	cUL US	DPDT, 345 VA Inductive; 10 Amps Resistive @ 240 VAC, Figure 2	
SLA-230-ASA		Screwdriver			cUL US	cUL US	SPDT, 345 VA Inductive; 10 Amps Resistive @ 240 VAC, Figure 1
SLA-230-ASB							SPDT, 345 VA Inductive; 10 Amps Resistive @ 240 VAC, Figure 3
SLA-380-ASA	350-440 Adj.	Screwdriver	290-365	315-396	—	SPDT, 360 VA Inductive; 10 Amps Resistive @ 240 VAC, Figure 1	
SLA-440-ASA	430-480 Adj.		357-398	387-432			
SUA-120-ALA	95-130 Adj.	Lock Shaft	79-108	85-117	cUL US	SPDT, 345 VA Inductive; 10 Amps Resistive @ 240 VAC, Figure 1	
SUA-120-ALAU*					190-270 Adj.		158-224
SUA-230-ALA	Screwdriver	290-365	315-396	cUL US			
SUA-230-ALAU*				430-480 Adj.	357-398		387-432
SUA-380-ASA	350-440 Adj.	Screwdriver	290-365	315-396	cUL US	SPDT, 360 VA Inductive; 10 Amps Resistive @ 240 VAC, Figure 1	
SUA-440-ASA	430-480 Adj.		357-398	387-432			

\*UL Listed only when used with RB-08 relay socket; 5 Amps Resistive @ 240 VAC. All voltages referenced on this page are phase-to-phase. Models also available with fixed operating voltages. Consult factory.

STYLE E SURFACE MOUNTED ENCLOSURE

MODEL NUMBER	OPERATING VOLTAGE	DROP-OUT VOLTAGE		RESET	AGENCY APPROVAL	OUTPUT RATINGS
		1 Ø LOW	3 Ø LOW			
SLA-120-ALE	95-130 Adj.	79-108	85-117	Automatic	UL LISTED	DPDT, 211 VA Inductive; 10 Amps Resistive @ 120 VAC, Figure 1
SLA-120-ALER				Manual	UL LISTED	DPDT, 211 VA Inductive; 10 Amps Resistive @ 120 VAC, Figure 1
SLA-230-ALE	190-270 Adj.	158-224	171-243	Automatic	UL LISTED	DPDT, 345 VA Inductive; 5 Amps Resistive @ 240 VAC, Figure 1
SLA-230-ALER				Manual	UL LISTED	DPDT, 345 VA Inductive; 5 Amps Resistive @ 240 VAC, Figure 1
SLA-380-ALE	350-440 Adj.	290-365	315-396	Automatic	UL LISTED	DPDT, 360 VA Inductive; 3 Amps Resistive @ 600 VAC, Figure 1
SLA-380-ALER				Manual	UL LISTED	SPDT, 360 VA Inductive; 3 Amps Resistive @ 600 VAC, Figure 2
SLA-440-ALE	430-480 Adj.	357-398	387-432	Automatic	UL LISTED	DPDT, 360 VA Inductive; 3 Amps Resistive @ 600 VAC, Figure 1
SLA-440-ALER				Manual	UL LISTED	SPDT, 360 VA Inductive; 3 Amps Resistive @ 600 VAC, Figure 2
SLA-575-ALE	525-625 Adj.	436-519	473-563	Automatic	UL LISTED	DPDT, 360 VA Inductive; 3 Amps Resistive @ 600 VAC, Figure 1

All voltage referenced are phase-to-phase.—Models also available with fixed operating voltages. Consult factory.

STYLE N EPOXY ENCAPSULATED

MODEL NUMBER	OPERATING VOLTAGE	TYPE OF OPERATION	DROP-OUT VOLTAGE		AGENCY APPROVAL
			1 Ø LOW	3 Ø LOW	
SLA-120-AFN	120	Fixed	100	108	cUL US
SLA-208-AFN	208	Fixed	173	187	
SLA-220-AFN	220	Fixed	183	198	
SLA-240-AFN	240	Fixed	199	216	

All voltage referenced are phase-to-phase.

Sold by AA Electric 1-800-237-8274 Lakeland, FL • Lawrenceville, GA • Greensboro, NC • East Rutherford, NJ www.AA-Electric.com

Phase Voltage Monitors // SLA Series

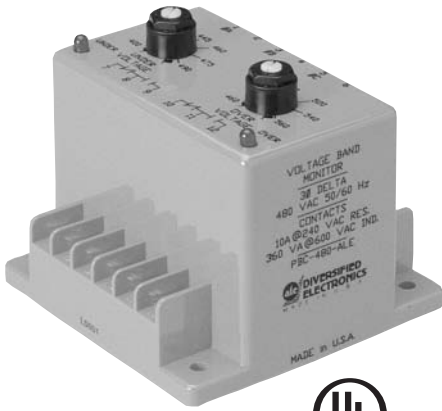

## 3-Phase Voltage Band Monitor

### DIMENSIONS (INCHES)

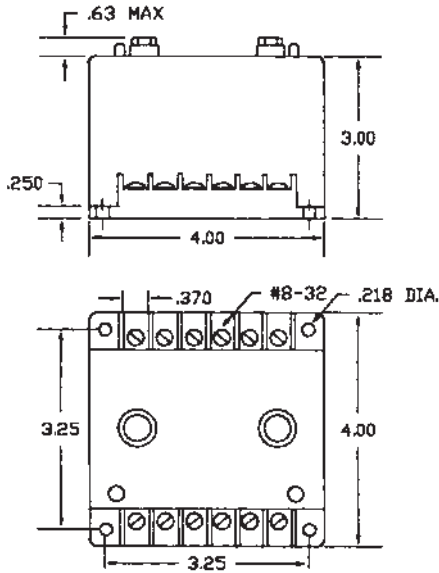

### WIRING

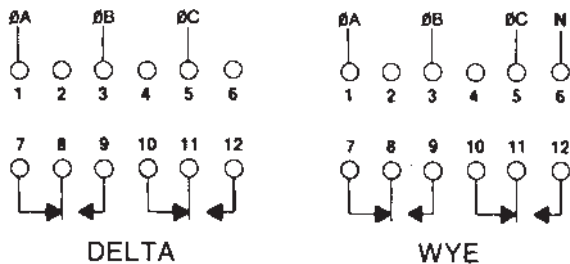

The **PBC Series** offers protection to three-phase equipment that is required to operate between two voltage limits. All three phases are monitored individually for a pre-selected **under** and **over voltage** limit.

### OPERATION

With normal operating voltages applied, the internal relay will energize (PICK-UP). When the voltages on any or all phases fall outside the preset Over/Under trip points for longer than the Release delay, the relay will de-energize (DROP-OUT). When line conditions return to normal, the PBC Series Monitor automatically resets and the internal relay energizes.

The LED fault indicators aid in set up and system trouble-shooting glowing on fault condition. The LED indicators have an immediate response to voltage conditions and operate independently of the relay.

The HYSTERESIS in each unit provides a differential of 4% between the PICK-UP and DROP-OUT trip points.

### SPECIFICATIONS

OUTPUT RATING	DPDT, 3 Amps @ 600 VAC, Resistive; 360 VA @ 600 VAC, Inductive; 1/2 hp	
POWER REQUIRED	Models Up to 300 VAC	7 VA, Max.
	Models Over 300 VAC	6 VA, Max.
RESET	Automatic	
HYSTERESIS	4%	
REPEAT ACCURACY	0.1% @ Fixed Condition	
INDICATORS LED	Glow On Fault; (1) For Over, (1) For Under	
RESPONSE TIMES	Operate	100 mSEC
	Release	0.5 SEC
TEMPERATURE RATING	Operate	32° to +131°F (0° to +55°C)
	Release	-49° to 185°F (-45° to +85°C)
WEIGHT	20 oz.	

### DELTA CONNECTED

MODEL NUMBER	MAXIMUM VOLTAGE	ADJUSTABLE RANGES	
		UNDER	OVER
<b>PBC-120-ALE</b>	155 VAC	90-120	120-150
<b>PBC-230-ALE</b>	275 VAC	185-240	208-265
<b>PBC-400-ALE</b>	485 VAC	325-385	415-475
<b>PBC-440-ALE</b>	550 VAC	390-480	440-540
<b>PBC-480-ALE</b>	570 VAC	400-490	460-560
<b>PBC-575-ALE</b>	700 VAC	500-610	540-690

All voltages referenced on this page are phase-to-phase, unless otherwise indicated.

### WYE CONNECTED

MODEL NUMBER	MAXIMUM VOLTAGE	ADJUSTABLE RANGES Phase to Neutral	
		UNDER	OVER
<b>PBC-120/208-ALE</b>	268 VAC	90-120	120-150
<b>PBC-220/380-ALE</b>	450 VAC	185-220	220-255
<b>PBC-277/480-ALE</b>	565 VAC	235-277	277-320

All voltages referenced on this page are phase-to-phase, unless otherwise indicated.

The **PBD Series** offers protection to three-phase sequence sensitive equipment that is required to operate between two voltage limits. All three phases are monitored individually for a pre-selected Under and Over voltage limit.

**OPERATION**

With normal operating voltages applied in the proper ABC sequence, the internal relay will energize (PICK-UP). When the voltages on any or all phases fall outside the preset Over/Under trip points for longer than the Adjustable Release delay, the relay will de-energize (DROP-OUT). When line conditions return to normal, the PBD Series Monitor automatically resets and the internal relay energizes.

Both Delta and Wye systems may be monitored. In Wye systems, connections to neutral are not required.

The LED fault indicators aid in set up and system troubleshooting, and glow on fault condition. The LED indicators have an immediate response to voltage conditions and operate independently of the relay. In a phase reversal condition the LED responds to voltage conditions but the relay will **NOT** energize.

The **Adjustable Release Delay** is provided to ignore momentary voltage fluctuations that cause nuisance tripping.

The HYSTERESIS in each unit provides a differential of 4% between the PICK-UP and DROP-OUT trip points.

**SPECIFICATIONS**

OUTPUT RATING	DPDT, 3 Amps @ 600 VAC, Resistive; 360 VA @ 600 VAC, Inductive; 1/2 hp	
POWER REQUIRED	Models Up to 300 VAC	7 VA, Max.
	Models Over 300 VAC	6 VA, Max.
RESET	Automatic	
PHASE SEQUENCE	ABC (Will Not Operate CBA)	
HYSTERESIS	4%	
REPEAT ACCURACY	0.1% @ Fixed Condition	
INDICATORS LED	Glow On Fault; (1) For Over, (1) For Under	
RESPONSE TIMES	Operate	100 mSEC
	Release	0.1 to 30 SEC, Adjustable
TEMPERATURE RATING	Operate	32° to +104°F (0° to +40°C)
	Storage	-49° to 185°F (-45° to +85°C)
WEIGHT	19 oz.	

MODEL NUMBER	MAXIMUM VOLTAGE	ADJUSTABLE RANGES	
		UNDER	OVER
<b>PBD-120-ALE</b>	155 VAC	90-120	120-150
<b>PBD-230-ALE</b>	275 VAC	185-240	208-265
<b>PBD-400-ALE</b>	485 VAC	325-385	415-475
<b>PBD-440-ALE</b>	550 VAC	390-480	440-540
<b>PBD-480-ALE</b>	570 VAC	400-490	460-560
<b>PBD-575-ALE</b>	700 VAC	500-610	540-690

All voltages referenced on this page are phase-to-phase.

3-Phase Sequence & Voltage Band Monitor/Relays



**DIMENSIONS (INCHES)**

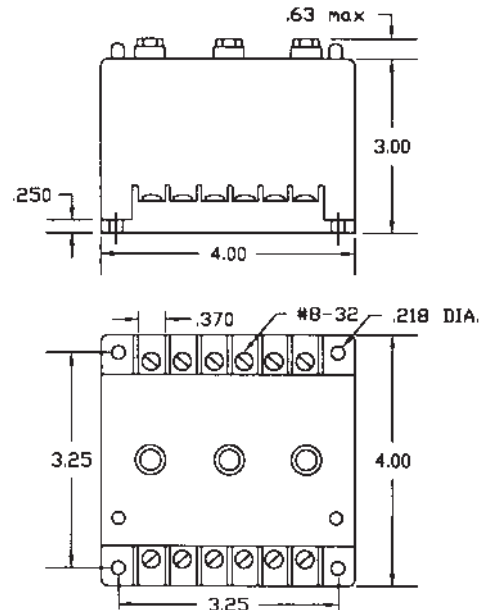

**WIRING**

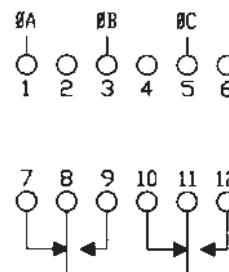

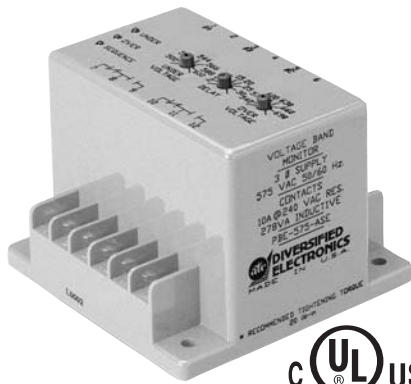

## True RMS Voltage Band Monitor

### DIMENSIONS (INCHES)

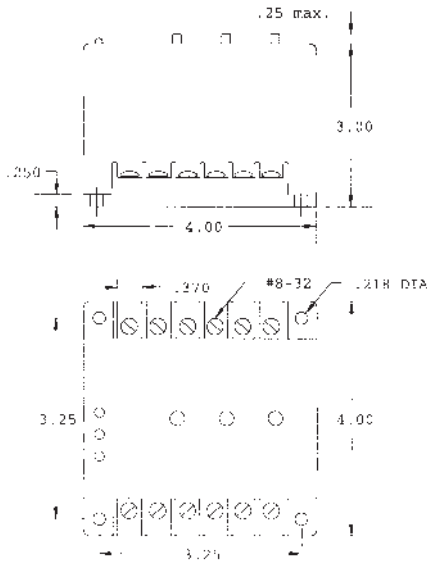

### WIRING

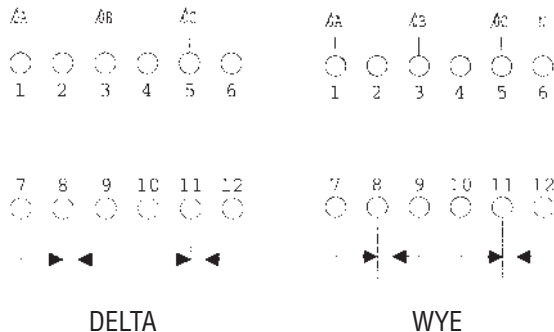

### OPERATION

In today's industrial environment, Line Noise and Power Line Harmonics are becoming an increasing problem. True-RMS detection may be necessary for achieving accurate Line Voltage measurement.

With normal operating voltages applied in the proper ABC sequence, the internal relay will energize (PICK-UP). When the voltages on any or all phases fall outside the preset Over/Under trip points for longer than the Drop-Out Time delay, the relay will de-energize (DROP-OUT). When line conditions return to normal, the PBE Series Monitor automatically resets and the internal relay energizes.

### SPECIFICATIONS

OUTPUT RATING	DPDT, 10 Amps Resistive, 1/4 HP @ 240 VAC	
RESET	Automatic	
PHASE SEQUENCE	ABC (Will Not Operate CBA)	
HYSTERESIS	2%	
REPEAT ACCURACY	0.1% @ Fixed Condition	
INDICATORS LED	Glow On Fault; (1) For Over, (1) For Under, (1) For Sequence	
RESPONSE TIMES	Operate	200 mSEC (approx.)
	Release	0.2 to 30 SEC, Adjustable
TEMPERATURE RATING	Operate	32° to +104°F (0° to +40°C)
	Storage	-49° to 185°F (-45° to +85°C)
ENCLOSURE	Style "E" LEXAN® Surface Mount	
WEIGHT	14 oz.	

### DELTA CONNECTED

MODEL NUMBER	MAXIMUM VOLTAGE	ADJUSTABLE RANGES	
		UNDER	OVER
<b>PBE-120-ALE</b>	155 VAC	90-120	120-150
<b>PBE-230-ALE</b>	275 VAC	185-240	208-265
<b>PBE-400-ALE</b>	485 VAC	325-385	415-475
<b>PBE-440-ALE</b>	550 VAC	390-480	440-540
<b>PBE-480-ALE</b>	570 VAC	400-490	460-560
<b>PBE-575-ALE</b>	700 VAC	500-610	540-690

All voltages referenced on this page are phase-to-phase, unless otherwise indicated.

### WYE CONNECTED

MODEL NUMBER	MAXIMUM VOLTAGE	ADJUSTABLE RANGES Phase to Neutral	
		UNDER	OVER
<b>PBE-120/208-ALE</b>	160 VAC, P to N 277 VAC, P to P	90-120	120-150
<b>PBE-220/380-ALE</b>	260 VAC, P to N 450 VAC, P to P	185-220	220-255
<b>PBE-277/480-ALE</b>	326 VAC, P to N 565 VAC, P to P	235-277	277-320

All voltages referenced on this page are phase-to-phase, unless otherwise indicated.

**OPERATION**

The SLB Series is designed to protect three-phase equipment against **Phase Unbalance, Phase Loss, and Phase Reversal** conditions.

With normal operating voltages in the proper ABC sequence and the 120 VAC control voltage applied, the internal relay will energize (PICK-UP). When any combination of Phase Unbalance exceeding the preset value or Phase Loss or Phase Reversal occurs for longer than the preset drop out time, the output relay will de-energize (DROP-OUT). If the control voltage is removed, the relay will de-energize.

The wide input voltage range permits use on any one of several standard line voltages without recalibrating. The unbalance detection level is adjustable from 2% to 15%.

Both Delta and Wye systems may be monitored. In Wye systems, connections to neutral are not required.

The LED indicator glows when conditions are normal.

NOTE: A balanced condition exists and the output relay will energize when there is a complete absence of voltage on all three phases (Terminals 1, 3 and 5) and the control voltage is continuously applied to (Terminals 11 and 12). For this reason, the SLB series is ideally suited for load side monitoring applications.



Phase Unbalance Monitor

**SPECIFICATIONS**

OUTPUT RATING	SPDT, 10 Amps @ 120 VAC, 5 Amps @ 240 VAC, Resistive	
PHASE SEQUENCE	ABC (Will Not Operate CBA)	
OPERATING VOLTAGE	See Table Below	
CONTROL VOLTAGE	120 VAC, 1 Phase, 60 Hz	
POWER REQUIRED	3 VA, Max.	
PHASE UNBALANCE RANGE	2% to 15%, Adjustable	
INDICATORS LED	Glows When All Conditions Are Normal	
RESPONSE TIMES	Operate	60 mSEC, Fixed
	Release	0.1 to 5 SEC, Adjustable
TEMPERATURE RATING	Operate	32° to +104°F (0° to +40°C)
	Storage	-49° to 185°F (-45° to +85°C)
ENCLOSURE	Style "E" LEXAN® Surface Mount	
WEIGHT	1 lb. 2 oz.	

The SLB Series will not detect an equal and simultaneous reduction in voltage on all three lines (Brown Out).

MODEL NUMBER	OPERATING VOLTAGE	RESET	HYSTERESIS
<b>SLB-200-ALEA</b>	Standard 0-300; 3 Ø Line Voltages 60 Hz	Automatic	10% of Unbalance Setting
<b>SLB-200-ALER</b>		Manual	None
<b>SLB-400-ALEA</b>	Standard 300-500; 3 Ø Line Voltages 60 Hz	Automatic	10% of Unbalance Setting

All voltages referenced on this page are phase-to-phase.

**DIMENSIONS (INCHES)**

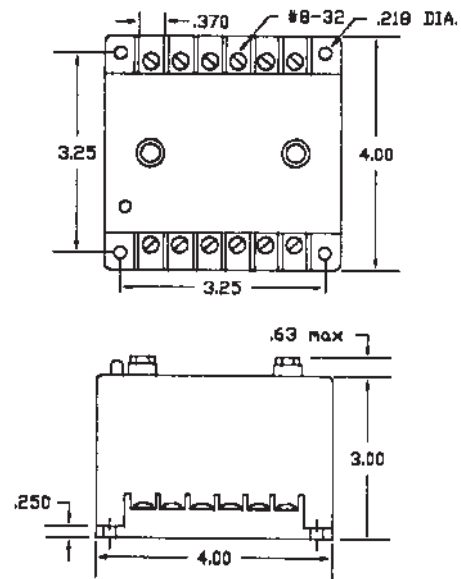

**WIRING**

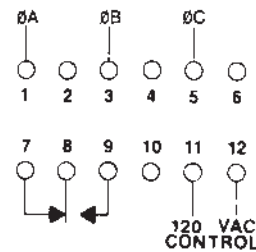



Phase Unbalance & Loss Monitor

The SLC Series is designed to protect 3-phase equipment against **Phase Unbalance** and **Phase Loss** conditions.

### OPERATION

With normal operating voltages applied to all three phases, the internal relay will remain de-energized (DROPPED-OUT).

When a Phase Loss or Phase Unbalance exceeding the pre-selected trip point occurs, the relay will energize (PICK-UP). The SLC series is typically used in conjunction with a shunt trip breaker.

Both Delta and Wye systems may be monitored. In Wye systems, connections to neutral are not required.

**NOTE:** When a phase is lost while the motor is running, a condition known as regeneration occurs where a voltage is induced into the open phase nearly equal in magnitude to the normal phase-to-phase voltage. The SLC series is designed to detect this condition when properly adjusted.

### DIMENSIONS (INCHES)

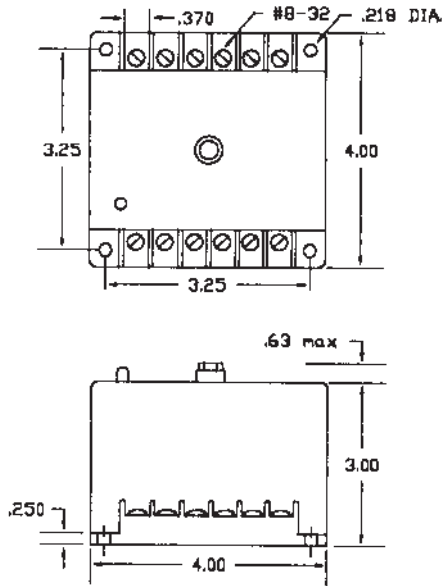

### WIRING

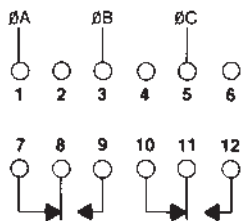

### SPECIFICATIONS

OPERATING VOLTAGE	See Table Below	
TRANSIENT PROTECTION	1000 Volts For 8 mSEC	
RESET	Automatic	
PHASE UNBALANCE RANGE	2% to 10%, Adjustable	
INDICATORS LED	Glows On Fault Condition	
RESPONSE TIMES	Operate	0.08 SEC
	Release	0.7 SEC
TEMPERATURE RATING	Operate	32° to +131°F (0° to +55°C)
	Storage	-49° to 185°F (-45° to +85°C)
U.S. PATENT NUMBER	4,331,995	
WEIGHT	12.5 oz	

MODEL NUMBER	OPERATING VOLTAGE	POWER REQUIRED	OUTPUT RATING
SLC-120-ALE	120 VAC	3 VA Max.	DPDT, 5 Amps, Resistive; 345 VA, Inductive @ 240 VAC
SLC-230-ALE	208/240 VAC		
SLC-380-ALE	380 VAC	7 VA Max.	DPDT, 3 Amps, Resistive; 360 VA, Inductive @ 600 VAC
SLC-440-ALE	440/480 VAC		

All voltages referenced on this page are phase-to-phase.

The SLD Series is designed to protect 3-phase equipment against **Phase Unbalance, Phase Loss, Under Voltage** and **Phase Reversal** conditions.

## OPERATION

With normal operating voltage present on all three phases in the proper phase sequence, the internal relay will energize (PICK-UP). When an incorrect phase sequence or phase loss occurs or the three-phase line voltages fall outside the preset unbalance or under voltage settings, the internal relay will de-energize (DROP-OUT). When all conditions return to normal, the relay will reset.

The **Adjustable Release Delay** is provided to ignore momentary voltage fluctuations that cause nuisance tripping.

Both Delta and Wye systems may be monitored. In Wye Systems, connections to neutral are not required.

NOTE: When a phase is lost while the motor is running, a condition known as regeneration occurs where a voltage is induced into the open phase nearly equal in magnitude to the normal phase-to-phase voltage. The SLD series is designed to detect this condition when properly adjusted.

Style E



Style A

Phase & Under Voltage Monitor

## SPECIFICATIONS

OPERATING VOLTAGE	See Table Below	
TRANSIENT PROTECTION	1000 Volts For 8 mSEC	
RESET	Automatic	
PHASE SEQUENCE	ABC (Will Not Operate CBA)	
PHASE UNBALANCE RANGE	2% to 10%, Adjustable	
INDICATORS LED	Glows When All Conditions Are Normal	
RESPONSE TIMES	Operate	30 mSEC
	Release	0.1 to 20 SEC, Adjustable (on Under Voltage only); 100 mSEC on Phase Reversal and Unbalance
TEMPERATURE RATING	Operate	32° to +131°F (0° to +55°C)
	Storage	-49° to 185°F (-45° to +85°C)
U.S. PATENT NUMBER	4,331,995	
WEIGHT	13.5 oz.	

## DIMENSIONS (INCHES)

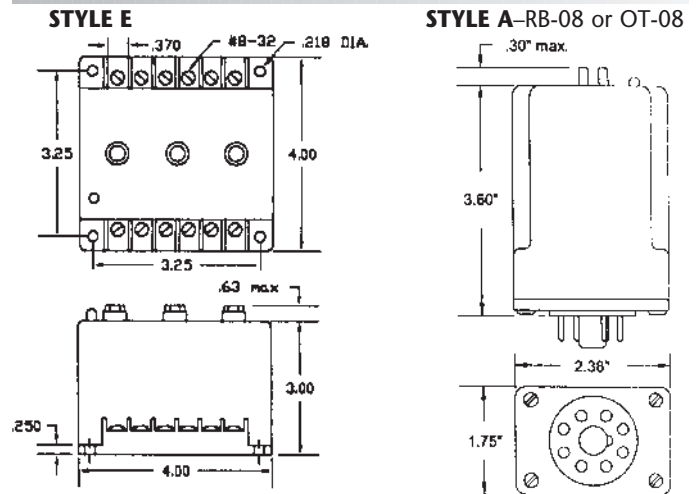

## WIRING

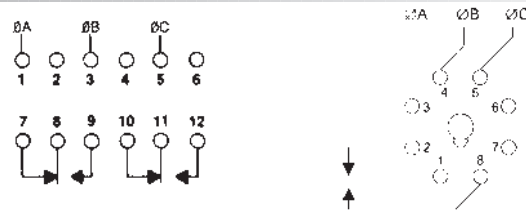

MODEL NUMBER	OPERATING VOLTAGE	UNDER VOLTAGE DROP-OUT RANGE	POWER REQUIRED	HYSTERESIS	OUTPUT RATING	ENCLOSURE
<b>SLD-120-ASA</b>	120 VAC	95-115 Adj.	3 VA Max.	2.5 VAC	SPDT, 10 Amp, Resistive @ 240 VAC 1/2 Hp @ 240 VAC	A
<b>SLD-230-ASA</b>	208/240 VAC	185-230 Adj.		5.0 VAC		
<b>SLD-380-ASA</b>	380 VAC	315-390 Adj.		10 VAC		
<b>SLD-440-ASA</b>	440/480 VAC	370-460 Adj.				
<b>SLD-120-ALE</b>	120 VAC	95-115 Adj.	7 VA Max.	5 VAC	DPDT, 5 Amps, Resistive; 345 VA, Inductive @ 240 VAC	E
<b>SLD-230-ALE</b>	208/240 VAC	185-230 Adj.		10 VAC		
<b>SLD-380-ALE</b>	380 VAC	315-390 Adj.				
<b>SLD-440-ALE</b>	440/480 VAC	370-460 Adj.				

All voltage referenced are phase-to-phase.



## Phase Monitor

- Models Available up to 480 VAC
- PROTECTS 3-PHASE EQUIPMENT AGAINST:
  - Phase Loss
  - Under Voltage
  - Phase Unbalance
- LOCK SHAFT ADJUSTMENT FOR:
  - Phase Unbalanced Percent
  - Under Voltage Drop Out
  - Automatic Reset
  - Delta or Wye Systems

### DIMENSIONS (INCHES)

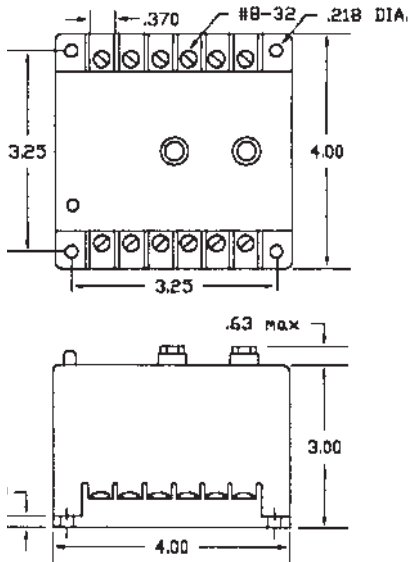

The SLE Series is designed to protect 3-phase equipment against **Phase Unbalance, Phase Loss, and Under Voltage.**

### OPERATION

With normal operating voltage present on all three phases, the internal relay will energize (PICK-UP). When a phase loss occurs or the voltages fall outside the preset unbalance or under voltage settings, the internal relay will de-energize (DROP-OUT). The relay automatically resets when the line conditions return to normal.

Both Delta and Wye systems may be monitored. In Wye Systems, connections to neutral are not required.

NOTE: When a phase is lost while the motor is running, a condition known as regeneration occurs where a voltage is induced into the open phase nearly equal in magnitude to the normal phase-to-phase voltage. The SLE series is designed to detect this condition when properly adjusted.

### SPECIFICATIONS

OPERATING VOLTAGE	See Table Below	
TRANSIENT PROTECTION	1000 Volts For 8 mSEC	
RESET	Automatic	
PHASE UNBALANCE RANGE	2% to 10%, Adjustable	
INDICATORS LED	Glowes When All Conditions Are Normal	
RESPONSE TIMES	Operate	30 mSEC
	Release	0.1 to 20 SEC, Adjustable (on Under Voltage only); 100 mSEC on Phase Reversal and Unbalance
TEMPERATURE RATING	Operate	32° to +131°F (0° to +55°C)
	Storage	-49° to 185°F (-45° to +85°C)
U.S. PATENT NUMBER	4,331,995	
WEIGHT	12.5 to 13 oz.	

### WIRING

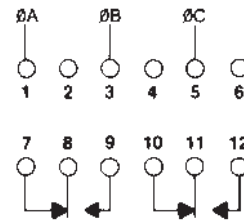

MODEL NUMBER	OPERATING VOLTAGE	UNDER VOLTAGE DROP-OUT RANGE	POWER REQUIRED	HYSTERESIS	OUTPUT RATING
SLE-120-ALE	120 VAC	95-115 Adj.	3 VA Max.	5 VAC	DPDT, 5 Amps, Resistive; 345 VA, Inductive @ 240 VAC
SLE-230-ALE	208/240 VAC	185-230 Adj.			
SLE-380-ALE	380 VAC	315-390 Adj.	7 VA Max.	10 VAC	DPDT, 3 Amps, Resistive; 360 VA, Inductive @ 600 VAC
SLE-440-ALE	440/480 VAC	370-460 Adj.			

All voltage referenced are phase-to-phase.

The SLH Series is designed to protect equipment against **PHASE LOSS** (single phasing), **UNDER VOLTAGE** (brown outs), and **PHASE REVERSAL** (improper sequence).

**OPERATION**

When correct phase sequence and line voltage are present, the internal relay of the SLH will energize (PICK UP). When there is a phase loss, under voltage or phase reversal condition, the internal relay will de-energize (DROP-OUT). When conditions return to normal, the SLH will automatically reset.

The SLH is unique in that it has a **field-adjustable hysteresis**. The voltage setting is adjusted to the desired pick-up point indicated by the dial setting. Then, the hysteresis adjustment is set to the desired percentage to achieve the preferred drop-out point. When models up to 300 VAC are set at 0%, they will pick-up and drop-out at the same point, when set at 10%, the drop-out will be an average of the phase-to-phase voltages 10% below the dial setting pick-up point. Models over 300 VAC are adjustable from 0% to 15%.

The SLH is available in the standard voltage ranges (see table below). It has an LED indicator that glows when all conditions are normal. *The SLH Series is UL Listed under UL File Number E55826.*

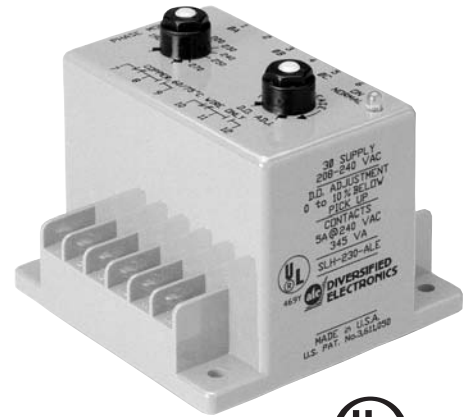

Phase, Under Voltage Monitor with Adj. Hysteresis

**SPECIFICATIONS**

OPERATING VOLTAGE	See Table Below	
POWER REQUIRED	See Table Below	
RESET	Automatic	
PHASE SEQUENCE	ABC (Will Not Operate CBA)	
HYSTERESIS	Models Up to 300 VAC	Adjustable, 0% to 10% Below Pick-up
	Models Over 300 VAC	Adjustable, 0% to 15% Below Pick-up
OUTPUT RATING	Models up to 300 VAC	DPDT, 10 Amps @ 120 VAC, Resistive; 211 VA @ 120 VAC, Inductive
	Models Over 300 VAC	DPDT, 5 Amps @ 240 VAC, Resistive; 345 VA @ 240 VAC, Inductive
TERMINATIONS	(12) #8-32 Screw Terminals	
INDICATORS LED	Glows When All Conditions Are Normal	
RESPONSE TIMES	See Table Below	
TEMPERATURE RATING	Operate	32° to +131°F (0° to +55°C)
	Storage	-49° to 185°F (-45° to +85°C)
WEIGHT	14 oz.	

**DIMENSIONS (INCHES)**

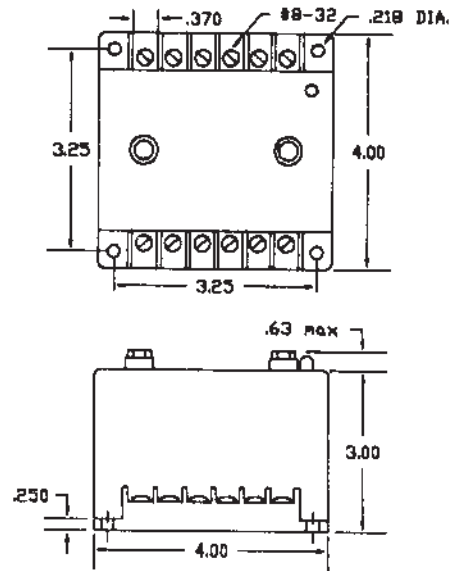

**WIRING**

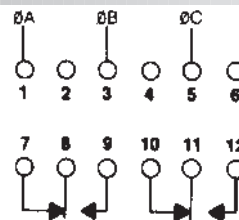

MODEL NUMBER	PICK UP VOLTAGE	RESPONSE TIMES		POWER REQUIRED
		OPERATE	RELEASE	
<b>SLH-120-ALE</b>	95-130 V. Adj.	80 m. SEC	0.5 SEC	3 VA
<b>SLH-230-ALE</b>	190-270 V. Adj.	150 m. SEC	0.5 SEC	3 VA
<b>SLH-440-ALE</b>	430-480 V. Adj.	1.0 SEC	2.0 SEC	7 VA

All voltage referenced are phase-to-phase.



INCLUDES A DELAY-ON-MAKE TIMER

## Phase & Under Voltage Monitor

The SLJ Series has a built-in **Delay-on-Make Time Delay**. The SLJ continuously monitors the three phase lines for adverse conditions such as **PHASE LOSS** (single phasing), **UNDER VOLTAGE** (brown outs), and **PHASE REVERSAL** (improper sequence). When any of these conditions occur, the internal relay will de-energize (DROP-OUT). When the fault is corrected, the field adjustable delay-on-make delay begins. Upon completion of the time delay, the internal relay will energize (PICK-UP). Any subsequent interruptions will reset the delay period.

The SLJ's phase monitor operates the same as the SLA Series. It will drop-out for a phase loss if any phase drops below 83% of its nominal setting and it will also drop-out for under voltage if all three phases drop below 90% of its nominal setting. It is phase sequence sensitive and will not allow start-up if the three phases are reversed.

The SLJ is available in the same standard operating voltage ranges as our other Phase Monitors (see table below). The delay-on-Make Timer is field adjustable from 0.2 to 8.0 minutes.

There are two LED indicators. The green indicator glows when all conditions are normal, and the red indicator glows when the internal relay is energized.

The SLJ is ideally suited for multiple equipment installations to stagger start equipment after a fault condition.

### DIMENSIONS (INCHES)

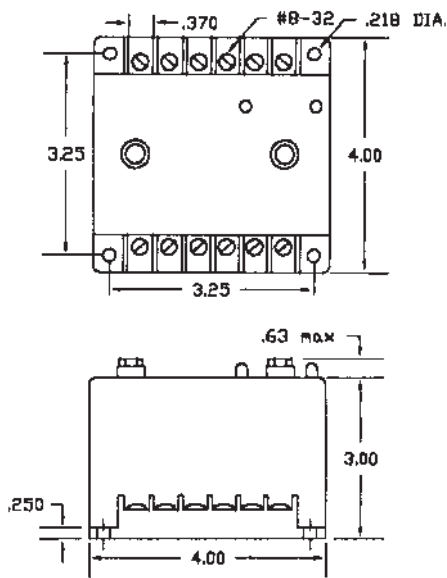

### SPECIFICATIONS

OPERATING VOLTAGE	See Table Below	
OUTPUT RATING	See Table Below	
INDICATORS LED	Green LED	Glow When All Conditions Are Normal
	Red LED	Glow When Relay is Energized
RESPONSE TIMES	Operate	0.2 to 8.0 Minutes, Adjustable
	Release	See Table Below
TEMPERATURE RATING	Operate	32° to +131°F (0° to +55°C)
	Storage	-49° to 185°F (-45° to +85°C)
ENCLOSURE	Style "E" Lexan, Surface Mounted	
TERMINATIONS	(12) #8-32 Screw Terminals	
WEIGHT	14 oz.	

### WIRING

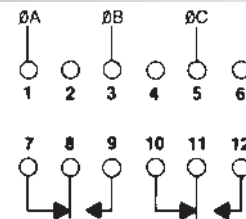

MODEL NUMBER	OPERATING VOLTAGE	DROP-OUT		PICK-UP	DELAY-ON RELEASE	OUTPUT RATING
		1 Ø LOW	3 Ø LOW			
<b>SLJ-120-ALE</b>	95-130 V. Adj.	79-108 V	85-117 V	1 Volt Above Drop-out	0.5 SEC	DPDT, 345 VA Inductive; 10 Amps Resistive @ 240 VAC
<b>SLJ-230-ALE</b>	190-270 V. Adj.	158-224 V	171-243 V			
<b>SLJ-380-ALE</b>	350-440 V. Adj.	290-365 V	315-396 V		2.0 SEC	DPDT, 360 VA Inductive; 3 Amps Resistive @ 600 VAC
<b>SLJ-440-ALE</b>	430-480 V. Adj.	357-398 V	387-432 V			

All voltage referenced are phase-to-phase.

- Models available up to 690 VAC
  - Automatic or Manual Reset
  - Delay-on-Make Timer
  - LED Indicators for Fault Conditions
  - Last Fault Memory
- SCREWDRIVER ADJUSTMENT FOR:
- Time Delay
  - Voltage
  - Mode of Operation
- PROTECTS 3-PHASE EQUIPMENT AGAINST:
- Under Voltage
  - Over Voltage
  - Phase Loss
  - Phase Reversal
  - Phase Unbalance
  - Phase Shift
  - Frequency Shift

**SPECIFICATIONS**

VOLTAGE TRIP POINTS	Drop-Out	±10% of Setting
	Pick-Up	± 7% of Setting
FREQUENCY TRIP POINTS	Drop-Out	±4% of 60 Hz (380 V, 50 Hz)
	Pick-Up	±3% of 60 Hz (380 V, 50 Hz)
UNBALANCE TRIP POINTS	Drop-Out	7%
	Pick-Up	5%
RESET	Automatic; Manual; Automatic with Memory*	
PHASE SEQUENCE	ABC (Will Not Operate CBA)	
OUTPUT RATING	DPDT, 360 VA Inductive; 1/2 hp 3 A Resistive @ 600 VAC	
TERMINATIONS	#8-32 Screw Terminals	

INDICATORS LED*	Designation	Color	State	Condition
	*Automatic with Memory MODE: The last fault is indicated and remains on when conditions return to normal. The indicator extinguishes only with reset or when new fault condition occurs.	Time Delay/Normal	Green	Flashing ON
Under Voltage		Red	ON	Fault
Over Voltage		Red	ON	Fault
Phase Sequence, Shift		Red	ON	Fault
Frequency Shift		Red	ON	Fault
Unbalance		Red	ON	Fault

RESPONSE TIMES	Operate		
	Sampling	2 SEC	
Delay-on-Make	(Sampling Delay) + (1.5 seconds to 5 minute Delay) Adjustable in one (1) minute increments		
RESPONSE TIMES	Release		
	Under Voltage	1.5 SEC, (approx.)	
	Over Voltage	1.5 SEC, (approx.)	
	Frequency Shift	1.5 SEC, (approx.)	
	Unbalance	2.0 SEC, (approx.)	
	*Phase Loss/Shift	1.0 SEC, (approx.)	
	TEMPERATURE RATING	Operate	32° to +131°F (0° to +55°C)
	Storage	-49° to 185°F (-45° to +85°C)	
POWER REQUIRED	7 VA Typical		
TRANSIENT PROTECTION	2500 Volts for 10 ms		
ENCLOSURE	Lexan Surface Mounted		
WEIGHT	22 oz.		

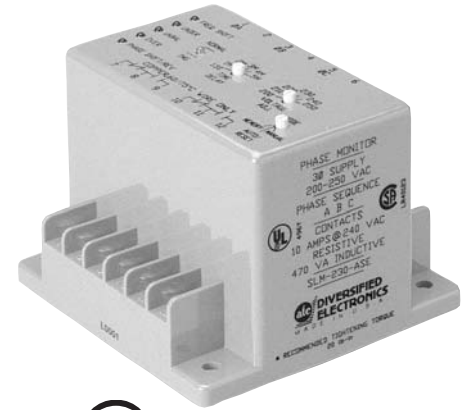

Microprocessor Based 3-Phase Monitor

**DIMENSIONS (INCHES)**

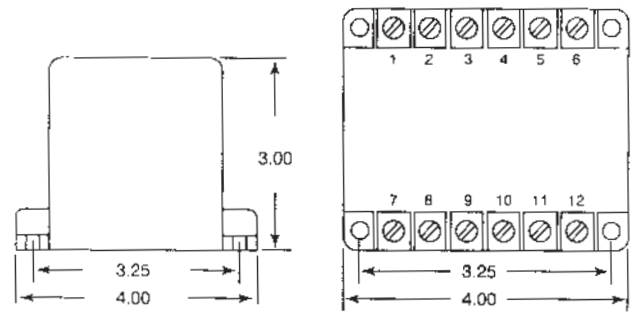

**WIRING**

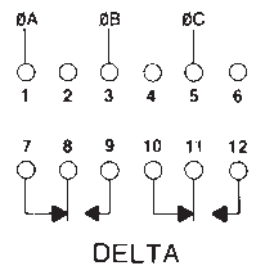

MODEL NUMBER	NOMINAL PHASE-TO-PHASE VOLTAGE SET POINTS	MAXIMUM VOLTAGE
<b>SLM-120-ASE</b>	105, 110, 115, 120, 125, 130	143 VAC
<b>SLM-230-ASE</b>	200, 210, 220, 230, 240, 250	275 VAC
<b>SLM-380-ASE</b>	350, 365, 380, 390, 400, 415	457 VAC
<b>SLM-440-ASE</b>	440, 450, 460, 470, 480, 490	540 VAC
<b>SLM-575-ASE</b>	525, 550, 575, 600	690 VAC

\*Automatic with Memory MODE: The last fault is indicated and remains on when conditions return to normal. The indicator extinguishes only with reset or when new fault condition occurs.

# UOA Series



STYLE A



Style A Only



STYLE N



Single Phase Under Voltage Monitor

The UOA Series offers protection to **single phase** equipment that is required to operate above a certain voltage minimum.

## OPERATION

With operating voltage applied above the preset PICK-UP voltage, the internal relay will energize. When the voltage falls below the preset DROP-OUT voltage for a period longer than the release delay, the output relay will de-energize. When line conditions return above the preset PICK-UP voltage, the UOA Series automatically resets and the internal relay energizes.

The HYSTERESIS in each unit provides a differential between the PICK-UP and DROP-OUT trip points.

## SPECIFICATIONS

OUTPUT RATING	Style A	DPDT, 5A @ 240 VAC, Resistive; 211 VA @ 240, Inductive.
	Style N	SPDT, 10A @ 240 VAC, Resistive; 180 VA, Inductive.
RESPONSE TIMES	Operate	50 mSEC. (approx.) (500 mSEC. on 12 VDC units)
	Release	0.5 SEC (approx.)
TEMPERATURE RATING	Operate	32° to +131°F (0° to +55°C)
	Storage	-49° to 185°F (-45° to +85°C)
POWER REQUIRED	Models Up To 110 VDC:	3 Watts, Max.
	Models Up To 300 VAC:	5 VA, Max.
WEIGHT	5 oz. to 5.5 oz.	

MODEL NUMBER	DROP-OUT VOLTAGE	PICK-UP VOLTAGE	HYSTERESIS VOLTAGE
<b>UOA-24-A*A</b>	19-27 VAC	21-29 VAC	2
<b>UOA-120-A*A</b>	97-130 VAC	102-135 VAC	5
<b>UOA-208-A*A</b>	177-222 VAC	185-230 VAC	8
<b>UOA-240-A*A</b>	205-250 VAC	215-260 VAC	10
<b>UOA-12-D*A</b>	9-14 VDC	10-15 VDC	1
<b>UOA-24-D*A</b>	19-27 VDC	21-29 VDC	2
<b>UOA-48-D*A</b>	38-53 VDC	40-55 VDC	2
<b>UOA-110-D*A</b>	92-125 VDC	97-130 VDC	5
<b>UOA-220-D*A</b>	185-230 VDC	194-239 VDC	9
<b>UOA-240-D*A</b>	205-250 VDC	215-260 VDC	10
<b>UOA-120-AFN</b>	100 VAC	105 VAC	5
<b>UOA-208-AFN</b>	180 VAC	188 VAC	8
<b>UOA-220-AFN</b>	180 VAC	187 VAC	7
<b>UOA-230-AFN</b>	190 VAC	198 VAC	8
<b>UOA-240-AFN</b>	202 VAC	210 VAC	8

\*ADJUSTMENTS F = Fixed, K = Knob, L = Locknut

## WIRING



WIRING DIAGRAMS (SHOWN IN DE-ENERGIZED STATE)

PLUG-IN MODEL Style A

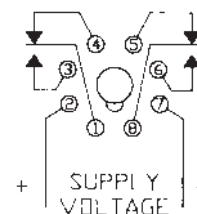

(DC POLARITY SHOWN) RB-08 or PF083A

SURFACE MOUNTED Style N

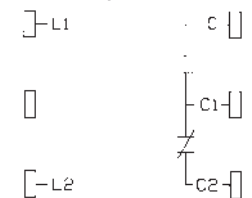

The VBA Series offers protection to **single phase** equipment that is required to operate between two voltage limits. Supply voltage is monitored for a preselected **UNDER** and **OVER** voltage limit.

## OPERATION

With normal operating voltage applied, the internal relay will energize (PICK-UP). When the voltage falls outside the preset Over/Under trip points for longer than the release delay, the relay will de-energize (DROP-OUT). When line conditions return to normal, the VBA Series automatically resets and the internal relay energizes.

The HYSTERESIS in each unit on the Under and Over limits provides a differential between the PICK-UP and DROP-OUT trip points.

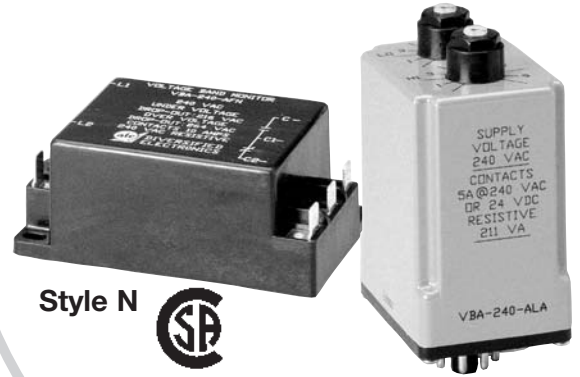

Style N

Style A   
Style A Only

Single Phase Voltage Band Monitor

## WIRING

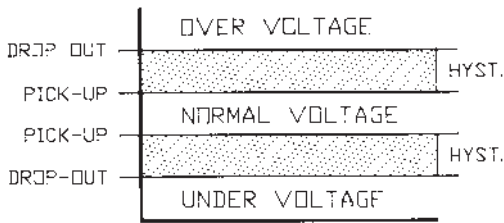

### WIRING DIAGRAMS (SHOWN IN DE-ENERGIZED STATE)

PLUG-IN MODEL  
Style A

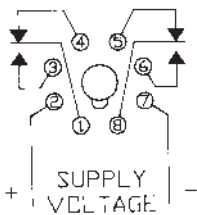

(DC POLARITY SHOWN)  
RB-08 or PF083A

SURFACE MOUNTED  
Style N

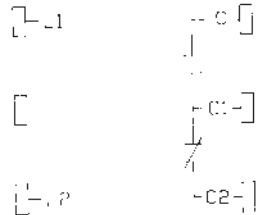

## SPECIFICATIONS

POWER REQUIRED	Models Up To 110 VDC: 3 Watts, Max.	
	Models Up To 300 VAC: 5 VA, Max.	
OUTPUT RATING	Style A	DPDT, 5A @ 240 VAC, Resistive; 211 VA @ 240, Inductive.
	Style N	SPDT, 10A @ 240 VAC, Resistive; 180 VA, Inductive.
RESPONSE TIMES	Operate	50 mSEC (approx.) (500 mSEC on 12 VDC units)
	Release	0.5 SEC (approx.)
TEMPERATURE RATING	Operate	32° to +131°F (0° to +55°C)
	Storage	-49° to 185°F (-45° to +85°C)
WEIGHT	5 oz.	

MODEL NUMBER	NOMINAL VOLTAGE	PICK-UP UNDER VOLTAGE	PICK-UP OVER VOLTAGE	HYSTERESIS VOLTAGE
VBA-24-A*A	24 VAC	19-24	24-29	2
VBA-120-A*A	120 VAC	90-120	120-150	5
VBA-208-A*A	208 VAC	185-208	208-240	8
VBA-240-A*A	240 VAC	200-240	240-270	10
VBA-12-D*A	12 VDC	10-12	12-15	1
VBA-24-D*A	24 VDC	19-24	24-29	1
VBA-28-D*A	28 VDC	22-28	28-34	1
VBA-48-D*A	48 VDC	38-48	48-58	2
VBA-110-D*A	110 VDC	85-110	110-135	5
VBA-24-AFN	24 VAC	21.6	26.4	0
VBA-120-AFN	120 VAC	108	132	0
VBA-208-AFN	208 VAC	187	229	0
VBA-220-AFN	208/240 VAC	198	242	0
VBA-230-AFN	230 VAC	207	253	0
VBA-240-AFN	240 VAC	216	264	0

\*ADJUSTMENTS F = Fixed, K = Knob, L = Locknut

## WIRING DIAGRAMS

**FIGURE 1**

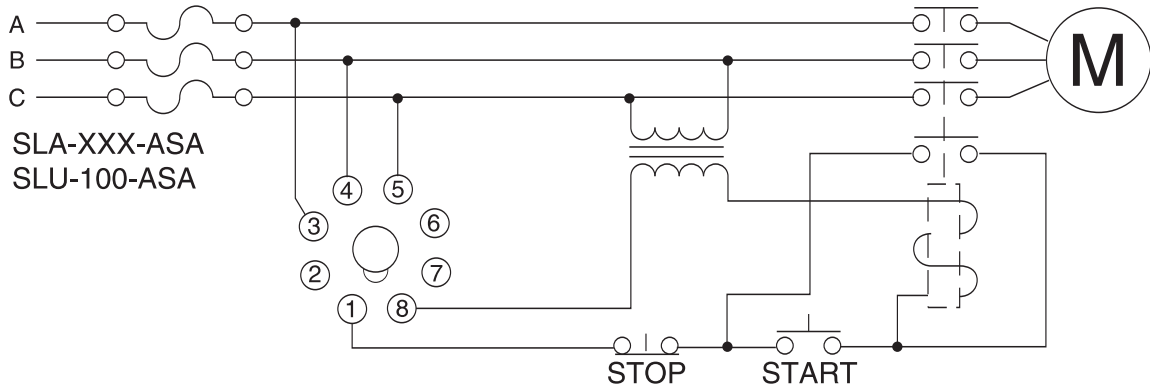

**FIGURE 2**

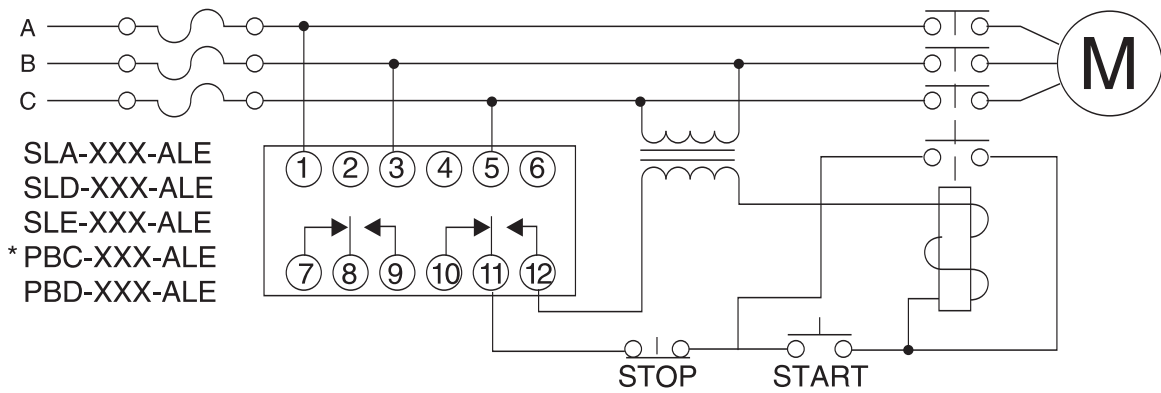

**FIGURE 3**

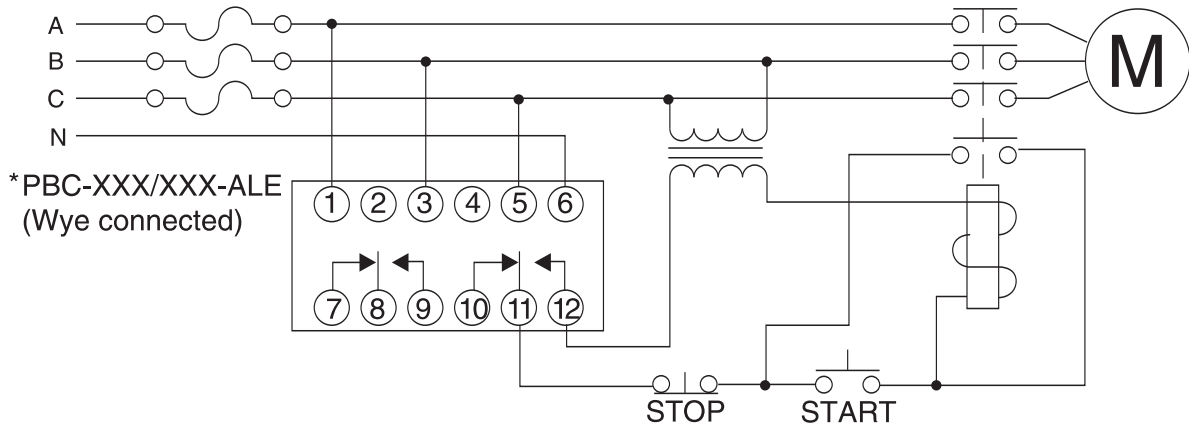

APPLICATION NOTES—WIRING DIAGRAMS

FIGURE 4

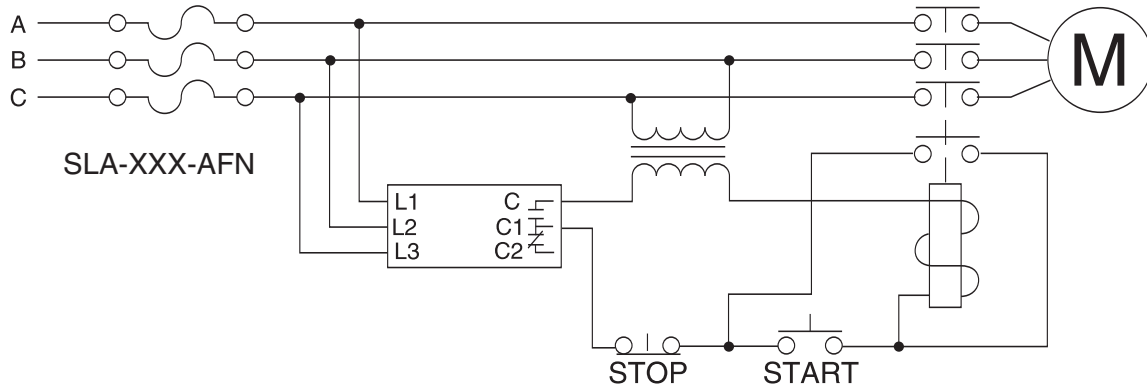

FIGURE 5

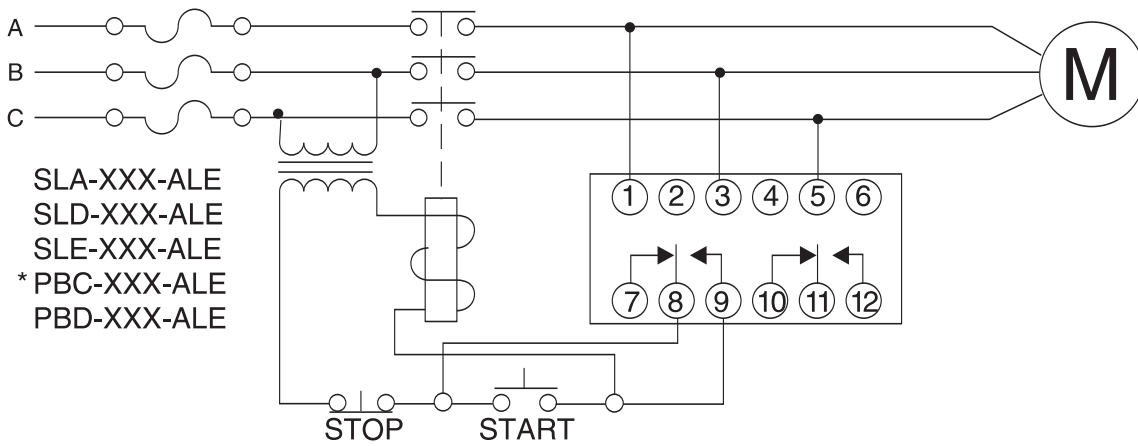

FIGURE 6

