

Timer Selection

Timer Selection Guides

- Relay Output..... 2.2
- Solid State Output..... 2.4

Timer Function Selection

- Selecting a Function..... 2.6
- Selection Questions..... 2.6
- Understanding Time Diagrams..... 2.6
- International Timing Function Symbols..... 2.7

Popular Functions

- (M) -- Delay on Make..... 2.7
- Extra Functions Included in Some Delay on Make Timers..... 2.7
- (AM) -- Accumulative Delay on Make..... 2.7
- (I) -- Interval..... 2.7
- Extra Functions Included in Some Interval Timers..... 2.7
- (RE, RD, RXE, RXD) -- Recycling..... 2.8
- Extra Functions Included in Some Recycling Timers..... 2.8
- (B) -- Delay on Break..... 2.8
- Extra Functions Included in Some Delay on Break Timers..... 2.8
- (UB) -- Inverted Delay on Break..... 2.8
- (S, SD) -- Single Shot..... 2.9
- Extra Functions Included in Some Single Shot Timers..... 2.9
- (PSD) -- Retriggerable Single Shot (Motion Detector)..... 2.9
- (PSE) -- Retriggerable Single Shot (Motion Detector)..... 2.9
- (US) -- Inverted Single Shot..... 2.9
- (TS) -- Trailing Edge Single Shot (Impulse-OFF)..... 2.9

Two Functions in One Timer

- (MB) -- Delay on Make/Delay on Break..... 2.10
- Extra Functions Included in Some Delay on Make/Delay on Break Timers..... 2.10
- (MI) -- Delay on Make/Interval..... 2.10
- (AMI) -- Accumulative Delay on Make/Interval..... 2.10
- (MRE) -- Delay on Make/Recycle..... 2.11
- (MS) -- Delay on Make/Single Shot..... 2.11
- (IRE) -- Interval/Recycle..... 2.11
- (BRE) -- Delay on Break/Recycle..... 2.11
- (SRE) -- Single Shot/Recycle..... 2.11
- (SL) -- Single Shot/Lockout..... 2.11
- (IM) -- Interval/Delay on Make..... 2.11

Counting and Switching Functions

- (F) -- Flip-Flop, Leading Edge..... 2.12
- (FT) -- Alternating Relay (Trailing Edge Flip-Flop)..... 2.12
- (C) -- Counter/Pulsed Output..... 2.12
- (CI) -- Counter/Interval Output..... 2.12

Selection Guide

Solid State Timers with Relay Outputs

2

For detailed product specifications, refer to catalog pages.



	Plug-in Switch Adjust		Plug-in Knob Adjust		HR Series Onboard & External Adjust or Fixed		ERD Series Knob & External Adjust or Fixed		OR Series Knob & External Adjust or Fixed	
	Series	Page	Series	Page	Series	Page	Series	Page	Series	Page
Dedicated Function										
Delay on Make (ON Delay)	TDM	5.2	TRM PRLM	5.4 5.6	HRDM HRPS	5.8 3.10	ERDM	5.10	ORM	5.12
Interval (Impulse ON)	TDI	5.100	TRS PRLS	5.72 5.74	HRDI HRPS	5.102 3.10	ERDI	5.104	ORS	5.80
Recycling Equal Times			TRU	4.6	HRD3 (e) HRPS	5.130 3.10	ERD3 (e)	5.132		
Recycling Unequal Time (Pulse Generator)	TDR	5.126			HRDR HRPD	5.128 3.8				
Recycling (Pulse Generator)					HRDS HRD9 (r) HRPS	5.76 5.96 3.10	ERDI	5.104	ORS	5.80
Single Shot (Pulse Former)	TDS	5.70	TRS PRLS	5.72 5.74	HRDB HRPS	5.48 3.10			ORB	5.50
Delay on Break (OFF-delay)	TDB	5.42	TRB PRLB	5.44 5.46	HRPD HRPD	3.8 3.8				
Delay on Make / Delay on Break	TDMB	5.156				See Section 3				
Delayed Interval (Single Pulse Generator)	TRDU	4.4								
Other Functions Available		•		•						
Multifunction	See Section 4		See Section 4							
Time Delay & Adjustment										
Time Delay Range	0.1 s to 2.8 h (!) TRDU to 1705 h		0.05 s to 10 m (!) TRU 16 h		0.1 s to 1000 m		0.1 s to 500 m (!)		0.05 to 300 s (!)	
Repeat Accuracy	≤ 0.1%		≤ 2%		≤ 0.5%		≤ 0.5% to 2%		≤ 2%	
Knob Adjust			•							
Onboard Adjust					•					
Switch Adjust	•									
External Adjust			TR Series							
Factory Fixed			TR Series							
General Features										
DIN Rail Mounting (35 mm)	Socket Required		Socket Required		Adaptor Required					
Surface Mounting	Socket Required		Socket Required		•					
Output Relay	SPDT or DPDT		SPDT or DPDT		SPDT		SPDT or DPDT		SPDT or DPDT	
Resistive Rating at Contacts	10 A		10 A		30 A					
Screw Terminals	Socket Required		Socket Required							
DPDT Relay/Resistive Rating							10 A		10 A	
SPDT Relay/Resistive Rating					30 A		10 A		10 A	
Popular AC & DC Voltages	•		•		•		•		ORB, ORS AC Only	
Encapsulated					•		•			
Quick Connects					•		•			
Dimensions	in	1.78 x 2.39 x 3.20	in	1.78 x 2.39 x 3.62	in	2.02 x 3.02 x 1.50	in	2.50 x 3.50 x 1.70	in	2.12 x 3.69 x 1.88
	mm	45.2 x 60.7 x 81.3	mm	45.2 x 60.7 x 91.6	mm	51.3 x 76.7 x 38.1	mm	63.5 x 88.9 x 43.2	mm	53.9 x 93.7 x 47.8

(a) = includes time accumulation; (e) = equal time delays (see Flashers Selection Guide for more options); (!) = includes an instantaneous contact; (tb) = true delay on break; (te) = trailing edge triggered; A = amps resistive rating; (!) = most series consult catalog pages; (r) = retriggerable

Selection Guide

Solid State Timers with Relay Outputs

Timer
Selection

For detailed product specifications, refer to catalog pages.

**KR Series
Onboard &
External Adjust
or Fixed**



Dedicated Function	Series	Page
Delay on Make (ON-Delay)	KRDM KRPS	5.14 3.6
Interval (Impulse ON)	KRDI KRPS	5.106 3.6
Interval, Trailing Edge (Impulse OFF)		
Interval, True Trailing Edge (Impulse OFF)		
Recycling Equal Times	KRD3 (e) KRPS	5.136 3.6
Recycling (Pulse Generator)	KRDR KRPD	5.134 3.4
Recycling, Unequal Times (Pulse Generator)		
Single Shot (Pulse Former)	KRDS KRD9 (r)	5.82 5.98
Delay on Break (OFF - delay)	KRDB KRPS	5.52 3.6
True Delay on Break (OFF - delay)		
Delay on Make / Delay on Break	KRPD	3.4
Star Delta		
Delayed Interval (Single Pulse Generator)	KRPD	3.4
Other Functions Available	See Section 3	
Time Delay & Adjustment		
Time Delay Range	100 m to 1000 h	
Repeat Accuracy	≤ 0.5%	
Knob Adjust		
Onboard Adjust	•	
Switch Adjust		
External Adjust	•	
Factory Fixed	•	
General Features		
DIN Rail Mounting (35 mm)	Adaptor Required	
Surface Mounting	•	
Popular AC & DC Voltages		
Encapsulated		
Quick Connects	•	
Output Relay	SPDT	
Resistive Rating at Contacts	10 A	
Screw Terminals		
Dimensions	in mm	2.0 x 2.0 x 1.21 50.8 x 50.8 x 30.7

(e) = equal time delays; (r) = retriggerable; (!) = Most series consult catalog pages; (i) = includes an instantaneous contact on some series

Selection Guide

Solid State Timers with Solid State Output

2

For detailed product specifications, refer to catalog pages.

Digi-Timer
Onboard,
Switch, Fixed, or
External Adjust



MicroTime
Onboard or
Switch Adjust



Digi-Timer
Onboard,
Switch, Fixed or
External Adjust



Onboard, Fixed,
or
External Adjust



	Digi-Timer Onboard, Switch, Fixed, or External Adjust		MicroTime Onboard or Switch Adjust		Digi-Timer Onboard, Switch, Fixed or External Adjust		Onboard, Fixed, or External Adjust	
	Series	Page	Series	Page	Series	Page	Series	Page
Dedicated Function								
Delay on Make (ON Delay)	TSD1 KSD1	5.20 5.26			TDU KSDU	5.16 5.16	TMV/TSU TS1	5.18 5.28
Delay on Make Normally Closed	TSD4 KSD4	5.34 5.38					TS4	5.40
Delay on Break (OFF-delay)	TSDB KSDB	5.56 5.60	ASQU/ASTU DSQU/DSTU	4.8 4.10	TDUB	5.54	TSB	5.66
Delay on Break (2 Terminal)	TSDB	5.56						
Single Shot (Pulse Former)	TSD7 TSDS KSDS	5.62 5.86 5.90	ASQU/ASTU DSQU/DSTU	4.8 4.10	TDUS	5.84	TSS	5.92
Single Shot (Motion Detector)	KSPS (r)	3.18						
Interval (Impulse ON)	TSD2 KSD2	5.110 5.120	ASQU/ASTU DSQU/DSTU	4.8 4.10	TDUI	5.108	TS2	5.122
Interval (DC Volts Only)	TSD6 (d)	5.114					TS6 (d)	5.122
Interval (2 Terminal)	TSDB	5.56						
Recycling (Delays Separately Adjustable)	ESDR TSDR (f) KSDR	5.140 5.142 5.144						
Recycling (Equal Delays)	TSD3 (e) KSD3 (e)	5.148 5.150	ASQU/ASTU DSQU/DSTU	4.8 4.10				
Delay on Make/ Delay on Break	KSPD	3.16						
Delay on Make/Interval	ESD5	5.158						
Other Functions Available	KSPD	3.16						
	See Section 3							
Multifunction								
Time Delay & Adjustment								
Typical Time Delay Range	0.1 s to 1000 m		0.1 s to 100 m (!)		0.1 s to 170 m (!)		0.05 to 600 s	
Repeat Accuracy	≤ 0.1 to 1%		≤ 0.1 to 1%		≤ 0.5%		≤ 0.5 to 2%	
Onboard Adjustment	•		AS_U Series		Most Series (!)		Some (!)	
Switch Adjustment	KSPU	3.20	DS_U Series					
External Adjustment	•						•	
Factory Fixed	Except KSDR Series				KSDU Series		•	
General Features								
DIN Rail Mounting	Adaptor Required		•		Adaptor Required		Adaptor Required	
Surface Mounting	•		•		•		•	
Output Rating	1 A		0.7 A		1 A		1A	
Popular AC Voltages	•		•		•		•	
Popular DC Voltages	•		•		•		•	
Screw Terminals	•		•		•		•	
Quick Connects	•		•		•		•	
Dimensions	in	2.0 x 2.0 x 1.21	0.69 x 3.0 x 2.41		2.0 x 2.0 x 1.21		2.0 x 2.0 x 1.21	
	mm	50.8 x 50.8 x 30.7	17.5 x 76.2 x 61.2		50.8 x 50.8 x 30.7		50.8 x 50.8 x 30.7	

(d) = DC Volts Only; (e) = equal time delays; (s) = 3 or 4 channel sequencer; (!) = most series consult catalog pages;
(r) = retriggerable; (f) = at least one delay must be specified as fixed

Selection Guide Solid State Timers

Timer
Selection

For detailed product specifications, refer to catalog pages.

Digi-Power
Onboard, Fixed
or
External Adjust



Digi-Set
Switch Adjust



PC Mount /
Wires Fixed



Surface Mount
2.5 x 3.5



Dedicated Function	Series	Page	Series	Page	Series	Page	Series	Page
Delay on Make (ON Delay)	THDM	5.22			MSM	5.32		
	THD1	5.24						
	TH1	5.30						
Delay on Make Normally Closed	THD4	5.36						
Delay on Break (OFF - delay)	THDB	5.58						
Single Shot (Pulse Former)	THDS	5.88						
	THS	5.94						
Interval (Single Pulse on Operate)	THD2	5.112						
	TH2	5.124						
Interval (DC Volts Only)								
Interval (2 Terminal)	THD7	5.118						
Recycling (Delays Separately Adjust)	NHPD	3.22	RS	5.138				
Recycling (Equal Delays)	THD3	5.146					SQ (s) (e)	5.154
Percentage	PTHF	5.152						
Delay on Make/ Delay on Break	NHPD	3.22						
Delay on Make/Interval	NHPD	3.22						
Other Functions Available	See Section 3							
Multifunction								
Time Delay Adjustment								
Typical Time Delay Range	0.1 s to 1000 m		0.1 s to 1023 h		0.05 to 180 s		0.1 s to 100 m	
Repeat Accuracy	≤ 0.5%		≤ 0.1%		≤ 5%		≤ 1%	
Onboard Adjustment	Most (!)						•	
Switch Adjustment	NHPU 3.26		•				•	
External Adjustment	•						•	
Factory Fixed	•				•		•	
General Features								
DIN Rail Mounting								
Surface Mounting	•		•		•		•	
Output Rating	6, 10, or 20 A		1 A		0.5 A		1 A	
Popular AC Voltages	•		•		•		•	
Popular DC Voltages	Delay On Make Only		•		•		•	
Screw Terminals					2 Wire Leads or PC Board Mount			
Male Quick Connects	•		•				•	
Dimensions	in 2.0 x 2.0 x 1.51		3 x 2 x 1.5		0.94 x 1.5		2.5 x 3.5 x 1.22	
	mm 50.8 x 50.8 x 38.4		76.7 x 50.8 x 38.1		23.8 x 38.1		63.5 x 88.9 x 31	

(d) = DC Volts only; (e) = equal time delays; (s) = 3 or 4 channel sequencer; (!) Some Series consult catalog pages

Timer Functions

Selecting a Function

Selecting a Timer's Function

Selecting one of the five most common timing functions can be as easy as answering three questions on the chart below. If you have trouble answering these questions, try drawing a connection diagram that shows how the timer and load are connected. Time diagrams and written descriptions of the five most popular functions, plus other common functions appear on the following pages. Instantaneous contacts, accumulation, pause timing functions, and flashing LED's are included in some units to expand the versatility of the timer. These expanded operations are explained on the product's catalog page. Time diagrams are used on these pages along with text and international symbols for functions.

Function Selection Guide

Selection Questions

- 1) The timing starts when the initiate (starting) contacts are:
A) Closed B) Opened
- 2) What is the status of the output (or load) during timing:
A) On B) Off C) On/Off
- 3) Will the load de-energize (or remain de-energized) if the initiate (starting) contacts are opened during timing:
A) Yes B) No

THE FIVE MOST USED FUNCTIONS

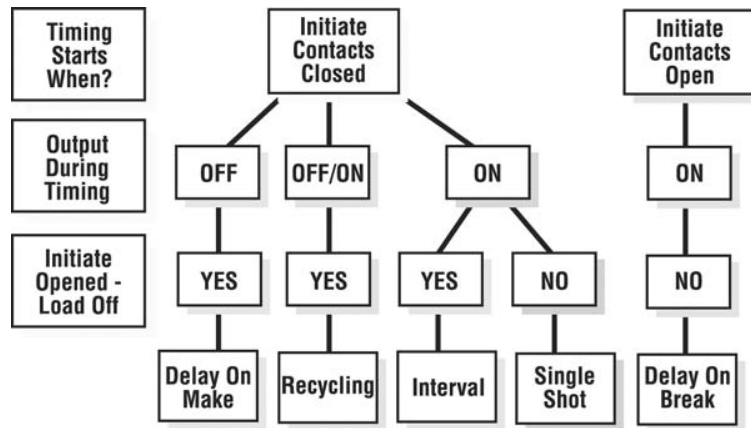

Understanding Time Diagrams

Time diagrams are used to show the relative operation of switches, controls, and loads as time progresses. Time begins at the first vertical boundary. There may be a line indicating the start of the operation or it may just begin with the transition of the device that starts the operation. Each row in the time diagram represents a separate component. These rows will be labeled with the name of the device or its terminal connection numbers. In a bistable or digital system, the switches, controls, or loads can only be ON or OFF. The time lines are drawn to represent these two possible conditions. Vertical lines are used to define important starting or ending points in the operation.

The example to the right is the most common type of time diagram in use in North America. It shows the energizing of loads, and the closing of switches and contacts by an ascending vertical transition of the time line. Opening switches or contacts or de-energizing loads are represented by descending vertical transitions.

TIME DIAGRAM

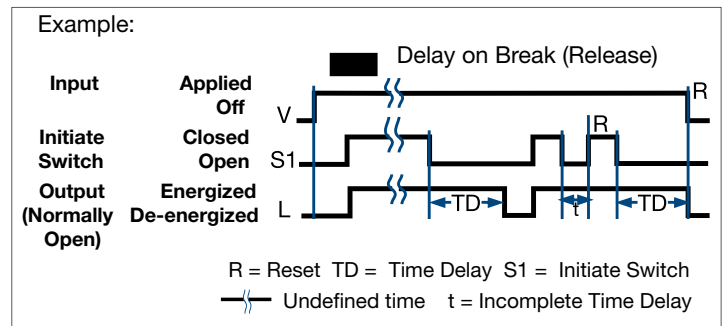

Timer Functions Popular Functions

INTERNATIONAL TIMING FUNCTION SYMBOLS

- ☒ = Delay on Make; ON-delay
- = Delay on Break; OFF-delay
- ☒ ■ = Delay on Make & Break; ON and OFF-delay
- 1 □ = Interval; Impulse-ON
- 1 □ = Trailing Edge Interval; Impulse-OFF
- = Single Shot; Pulse Former
- ☒ = Flasher - ON Time First; Recycling Equal Times - ON First
- ■ = Flasher - OFF Time First; Recycling Equal Times - OFF First
- ☒ = Recycling - Unequal Times; Pulse Generator
- ☒ = Recycling - Unequal Times Starting with ON or OFF
- ☒ = Delay on Make & Interval; Single Pulse Generator
- △ ☒ = Star-delta Motor Starting - Twice Delayed on ON
- △ 1 □ = Star-delta Motor Starting - with Impulse-ON
- △ ☒ = Star-delta Motor Starting

Delay on Make: (ProgramaCube® Function M)

(ON-delay, Delay on Operate, On Delay, Operate Delay, Delay On, Prepurge Delay)

OPERATION: Upon application of input voltage, the time delay begins. The output (relay or solid state) is de-energized before and during the time delay. At the end of the time delay, the output energizes and remains energized until input voltage is removed.

RESET: Removing input voltage resets the time delay and output.

See: HRRPS, KRPS, KSPS, KSPU, NHPS, NHPU, TDM, TRDU

Extra Functions Included in Some Delay on Make (DOM) Timers:

Accumulating Time Delay Feature: (ProgramaCube® Function AM) Some DOM timers allow the time delay to be stopped and held and then resumed by opening and closing an external switch. The total time delay, TD is the sum of the accumulated partial time delays, "t".

See: KRPD, KRPS, HRRPS, NHPS, KSPD, KSPS, TRDU, CT-ERS, CT-MBS, CT-MFS

Instantaneous Contacts: Some DOM timers have a set of instantaneous contacts in addition to the delayed contacts. Instantaneous contacts energize when input voltage is applied and remain until voltage is removed.

Delay on Make, Normally Closed Output: All relay output delay on make timers with normally closed contacts include this function. (See Delay on Make NC Contacts) This function is also available in solid state output timers. The solid state output energizes when input voltage is applied. The time delay begins when an optional initiate switch S1 is closed (timing starts when voltage is applied if S1 is not used). The output de-energizes at the end of the time delay.

Reset: Opening S1 resets the time delay and the output immediately energizes (or remains energized). Removing input voltage resets the time delay and de-energizes the output.

See: KSD4, THD4, TS4, TSD4

Interval: (ProgramaCube® Function I)

(Impulse-ON, Single Pulse on Operate, On Interval, Interval On, Pulse Shaping, Bypass Timing)

OPERATION: Upon application of input voltage, the time delay begins. The output (relay or solid state) energizes during the time delay. At the end of time delay the output de-energizes and remains de-energized until input voltage is removed.

RESET: Removing input voltage resets the time delay and output.

See: HRRPS, KRPS, KSPS, KSPU, NHPS, NHPU, TDI, TSD2

Extra Functions Included on Some Interval Timers:

Instantaneous Contacts: Some Interval timers have a set of instantaneous contacts in addition to the delayed contacts. Instantaneous contacts energize when input voltage is applied and remain until voltage is removed.

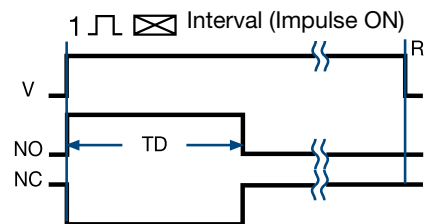
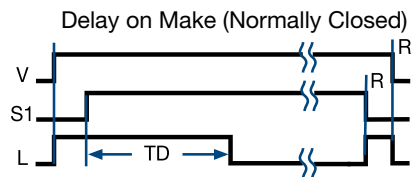
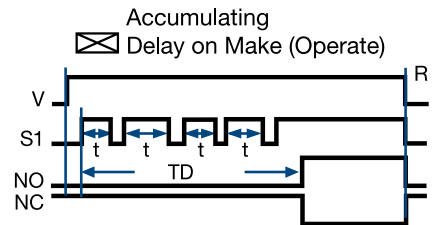
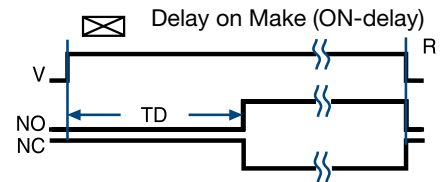

Legend

- V = Voltage
- R = Reset
- TD = Time Delay
- S1 = Initiate Switch
- NO = Normally Open Contact
- NC = Normally Closed Contact
- t = Incomplete Time Delay
- L = Load
- }— = Undefined time

Timer Functions Popular Functions

2

Recycling: (ProgramaCube® Functions RE, RD, RXE, RXD) (Flasher, Pulse Generator, Recycle Timing, Repeat Cycle, Duty Cycling)

OPERATION: Upon application of input voltage, the output (relay or solid state) energizes and the ON time begins. At the end of the ON time, the output de-energizes and the OFF time begins. At the end of the OFF time, the output energizes and the cycle repeats as long as input voltage is applied. The OFF time may be the first delay in some recycling timers.
RESET: Removing input voltage resets the output and time delays, and returns the sequence to the first delay.

The time delays in some recycling timers are equal $TD1=TD2$. Flashers are an example of this type of recycling timer. Others have separately selectable time delays.

See: HRPD, HRPS, KRPD, KRPS, KSPD, KSPS, KSPU, NHPD, NHPS, NHPU, TDR

Extra Functions Included in Some Recycling Timers:

Instantaneous Contacts: Some Recycling timers have a set of instantaneous contacts in addition to the delayed contacts. Instantaneous contacts energize when input voltage is applied and remain until voltage is removed.

Delay on Break: (ProgramaCube® Function B) (Delay on Release, OFF-delay, Release Delay, Postpurge Delay)

OPERATION: Input voltage must be applied before and during timing. Upon closure of the initiate switch, the output (relay or solid state) energizes. The time delay begins when the initiate switch is opened. The output remains energized during timing. At the end of the time delay, the output de-energizes. The output will energize if the initiate switch is closed when input voltage is applied.

RESET: Reclosing the initiate switch during timing resets the time delay. Removing input voltage resets the time delay and output.

See: HRPS, HRPV, KRPS, KSPS, KSPU, NHPS, NHPU, TRDU, TDB

Extra Functions Included in Some Delay on Break (DOB) Timers:

Instantaneous Contacts: Some DOB timers have a set of instantaneous contacts in addition to the delayed contacts. Instantaneous contacts energize when input voltage is applied and remain until voltage is removed.

Related Functions:

Inverted Delay on Break: (ProgramaCube® Function UB)

OPERATION: Input voltage must be applied before and during timing. Upon closure of the initiate switch S1, the output (relay or solid state) de-energizes. The time delay begins when S1 is opened. The output remains de-energized during timing. At the end of the time delay, the output energizes. The output remains de-energized if S1 is closed when input voltage is applied.

RESET: Reclosing S1 during timing resets the time delay. Removing input voltage resets the time delay and output.

See: HRPS, HRPV, KRPS, KSPS, KSPU, NHPS, NHPU, TRDU

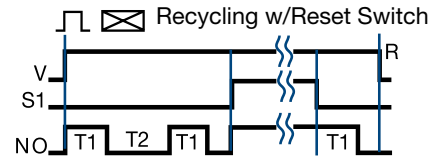
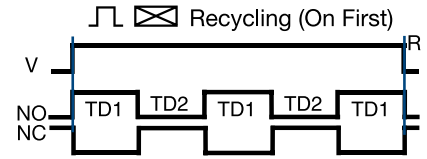

S1 = Reset Switch

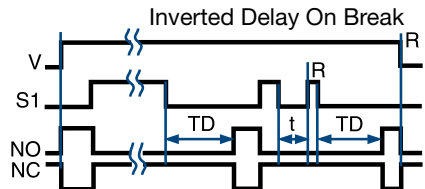
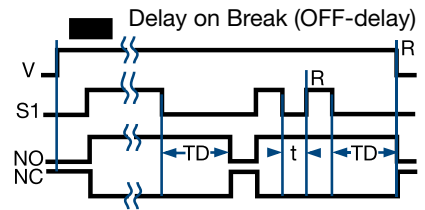

Legend

V = Voltage
R = Reset
T1 = ON Time
T2 = OFF Time
S1 = Initiate Switch
NO = Normally Open Contact
NC = Normally Closed Contact
t = Incomplete Time Delay
TD, TD1, TD2 = Time Delay
— = Undefined Time

Timer Functions

Popular Functions

Single Shot: (ProgramaCube® Functions S or SD)

(Pulse Former, One Shot Relay, Single Shot Interval, Pulse Shaping)

OPERATION: Input voltage must be applied before and during timing. Upon momentary or maintained closure of the initiate switch, the output (relay or solid state) energizes and the time delay begins. At the end of the delay, the output de-energizes. Opening or reclosing the initiate switch during timing has no effect on the time delay. Note (for most single shot timers): If the initiate switch is closed when input voltage is applied, the output energizes and the time delay begins.

RESET: Reset occurs when the time delay is complete and the initiate switch is opened.

Removing input voltage resets the time delay and output.

See: HRPS, HRPV, KRPS, KSPS, KSPV, NHPS, NHPV, TDS, TSDS, TRDU

Extra Functions Included in Some Single Shot Timers:

Instantaneous Contacts: Some Single Shot timers have a set of instantaneous contacts in addition to the delayed contacts. Instantaneous contacts energize when input voltage is applied and remain until voltage is removed.

Related Functions:

Retriggerable Single Shot (Motion Detector): (ProgramaCube® Function PSD)

(Motion Detector, Zero Speed Switch, Watchdog Timer, Missing Pulse Timer)

OPERATION: Input voltage must be applied prior to and during timing. The output (relay or solid state) is de-energized. When the initiate switch S1 closes momentarily or maintained, the output energizes and the time delay begins. Upon completion of the delay, the output de-energizes.

RESET: Reclosing S1 resets the time delay and restarts timing. Removing input voltage resets the time delay and output.

See: HRD9, HRPV, HRPV, KR9, KRPS, KSPS, KSPV, NHPS, NHPV, TRDU, TRU

Retriggerable Single Shot (Motion Detector): (ProgramaCube® Function PSE)

OPERATION: Similar to retriggerable single shot function PSD above except, when input voltage is applied, the output (relay or solid state) immediately energizes and timing begins. At the end of the time delay, the output de-energizes. The unit will timeout as long as S1 remains open or closed for a full time delay period.

RESET: During timing, reclosing S1 resets and restarts the time delay and the output remains energized. After timeout, reclosing S1 starts a new operation. Removing input voltage resets the time delay and the output. See: KR9

Inverted Single Shot: (ProgramaCube® Function US)

OPERATION: Input voltage must be applied before and during timing. Upon momentary or maintained closure of the initiate switch S1, the output (relay or solid state) de-energizes. At the end of the time delay, the output energizes. Opening or reclosing S1 during timing has no effect on the time delay. The output will remain de-energized if S1 is closed when input voltage is applied.

RESET: Reset occurs when the time delay is complete and S1 is open. Removing input voltage resets the time delay and output.

See: HRPS, HRPV, KRPS, KSPS, KSPV, NHPS, NHPV, TRDU

Trailing Edge Single Shot (Impulse-OFF): (ProgramaCube® Function TS)

OPERATION: Input voltage must be applied before and during timing. When the initiate switch S1 opens, the output (relay or solid state) energizes. At the end of the time delay, the output de-energizes. Reclosing and opening S1 during timing has no effect on the time delay. The output will not energize if S1 is open when input voltage is applied.

RESET: Reset occurs when the time delay is complete and S1 is closed. Removing input voltage resets the time delay and output.

See: HRPS, KRPS, KSPS, KSPV, NHPV, TRDU, CT-AWS, CT-MBS, CT-MFS, CT-MVS

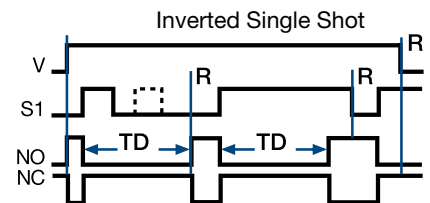
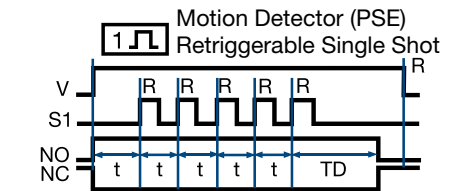
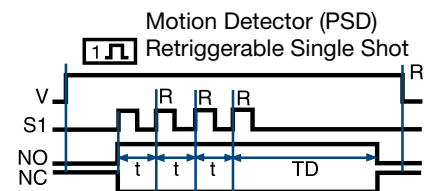
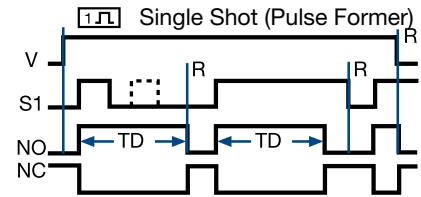

Timer Functions Two Functions in One Timer

2

Delay on Make/Delay on Break: (ProgramaCube® Function MB)

(ON-delay/OFF-delay, Delay on Operate/Delay on Release, Sequencing ON & OFF, Fan Delay, Prepurge & Postpurge)

OPERATION: Input voltage must be applied at all times. The output (relay or solid state) is de-energized. Upon closure of the S1 initiate switch, the delay on make time delay (TD1) begins. At the end of TD1, the output (relay or solid state) energizes. Opening S1 starts the delay on break time delay (TD2). At the end of TD2, the output de-energizes.

RESET: Removing input voltage resets time delays and the output. If S1 is a) opened during TD1, then TD1 is reset and the output remains de-energized. b) reclosed during TD2, then TD2 is reset and the output remains energized.

See: HRPD, KRPD, KSPD, NHPD, CT-EAS, CT-EVS

Extra Functions Included in Some Delay on Make/Delay on Break Timers:

Instantaneous Contacts: Some DOM/DOB timers have a set of instantaneous contacts in addition to the delayed contacts. Instantaneous contacts energize when input voltage is applied and remain until voltage is removed.

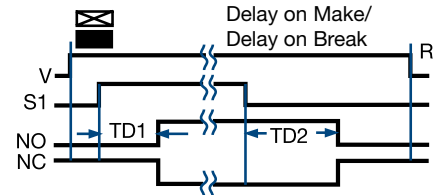

Delay on Make/Interval: (ProgramaCube® Function MI)

(Single Pulse Generator, Delayed Interval, Delay on Operate/Single Pulse on Operate)

OPERATION: Upon application of input voltage, the delay on make time delay (TD1) begins, the output remains de-energized. At the end of this delay, the output (relay or solid state) energizes and the interval delay (TD2) begins. At the end of the interval delay (TD2), the output de-energizes.

RESET: Removing input voltage resets the output, the time delays and returns the sequence to the first delay.

See: ESD5, HRPD, KRPD, KSPD, NHPD, TRDU

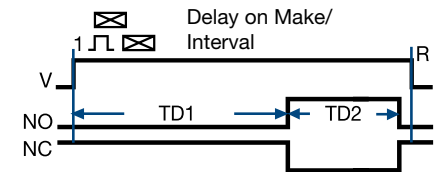

Accumulative Delay on Make/Interval: (ProgramaCube® Function AMI)

OPERATION: Input voltage must be applied before and during timing. The output is de-energized before and during the TD1 time delay. Each time S1 closes, the time delay progresses; when it opens, timing stops. When the amount of time S1 is closed equals the full TD1 delay, the output (relay or solid state) energizes for TD2. Upon completion of TD2, the output relay de-energizes. Opening S1 during TD2 has no affect.

RESET: Removing input voltage resets the time delay, output relay, and the sequence to the first delay.

See: HRPD, KRPD, KSPD, NHPD

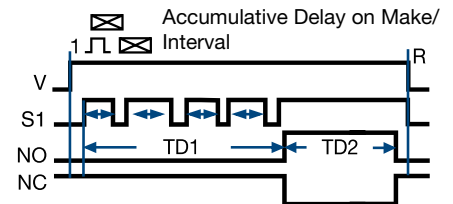

Legend

V = Voltage	R1 = Wye Start Relay
S1 = Initiate Switch	NO = Normally Open
TS = Start Delay	NC = Normally Closed
R = Reset	TP = 50ms Pause Delay
TD1, TD2 = Time Delay	R2 = Delta Run Relay

// = Undefined Time

Timer Functions

Two Functions in One Timer

Timer Selection

2

Delay On Make/Recycle: (ProgramaCube® Function MRE)

OPERATION: Upon application of input voltage, TD1 begins and the output (relay or solid state) remains de-energized. At the end of TD1, the TD2 recycle function begins and the output (relay or solid state) cycles ON and OFF for equal delays. This cycle continues until input voltage is removed.

RESET: Removing input voltage resets the output and time delays, and returns the sequence to the first delay. See: KSPD, KRPD, NHPD, HRPD, TRDU

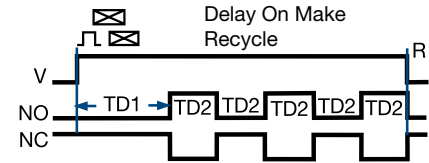

Delay On Make/Single Shot: (ProgramaCube® Function MS)

OPERATION: Upon application of input voltage and the closure of S1, TD1 begins and the output (relay or solid state) remains de-energized. The output (relay or solid state) energizes at the end of TD1, and TD2 begins. At the end of TD2, the output (relay or solid state) de-energizes. Opening or reclosing S1 during timing has no effect on the time delays.

RESET: Reset occurs when the time delay is complete and S1 is open. Removing input voltage resets the time delay, output, and the sequence to the first delay.

See: KSPD, KRPD, NHPD, HRPD, TRDU

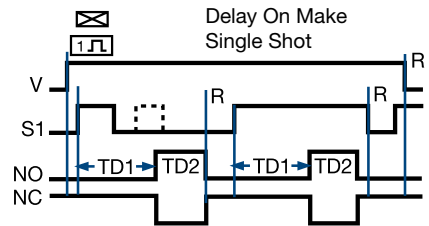

Interval/Recycle: (ProgramaCube® Function IRE)

OPERATION: Upon application of input voltage TD1 begins. At the same time, the TD2 ON time begins and the output (relay or solid state) energizes. At the end of the ON time, the TD2 OFF time begins and the output de-energizes. The equal ON time OFF time cycle continues until TD1 is completed at which time the output de-energizes.

RESET: Removing input voltage resets the time delays, output, and the sequence to the Interval function. See: KSPD, KRPD, NHPD, HRPD, TRDU

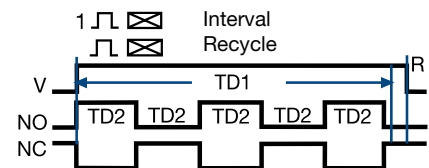

Delay On Break/Recycle: (ProgramaCube® Function BRE)

OPERATION: Upon application of input voltage and the closure of S1, the TD2 ON time begins and the output (relay or solid state) energizes. Upon completion of the ON time, the output de-energizes for the TD2 OFF time. At the end of the OFF time, the equal ON/OFF cycle repeats. When S1 opens, the TD1 delay begins. TD1 and TD2 run concurrently until the completion of TD1 at which time, the TD2 ON/OFF cycle terminates and the output de-energizes. The output energizes if S1 is closed when input voltage is applied.

RESET: Reclosing S1 during timing resets the TD1 time delay. Removing input voltage resets the time delay, output, and the sequence to the Delay on Break function.

See: KSPD, KRPD, NHPD, HRPD, TRDU

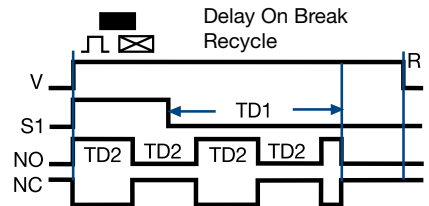

Single Shot/Recycle: (ProgramaCube® Function SRE)

OPERATION: Upon application of input voltage and the closure of S1, TD1 begins. At the same time, the TD2 ON time begins and the output (relay or solid state) energizes. Upon completion of the ON time, the output de-energizes for the TD2 OFF time. At the end of the OFF time, the equal ON/OFF cycle repeats. TD1 and TD2 run concurrently until the completion of TD1 at which time, the TD2 ON/OFF cycle terminates and the output de-energizes. Opening or reclosing S1 during timing has no effect on the time delays. The output will energize if S1 is closed when input voltage is applied.

RESET: Removing input voltage resets the time delay, output, and the sequence to the first delay. See: HRPD, KRPD, KSPD, NHPD, TRDU

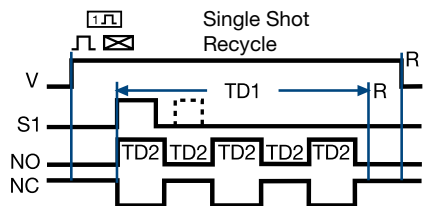

Single Shot/Lockout: (ProgramaCube® Function SL)

OPERATION: Upon application of input voltage and momentary or maintained closure of S1, the output (relay or solid state) energizes and TD1 single shot time delay begins. The output relay de-energizes at the end of TD1 and the TD2 lockout time delay begins. During TD2 (and TD1) closing switch S1 has no effect on the operation. After TD2 is complete, closing S1 starts another operation. If S1 is closed when input voltage is applied, the output energizes and the TD1 time delay begins.

RESET: Removing input voltage resets the time delays and the output and returns the cycle to the first delay.

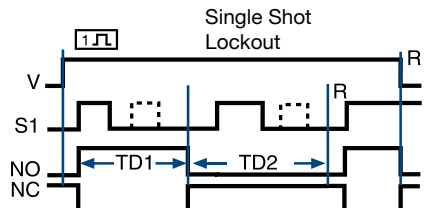

Interval/Delay On Make: (ProgramaCube® Function IM)

OPERATION: Upon application of input voltage, the output (relay or solid state) energizes and TD1 begins. At the end of TD1, the output de-energizes and TD2 begins. At the end of TD2, the output energizes.

RESET: Removing input voltage resets the time delays, output, and the sequence to the first delay. See: HRPD, KRPD, KSPD, NHPD, TRDU

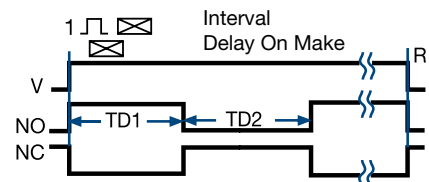

0232T
09.10

Timer Functions

Counting and Switching Functions

Leading edge flip-flop: (ProgramaCube® Function F)

OPERATION: Input voltage must be applied before and during operation. The operation begins with the output (relay or solid state) de-energized. Upon momentary or maintained closure (leading edge triggered) of the initiate switch S1, the time delay begins. At the end of the time delay, the output energizes and remains energized. Opening or re-closing S1 during timing has no affect. After the output transfers, the next closure of S1 starts a new operation. Each time an S1 closure is recognized, the time delay occurs and then the output transfers, ON to OFF, OFF to ON, ON to OFF. The first operation will occur if S1 is closed when input voltage is applied.

RESET: Removing input voltage resets the time delay and the output to the de-energized state.

Function can be applied to ProgramaCube Series: HRPS, KRPS, KSPS

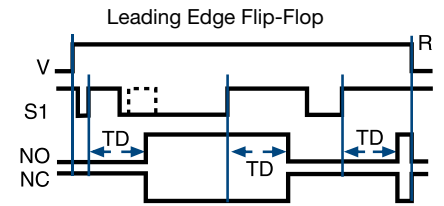

Alternating Relay (Trailing edge flip-flop): (ProgramaCube® Function FT)

OPERATION: Input voltage must be applied at all times for proper operation. The operation begins with the output (relay or solid state) de-energized. Closing S1 enables the next alternating operation. When S1 opens (trailing edge triggered), the time delay begins. At the end of the time delay, the output energizes and remains energized until S1 is (re-closed and) re-opened. Then the output relay de-energizes and remains until S1 opens again. Each time S1 opens the time delay occurs and the output transfers.

RESET: Removing input voltage resets the output and the time delay.

See: ARP, HRPS, KRPS

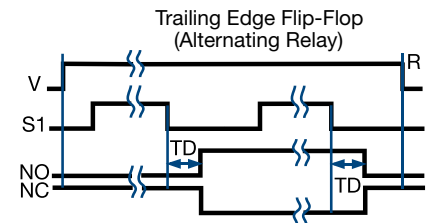

Counter with Pulsed Output: (ProgramaCube® Function C)

Function Limited to Switch Adjustable ProgramaCubes®

OPERATION: Input voltage must be applied before and during operation. Each time S1 is closed, a count is added. When the total number of S1 closures equals the total count selected on the unit, the output energizes. The output remains energized for the pulse duration specified for the product, and then de-energizes. If S1 is closed while the output is energized, a count is not added. If S1 is closed when input voltage is applied, a count is not added.

RESET: The unit automatically resets at the end of each operation. Removing input voltage resets the output, counter, and pulse delay.

See: HRPU, KSPU, NHPU

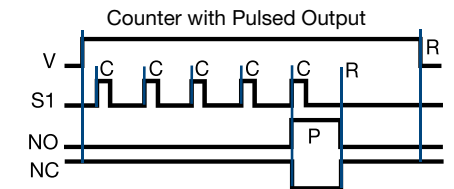

Counter with Interval Output: (ProgramaCube® Function CI)

Function Limited to Switch Adjustable ProgramaCubes®

OPERATION: Input voltage must be applied before and during operation. Each time S1 is closed, a count is added. When the total number of S1 closures equals the total count selected on the unit, the output energizes and the interval time delay begins. The output de-energizes at the end of the time delay. If S1 is closed during the time delay, a count is not added. If S1 is closed when input voltage is applied, a count is not added.

RESET: The counter is reset during the time delay, the unit automatically resets at the end of the interval time delay. Removing input voltage resets the output, counter, and time delay.

See: HRPU, HRV, HSPZ, KSPU, NHPU

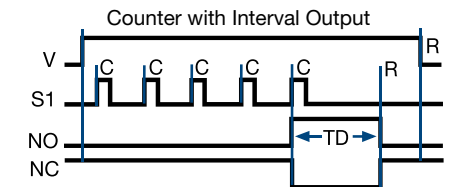

Legend

- V = Voltage
- R = Reset
- S1 = Initiate Switch
- TD, TD1, TD2 = Time Delay
- NO = Normally Open Contact
- NC = Normally Closed Contact
- C = Count
- P = Pulse Duration
- = Undefined Time