

MODEL PAX2A – 1/8 DIN ANALOG PANEL METER



- UNIVERSAL PROCESS, VOLTAGE, CURRENT, RESISTANCE AND TEMPERATURE INPUTS
- UNIVERSAL AC/DC POWER SUPPLY
- 6 / 9 DIGIT DUAL LINE/COLOR DISPLAY W/ 0.71" & 0.35" DIGITS
- PROGRAMMABLE UNITS DISPLAY
- VARIABLE CONTRAST AND INTENSITY DISPLAY
- UP TO 160 SAMPLES PER SECOND CONVERSION RATE
- BUILT-IN USB PROGRAMMING PORT ENABLING UNIT CONFIGURATION WITH CRIMSON PROGRAMMING SOFTWARE

DESCRIPTION

The PAX2A Analog Panel Meter offers many features and performance capabilities to suit a wide range of industrial applications. The PAX2A has a universal input to handle various input signals including DC Voltage/Current, Process, Resistance and Temperature. The optional plug-in output cards allow the opportunity to configure the meter for present applications, while providing easy upgrades for future needs. The PAX2A employs a dual line, tri color display with a large 0.71", tri color 6 digit top display line and a 0.35", 9 digit green bottom display line.

The meters provide a MAX and MIN reading memory with programmable capture time. The capture time is used to prevent detection of false max or min readings which may occur during start-up or unusual process events.

The signal totalizer (integrator) can be used to compute a time-input product. This can be used to provide a readout of totalized flow or calculate service intervals of motors, pumps, etc. The meters have up to four setpoint outputs, implemented on plug-in option cards. The plug-in cards provide dual FORM-C relays (5A), quad FORM-A (3A), or either quad sinking or quad sourcing open collector logic outputs. The setpoint alarms can be configured to suit a variety of control and alarm requirements.

Communication and bus capabilities are also available as option cards. These include RS232, RS485, DeviceNet, and Profibus-DP. The PAX2A can be programmed to utilize ModBus protocol. With ModBus, the user has access to most configuration parameters. Readout values and setpoint alarm values can be controlled through the bus. Additionally, the meters have a feature that allows a remote computer to directly control the outputs of the meter.

The PAX2A includes a built-in USB programming port that makes it possible to configure the meter using a Windows® based program, without any additional communication option cards. The configuration data can be saved to a file for later recall.

A linear DC output signal is available as an optional plug-in card. The card provides either 20 mA or 10 V signals. The output can be scaled independent of the input range and can track either the input, totalizer, max or min readings. Once the meters have been initially configured, the parameter list may be locked out from further modification in its entirety or partially locked allowing the setpoint values to remain accessible.

The meters have been specifically designed for harsh industrial environments. With NEMA 4X/IP65 sealed bezel and extensive testing of noise effects and CE requirements, the meter provides a tough yet reliable application solution.

SAFETY SUMMARY

All safety related regulations, local codes and instructions that appear in this literature or on equipment must be observed to ensure personal safety and to prevent damage to either the instrument or equipment connected to it. If equipment is used in a manner not specified by the manufacturer, the protection provided by the equipment may be impaired. Do not use this unit to directly command motors, valves, or other actuators not equipped with safeguards. To do so can be potentially harmful to persons or equipment in the event of a fault to the unit.

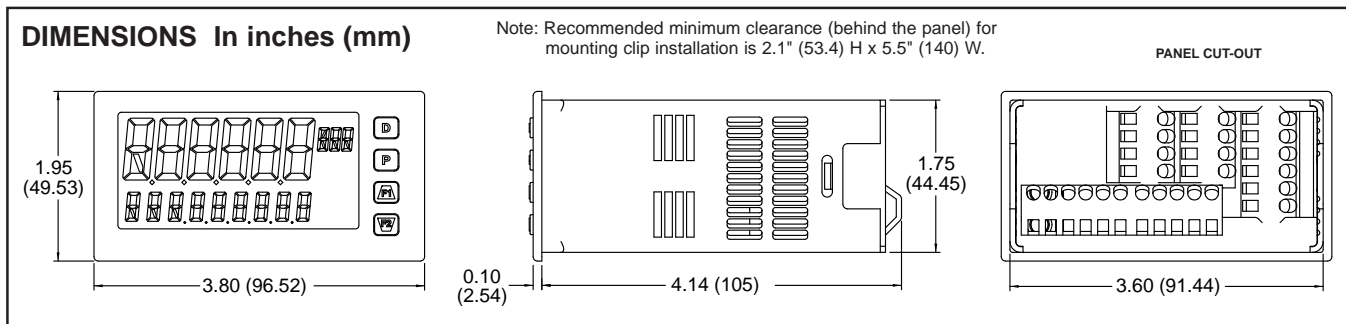
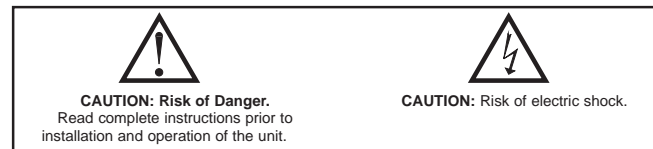

TABLE OF CONTENTS

Ordering Information	2	Wiring the Meter	7
General Meter Specifications	3	Reviewing the Front Buttons and Display	9
Optional Plug-In Cards	5	PAX2A Display Loops	10
Installing the Meter	6	Programming the PAX2A.	11
Setting the Jumpers	6	PAX2A Modbus Register Table	23
Installing the Plug-In Cards	7	Factory Service Operations	30

ORDERING INFORMATION

Meter Part Numbers

MODEL NO.	DESCRIPTION	PART NUMBER
PAX2A	Universal DC Analog Input Panel Meter	PAX2A000

Option Card and Accessories Part Numbers

TYPE	MODEL NO.	DESCRIPTION	PART NUMBER
Optional Plug-In Cards	PAXCDS	Dual Setpoint Relay Output Card	PAXCDS10
		Quad Setpoint Relay Output Card	PAXCDS20
		Quad Setpoint Sinking Open Collector Output Card	PAXCDS30
		Quad Setpoint Sourcing Open Collector Output Card	PAXCDS40
	PAXCDC	RS485 Serial Communications Card with Terminal Block	PAXCDC10
		Extended RS485 Serial Communications Card with Dual RJ11 Connector	PAXCDC1C
		RS232 Serial Communications Card with Terminal Block	PAXCDC20
		Extended RS232 Serial Communications Card with 9 Pin D Connector	PAXCDC2C
		DeviceNet Communications Card	PAXCDC30
		Profibus-DP Communications Card	PAXCDC50
PAXCDL	Analog Output Card	PAXCDL10	
Accessories	SFCRD ²	Crimson PC Configuration Software for Windows 98, ME, 2000 and XP	SFCRD200

Notes:

1. For Modbus communications use RS485 Communications Output Card and configure communication (TYPE) parameter for Modbus.
2. Crimson software is available for free download from <http://www.redlion.net/>

GENERAL METER SPECIFICATIONS

1. DISPLAY: Positive image LCD

Top Line - 6 digit, 0.71" (18 mm), with tri-color backlight (red, green or orange), display range: -199999 to 999999;
Bottom Line - 9 digit, 0.35" (8.9 mm), with green backlight, display range: -199,999,999 to 999,999,999

2. POWER:

AC Power: 50 to 250 VAC, 50/60 Hz, 14 VA
DC Power: 21.6 to 250 VDC, 8 W
Isolation: 2300 Vrms for 1 min. to all inputs and outputs.

3. ANNUNCIATORS: Backlight color: Red

1 - setpoint alarm 1
2 - setpoint alarm 2
3 - setpoint alarm 3
4 - setpoint alarm 4
Line 1 Units Label – programmable 3 digit units annunciator with tri-color backlight (red, green or orange)

4. KEYPAD: 2 programmable function keys, 4 keys total

5. A/D CONVERTER: 24 bit resolution

6. UPDATE RATES:

A/D conversion rate: programmable 5 to 160 readings/sec.

Step response:

Input Rate	5	10	20	40	80	160
Response Time*	600	400	200	100	50	30

* - msec. max. to within 99% of final readout value (digital filter disabled)

Display update rate: 1 to 20 updates/sec.

Setpoint output on/off delay time: 0 to 3275 sec.

Analog output update rate: 0 to 10 sec

Max./Min. capture delay time: 0 to 3275 sec.

7. DISPLAY MESSAGES:

“LOL” - Appears when measurement exceeds + signal range.
“ULUL” - Appears when measurement exceeds - signal range
“Short” - Appears when shorted sensor is detected. (RTD only)
“OPEN” - Appears when open sensor is detected.
“. . . .” - Appears when display values exceed + display range.
“-” - Appears when display values exceed - display range.

8. INPUT CAPABILITIES:

Current Input:

INPUT RANGE	ACCURACY (18 to 28°C)	ACCURACY (0 to 50°C)	IMPEDANCE/ COMPLIANCE	MAX CONT. OVERLOAD	* RESOLUTION
± 250 µADC	0.03% of rdg + µA	0.12% of rdg + µA	1.11 KΩ	mA	10nA
± 2.5 mADC	0.03% of rdg + µA	0.12% of rdg + µA	111 Ω	mA	0.1µA
± 25 mADC	0.03% of rdg + µA	0.12% of rdg + µA	11.1 Ω	mA	1µA
± 250 mADC	0.05% of rdg + µA	0.12% of rdg + µA	1.1 Ω	mA	10µA
± 2 ADC	0.5% of rdg + mA	0.7% of rdg + mA	0.1 Ω	mA	0.1mA

* Higher resolution can be achieved via input scaling.

Voltage Input:

INPUT RANGE	ACCURACY (18 to 28°C)	ACCURACY (0 to 50°C)	IMPEDANCE/ COMPLIANCE	MAX CONT. OVERLOAD	* RESOLUTION
± 250 mVDC	0.03% of rdg + µV	0.12% of rdg + µV	451 KΩ	V	10µV
± 2.0 VDC	0.03% of rdg + µV	0.12% of rdg + µV	451 KΩ	V	0.1mV
± 10 VDC	0.03% of rdg + µV	0.12% of rdg + µV	451 KΩ	V	1mV
± 25 VDC	0.03% of rdg + µV	0.12% of rdg + µV	451 KΩ	V	1mV
± 100 VDC	0.3% of rdg + mV	0.12% of rdg + mV	451 KΩ	V	10mV
± 200 VDC	0.3% of rdg + mV	0.12% of rdg + mV	451 KΩ	V	10mV

* Higher resolution can be achieved via input scaling.

Temperature Inputs:

READOUT:

Scale: F or C

Offset Range: -199,999 to 999,999

THERMOCOUPLE INPUTS:

Input Impedance: 20MΩ

Lead Resistance Effect: 0.03 % V/Ω

Max Continuous Overvoltage: 30 V

INPUT TYPE	RANGE	ACCURACY* (18 to 28 °C)	ACCURACY* (0 to 50 °C)	STANDARD	WIRE COLOR	
					ANSI	BS 1843
T	-200 to 400°C -270 to -200°C	1.2°C **	2.1°C	ITS-90	(+) blue (-) red	(+) white (-) blue
E	-200 to 871°C -270 to -200°C	1.0°C **	2.4°C	ITS-90	(+) purple (-) red	(+) brown (-) blue
J	-200 to 760°C	1.1°C	2.3°C	ITS-90	(+) white (-) red	(+) yellow (-) blue
K	-200 to 1372°C -270 to -200°C	1.3°C **	3.4°C	ITS-90	(+) yellow (-) red	(+) brown (-) blue
R	-50 to 1768°C	1.9°C	4.0°C	ITS-90	no standard	(+) white (-) blue
S	-50 to 1768°C	1.9°C	4.0°C	ITS-90	no standard	(+) white (-) blue
B	100 to 300°C 300 to 1820°C	3.9°C 2.8°C	5.7°C 4.4°C	ITS-90	no standard	no standard
N	-200 to 1300°C -270 to -200°C	1.3°C **	3.1°C	ITS-90	(+) orange (-) red	(+) orange (-) blue
C (W5/W26)	0 to 2315°C	1.9°C	6.1°C	ASTM E988-90***	no standard	no standard

* After 20 min. warm-up. Accuracy is specified in two ways: Accuracy over an 18 to 28°C and 15 to 75% RH environment; and Accuracy over a 0 to 50°C and 0 to 85% RH (non condensing) environment. Accuracy specified over the 0 to 50°C operating range includes meter tempco and ice point tracking effects. The specification includes the A/D conversion errors, linearization conformity, and thermocouple ice point compensation. Total system accuracy is the sum of meter and probe errors. Accuracy may be improved by field calibrating the meter readout at the temperature of interest.

** The accuracy over the interval -270 to -200°C is a function of temperature, ranging from 1°C at -200°C and degrading to 7°C at -270°C. Accuracy may be improved by field calibrating the meter readout at the temperature of interest.

*** These curves have been corrected to ITS-90.

RTD Inputs:

Type: 3 or 4 wire, 2 wire can be compensated for lead wire resistance

Excitation current: 100 ohm range: 165 µA

10 ohm range: 2.6 mA

Lead resistance: 100 ohm range: 10 ohm/lead max.

10 ohm range: 3 ohms/lead max.

Max. continuous overload: 30 V

INPUT TYPE	RANGE	ACCURACY* (18 to 28 °C)	ACCURACY* (0 to 50 °C)	STANDARD ***
100 ohm Pt alpha = .00385	-200 to 850°C	0.4°C	1.6°C	IEC 751
100 ohm Pt alpha = .00392	-200 to 850°C	0.4°C	1.6°C	no official standard
120 ohm Nickel alpha = .00672	-80 to 260°C	0.2°C	0.5°C	no official standard
10 ohm Copper alpha = .00427	-100 to 260°C	0.4°C	0.9°C	no official standard

9. EXCITATION POWER: Jumper selectable

Transmitter Power: +18 VDC @ 50 mA

Reference Voltage: + 2 VDC, +/- 2%

Compliance: 1KΩ load min (2 mA max)

Temperature Coefficient: 40 ppm/°C max.

Reference Current: 1.05 mADC, +/- 2%

Compliance: 10 KΩ load max.

Temperature Coefficient: 40 ppm/°C max.

10. USER INPUTS: Two programmable user inputs

Max. Continuous Input: 30 VDC

Isolation To Sensor Input Common: Not isolated.

Response Time: 12 msec. max.

Logic State: User programmable (USABLE) for sink/source (LO/HI) logic

INPUT STATE	SINKING INPUTS	SOURCING INPUTS
	20K Ω pull-up to +3.3V	20K Ω pull-down
Active	V _{IN} < 1.1 VDC	V _{IN} > 2.3 VDC
Inactive	V _{IN} > 2.3 VDC	V _{IN} < 1.1 VDC

11. TOTALIZER:

Time Base: second, minute, hour, or day
Batch: Can accumulate (gate) input display from a user input
Time Accuracy: 0.01% typical
Decimal Point: 0 to 0.0000
Scale Factor: 0.001 to 65.000
Low Signal Cut-out: -19,999 to 99,999
Total: 9 digits, display alternates between high order and low order readouts

12. CUSTOM LINEARIZATION:

Data Point Pairs: Selectable from 2 to 16
Display Range: -19,999 to 99,999
Decimal Point: 0 to 0.0000
Ice Point Compensation: user value (0.00 to 650.00 μ V/C)

13. MEMORY: Nonvolatile E²PROM memory retains all programmable parameters and display values.

14. ENVIRONMENTAL CONDITIONS:

Operating Temperature Range: 0 to 50 °C (0 to 45 °C with all three plug-in cards installed)
Storage Temperature Range: -40 to 60 °C
Operating and Storage Humidity: 0 to 85% max. RH non-condensing
Altitude: Up to 2000 meters

15. CERTIFICATIONS AND COMPLIANCES:

Consult factory for details.
Refer to EMC Installation Guidelines section of the bulletin for additional information.

16. CONNECTIONS: High compression cage-clamp terminal block

Wire Strip Length: 0.3" (7.5 mm)
Wire Gauge Capacity: One 14 AWG (2.55 mm) solid, two 18 AWG (1.02 mm) or four 20 AWG (0.61 mm)

17. CONSTRUCTION: This unit is rated for NEMA 4X/IP65 indoor use. IP20 Touch safe. Installation Category II, Pollution Degree 2. One piece bezel/case. Flame resistant. Synthetic rubber keypad. Panel gasket and mounting clip included.

18. WEIGHT: 8 oz. (226.8 g)

OPTIONAL PLUG-IN OUTPUT CARDS



WARNING: Disconnect all power to the unit before installing plug-in cards.

Adding Option Cards

The PAX2A meters can be fitted with up to three optional plug-in cards. The details for each plug-in card can be reviewed in the specification section below. Only one card from each function type can be installed at a time. The function types include Setpoint Alarms (PAXCDS), Communications (PAXCDC), and Analog Output (PAXCDL). The plug-in cards can be installed initially or at a later date.

COMMUNICATION CARDS (PAXCDC)

A variety of communication protocols are available for the PAX2A meter. Only one PAXCDC card can be installed at a time. *Note: For Modbus communications use RS485 Communications Output Card and configure communication (TYPE) parameter for Modbus.*

PAXCDC10 - RS485 Serial (Terminal) PAXCDC30 - DeviceNet
PAXCDC1C - RS485 Serial (Connector) PAXCDC50 - Profibus-DP
PAXCDC20 - RS232 Serial (Terminal)
PAXCDC2C - RS232 Serial (Connector)

SERIAL COMMUNICATIONS CARD

Type: RS485 or RS232
Isolation To Sensor & User Input Commons: 500 Vrms for 1 min.
Working Voltage: 50 V. Not Isolated from all other commons.
Data: 7/8 bits
Baud: 300 to 19,200
Parity: no, odd or even
Bus Address: Selectable 0 to 99, Max. 32 meters per line (RS485)
Transmit Delay: Selectable for 2 to 50 msec or 50 to 100 msec (RS485)

DEVICENET™ CARD

Compatibility: Group 2 Server Only, not UCMM capable
Baud Rates: 125 Kbaud, 250 Kbaud, and 500 Kbaud
Bus Interface: Phillips 82C250 or equivalent with MIS wiring protection per DeviceNet™ Volume I Section 10.2.2.
Node Isolation: Bus powered, isolated node
Host Isolation: 500 Vrms for 1 minute (50 V working) between DeviceNet™ and meter input common.

PROFIBUS-DP CARD

Fieldbus Type: Profibus-DP as per EN 50170, implemented with Siemens SPC3 ASIC
Conformance: PNO Certified Profibus-DP Slave Device
Baud Rates: Automatic baud rate detection in the range 9.6 Kbaud to 12 Mbaud
Station Address: 0 to 126, set by the master over the network. Address stored in non-volatile memory.
Connection: 9-pin Female D-Sub connector
Network Isolation: 500 Vrms for 1 minute (50 V working) between Profibus network and sensor and user input commons. Not isolated from all other commons.

PROGRAMMING SOFTWARE

The Crimson® software is a Windows® based program that allows configuration of the PAX® meter from a PC. Crimson offers standard drop-down menu commands, that make it easy to program the meter. The meter's program can then be saved in a PC file for future use. A PAX® serial plug-in card is required to program the meter using the software.

SETPOINT CARDS (PAXCDS)

The PAX2A meter has 4 available setpoint alarm output plug-in cards. Only one PAXCDS card can be installed at a time. (Logic state of the outputs can be reversed in the programming.) These plug-in cards include:

PAXCDS10 - Dual Relay, FORM-C, Normally open & closed
PAXCDS20 - Quad Relay, FORM-A, Normally open only
PAXCDS30 - Isolated quad sinking NPN open collector
PAXCDS40 - Isolated quad sourcing PNP open collector

DUAL RELAY CARD

Type: Two FORM-C relays
Isolation To Sensor & User Input Commons: 2000 Vrms for 1 min.
Working Voltage: 240 Vrms
Contact Rating:
One Relay Energized: 5 amps @ 120/240 VAC or 28 VDC (resistive load), 1/8 HP @ 120 VAC, inductive load
Total current with both relays energized not to exceed 5 amps
Life Expectancy: 100 K cycles min. at full load rating. External RC snubber extends relay life for operation with inductive loads

QUAD RELAY CARD

Type: Four FORM-A relays
Isolation To Sensor & User Input Commons: 2300 Vrms for 1 min.
Working Voltage: 250 Vrms
Contact Rating:
One Relay Energized: 3 amps @ 240 VAC or 30 VDC (resistive load), 1/10 HP @ 120 VAC, inductive load
Total current with all four relays energized not to exceed 4 amps
Life Expectancy: 100K cycles min. at full load rating. External RC snubber extends relay life for operation with inductive loads

QUAD SINKING OPEN COLLECTOR CARD

Type: Four isolated sinking NPN transistors.
Isolation To Sensor & User Input Commons: 500 Vrms for 1 min.
Working Voltage: 50 V. Not Isolated from all other commons.
Rating: 100 mA max @ $V_{SAT} = 0.7$ V max. $V_{MAX} = 30$ V

QUAD SOURCING OPEN COLLECTOR CARD

Type: Four isolated sourcing PNP transistors.
Isolation To Sensor & User Input Commons: 500 Vrms for 1 min.
Working Voltage: 50 V. Not Isolated from all other commons.
Rating: Internal supply: 18 VDC unregulated, 30 mA max. total
External supply: 30 VDC max., 100 mA max. each output

ALL FOUR SETPOINT CARDS

Response Time: 200 msec. max. to within 99% of final readout value (digital filter and internal zero correction disabled)
700 msec. max. (digital filter disabled, internal zero correction enabled)

LINEAR DC OUTPUT (PAXCDL)

Either a 0(4)-20 mA or 0-10 V retransmitted linear DC output is available from the analog output plug-in card. The programmable output low and high scaling can be based on various display values. Reverse slope output is possible by reversing the scaling point positions.

PAXCDL10 - Retransmitted Analog Output Card

ANALOG OUTPUT CARD

Types: 0 to 20 mA, 4 to 20 mA or 0 to 10 VDC
Isolation To Sensor & User Input Commons: 500 Vrms for 1 min.
Working Voltage: 50 V. Not Isolated from all other commons.
Accuracy: 0.17% of FS (18 to 28 °C); 0.4% of FS (0 to 50 °C)
Resolution: 1/3500
Compliance: 10 VDC: 10 K Ω load min., 20 mA: 500 Ω load max.
Powered: Self-powered
Update time: 200 msec. max. to within 99% of final output value (digital filter and internal zero correction disabled)
700 msec. max. (digital filter disabled, internal zero correction enabled)

1.0 INSTALLING THE METER

Installation

The PAX2A meets NEMA 4X/IP65 requirements when properly installed. The unit is intended to be mounted into an enclosed panel. Prepare the panel cutout to the dimensions shown. Remove the panel latch from the unit. Slide the panel gasket over the rear of the unit to the back of the bezel. The unit should be installed fully assembled. Insert the unit into the panel cutout.

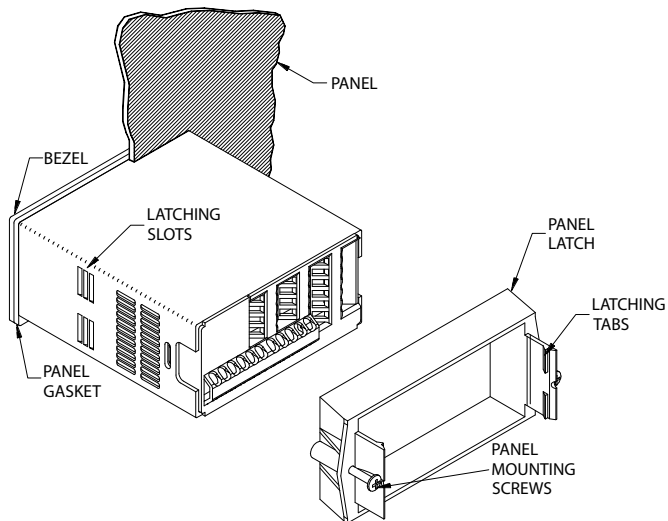

While holding the unit in place, push the panel latch over the rear of the unit so that the tabs of the panel latch engage in the slots on the case. The panel latch should be engaged in the farthest forward slot possible. To achieve a proper seal, tighten the latch screws evenly until the unit is snug in the panel (Torque to approximately 7 in-lbs [79N-cm]). Do not over-tighten the screws.

Installation Environment

The unit should be installed in a location that does not exceed the operating temperature and provides good air circulation. Placing the unit near devices that generate excessive heat should be avoided.

The bezel should only be cleaned with a soft cloth and neutral soap product. Do NOT use solvents. Continuous exposure to direct sunlight may accelerate the aging process of the bezel.

Do not use tools of any kind (screwdrivers, pens, pencils, etc.) to operate the keypad of the unit.

PANEL CUT-OUT

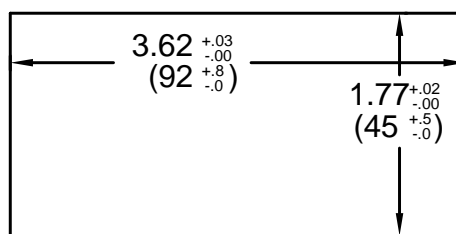

2.0 SETTING THE JUMPERS

The PAX2A meter has four jumpers that must be checked and/or changed prior to applying power. The following Jumper Selection Figures show an enlargement of the jumper area.

To access the jumpers, remove the meter base from the case by firmly squeezing and pulling back on the side rear finger tabs. This should lower the latch below the case slot (which is located just in front of the finger tabs). It is recommended to release the latch on one side, then start the other side latch.



Warning: Exposed line voltage exists on the circuit boards. Remove all power to the meter and load circuits before accessing inside of the meter.

INPUT RANGE JUMPERS

Configuring Voltage/Ohms

Two jumpers are used in configuring the meter for voltage/ohms. The first jumper, V/T, must be in the V position. The second jumper is used to select the proper voltage input range. (This jumper is also used to select the current input range.) Select a range that is high enough to accommodate the maximum signal input to avoid overloads. For proper operation, the input range selected in programming must match the jumper setting.

Current Input

For current input, only one jumper must be configured to select the current range. This jumper is shared with the voltage input range. Select the jumper position that is high enough to accommodate the maximum signal input level to avoid overloads.

Note: The position of the V/T jumper does not matter when the meter is in the current input mode.

Temperature Input

For temperature measurement the V/T jumper must be in the T position. For RTD sensors the RTD jumper must also be set.

Excitation Output Jumper

This jumper is used to select the excitation range for the application. If excitation is not being used, it is not necessary to check or move this jumper.

FRONT DISPLAY

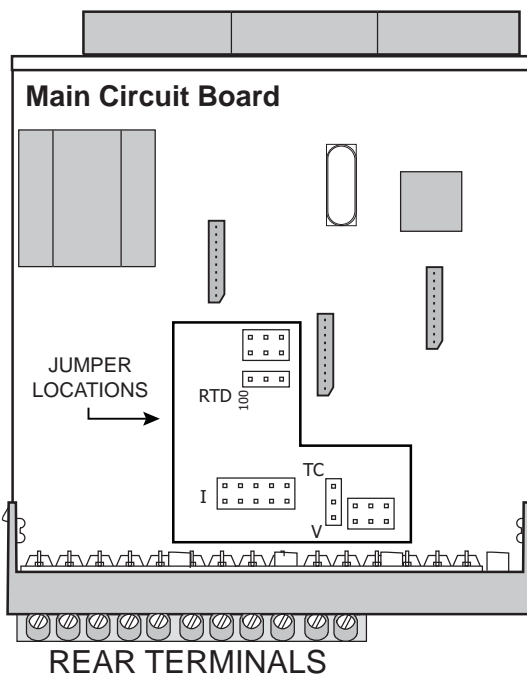

3.0 INSTALLING PLUG-IN CARDS

The plug-in cards are separately purchased optional cards that perform specific functions. These cards plug into the main circuit board of the meter. The plug-in cards have many unique functions when used with the PAX2A. The literature that comes with these cards should be discarded, unless it specifically states in the plug-in card literature that the information applies to the PAX2A.



CAUTION: The plug-in card and main circuit board contain static sensitive components. Before handling the cards, discharge static charges from your body by touching a grounded bare metal object. Ideally, handle the cards at a static controlled clean workstation. Also, only handle the cards by the edges. Dirt, oil or other contaminants that may contact the cards can adversely affect circuit operation.

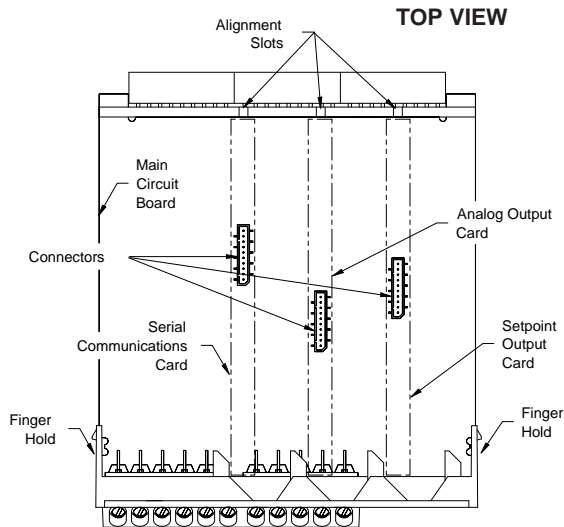

To Install:

1. With the case open, locate the plug-in card connector for the card type to be installed. The types are keyed by position with different main circuit board connector locations. When installing the card, hold the meter by the rear terminals and not by the front display board.*
2. Install the plug-in card by aligning the card terminals with the slot bay in the rear cover. Be sure the connector is fully engaged and the tab on the plug-in card rests in the alignment slot on the display board.
3. Slide the meter base back into the case. Be sure the rear cover latches fully into the case.
4. Apply the plug-in card label to the bottom side of the meter in the designated area. Do Not Cover the vents on the top surface of the meter. The surface of the case must be clean for the label to adhere properly.

* Quad Sourcing Open Collector Output Card Supply Select

If installing the Quad sourcing Plug-in Card (PAXCDS40), set the jumper for internal or external supply operation before continuing.

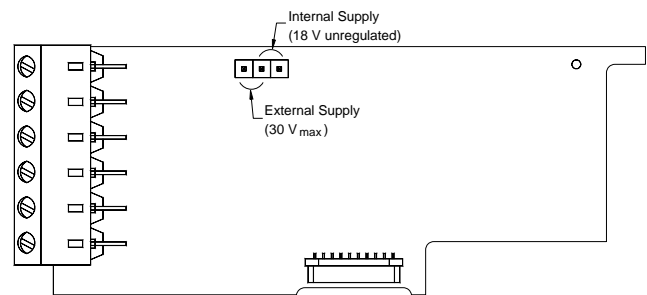

4.0 WIRING THE METER

WIRING OVERVIEW

Electrical connections are made via screw-clamp terminals located on the back of the meter. All conductors should conform to the meter's voltage and current ratings. All cabling should conform to appropriate standards of good installation, local codes and regulations. It is recommended that the power supplied to the meter (DC or AC) be protected by a fuse or circuit breaker.

When wiring the meter, compare the numbers embossed on the back of the meter case against those shown in wiring drawings for proper wire position. Strip the wire, leaving approximately 0.3" (7.5 mm) bare lead exposed (stranded wires should be tinned with solder.) Insert the lead under the correct screw-clamp terminal and tighten until the wire is secure. (Pull wire to verify tightness.) Each terminal can accept up to one #14 AWG (2.55 mm) wire, two #18 AWG (1.02 mm), or four #20 AWG (0.61 mm).

EMC INSTALLATION GUIDELINES

Although this meter is designed with a high degree of immunity to Electro-Magnetic Interference (EMI), proper installation and wiring methods must be followed to ensure compatibility in each application. The type of the electrical noise, source or coupling method into the meter may be different for various installations. The meter becomes more immune to EMI with fewer I/O connections. Cable length, routing, and shield termination are very important and can mean the difference between a successful or troublesome installation. Listed below are some EMC guidelines for successful installation in an industrial environment.

1. The meter should be mounted in a metal enclosure, which is properly connected to protective earth.
2. Use shielded (screened) cables for all Signal and Control inputs. The shield (screen) pigtail connection should be made as short as possible. The connection point for the shield depends somewhat upon the application. Listed below are the recommended methods of connecting the shield, in order of their effectiveness.
 - a. Connect the shield only at the panel where the unit is mounted to earth ground (protective earth).

- b. Connect the shield to earth ground at both ends of the cable, usually when the noise source frequency is above 1 MHz.
 - c. Connect the shield to common of the meter and leave the other end of the shield unconnected and insulated from earth ground.
3. Never run Signal or Control cables in the same conduit or raceway with AC power lines, conductors feeding motors, solenoids, SCR controls, and heaters, etc. The cables should be ran in metal conduit that is properly grounded. This is especially useful in applications where cable runs are long and portable two-way radios are used in close proximity or if the installation is near a commercial radio transmitter.
 4. Signal or Control cables within an enclosure should be routed as far as possible from contactors, control relays, transformers, and other noisy components.
 5. In extremely high EMI environments, the use of external EMI suppression devices, such as ferrite suppression cores, is effective. Install them on Signal and Control cables as close to the unit as possible. Loop the cable through the core several times or use multiple cores on each cable for additional protection. Install line filters on the power input cable to the unit to suppress power line interference. Install them near the power entry point of the enclosure. The following EMI suppression devices (or equivalent) are recommended:

Ferrite Suppression Cores for signal and control cables:

Fair-Rite # 0443167251 (RLC# FCOR0000)

TDK # ZCAT3035-1330A

Steward # 28B2029-0A0

Line Filters for input power cables:

Schaffner # FN610-1/07 (RLC# LFIL0000)

Schaffner # FN670-1.8/07

Corcom # 1 VR3

Note: Reference manufacturer's instructions when installing a line filter.

6. Long cable runs are more susceptible to EMI pickup than short cable runs. Therefore, keep cable runs as short as possible.
7. Switching of inductive loads produces high EMI. Use of snubbers across inductive loads suppresses EMI.
Snubber: RLC# SNUB0000.

4.1 POWER WIRING

AC Power

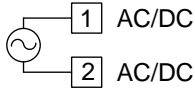

DC Power

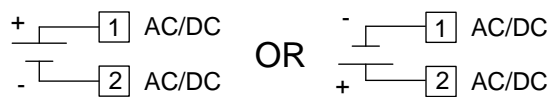

4.2 VOLTAGE/OHMS/CURRENT INPUT SIGNAL WIRING

Before connecting signal wires, the Input Range Jumper and Excitation Jumper should be verified for proper position.

Voltage Signal (self powered)

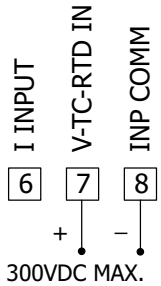

Process/Current Signal (self powered)

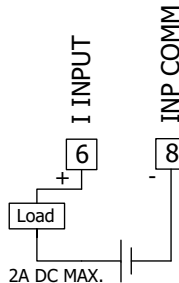

Process/Current Signal (2 wire requiring excitation)

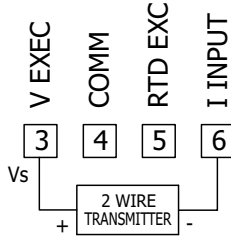

Current Signal (3 wire requiring excitation)

Terminal 3: +Volt supply
Terminal 6: +ADC (signal)
Terminal 8: -ADC (common)
Excitation Jumper: 18 V

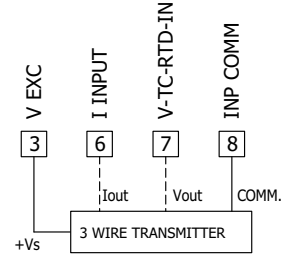

Voltage Signal (3 wire requiring excitation)

Terminal 3: +Volt supply
Terminal 7: +VDC (signal)
Terminal 8: -VDC (common)
Excitation Jumper: 18 V

Resistance Signal (2 wire requiring excitation)

Terminal 3: Jumper to terminal 7
Terminal 7: Resistance
Terminal 8: Resistance
Excitation Jumper: 1 mA REF.

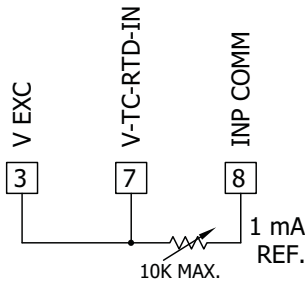

Potentiometer Signal (3 wire requiring excitation)

Terminal 3: High end of pot.
Terminal 7: Wiper
Terminal 8: Low end of pot.
Excitation Jumper: 2 V REF.
V/T Jumper: V
Input Range Jumper: 2 Volt
Module 1 Input Range: 2 Volt
Note: The Apply signal scaling style should be used because the signal will be in volts.

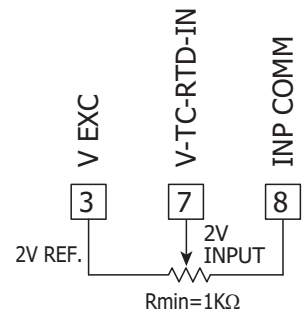

CAUTION: Sensor input common is NOT isolated from user input common. In order to preserve the safety of the meter application, the sensor input common must be suitably isolated from hazardous live earth referenced voltages; or input common must be at protective earth ground potential. If not, hazardous live voltage may be present at the User Inputs and User Input Common terminals. Appropriate considerations must then be given to the potential of the user input common with respect to earth common; and the common of the isolated plug-in cards with respect to input common.

4.3 TEMPERATURE INPUT SIGNAL WIRING

Before connecting signal wires, verify the V/T Jumper is in the T position.

Thermocouple

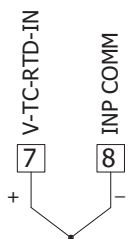

3-Wire RTD

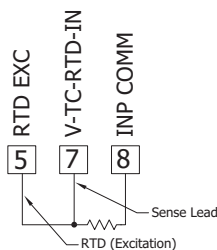

2-Wire RTD

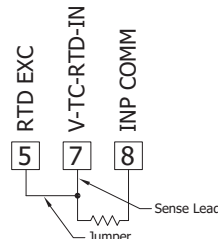

CAUTION: Sensor input common is NOT isolated from user input common. In order to preserve the safety of the meter application, the sensor input common must be suitably isolated from hazardous live earth referenced voltages; or input common must be at protective earth ground potential. If not, hazardous live voltage may be present at the User Inputs and User Input Common terminals. Appropriate considerations must then be given to the potential of the user input common with respect to earth common; and the common of the isolated plug-in cards with respect to input common.

4.4 USER INPUT WIRING

Before connecting the wires, the User Input Logic Jumper should be verified for proper position. If not using User Inputs, then skip this section. Only the appropriate User Input terminal has to be wired.

Sinking Logic

Terminals 9-10 } Connect external switching device between the
Terminal 8 } appropriate User Input terminal and User Comm.

When the $USrACt$ parameter is programmed to $L0$, the user inputs of the meter are internally pulled up to +3.3 V with 22 K Ω resistance. The input is active when it is pulled low (<1.1 V).

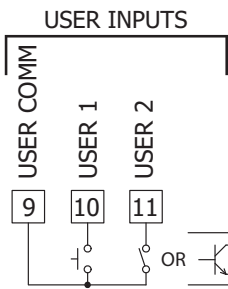

Sourcing Logic

Terminals 9-10: + VDC through external switching device

Terminal 8:

-VDC through external switching device

When the $USrACt$ parameter is programmed to $H1$, the user inputs of the meter are internally pulled down to 0 V with 20 K Ω resistance. The input is active when a voltage greater than 2.3 VDC is applied.

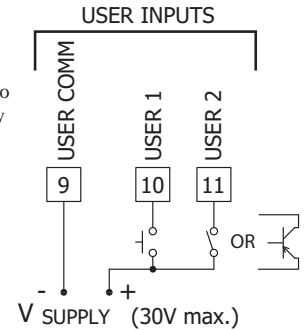

4.5 SETPOINT (ALARMS) WIRING

4.6 SERIAL COMMUNICATION WIRING

4.7 ANALOG OUTPUT WIRING

See appropriate plug-in card bulletin for details.

5.0 REVIEWING THE FRONT BUTTONS AND DISPLAY

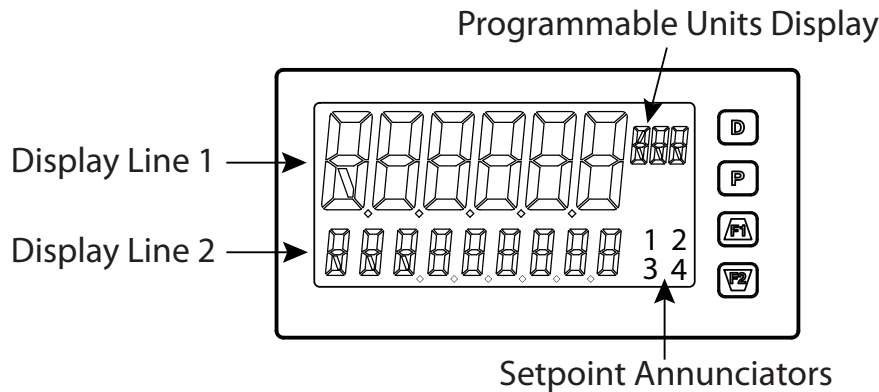

KEY DISPLAY MODE OPERATION

D	Index Line 2 through max/min/input/total readouts
P	Access the parameter and hidden display loops
F1	Function key 1; hold for 3 seconds for second function 1*
F2	Function key 2; hold for 3 seconds for second function 2*

PROGRAMMING MODE OPERATION

	Quick exit to display mode
	Access the programming parameter menus, store selected parameter and index to next parameter
	Increment selected parameter value
	Decrements selected parameter value

*Factory setting for F1 and F2 is no mode

The PAX2A display consists of a large, 6-digit upper display referred to as Line 1 and a smaller 9-digit lower display referred to as Line 2. The upper display (Line 1) can be configured to show a single value, i.e., the main input reading, Min, Max, or total values. The lower display (Line 2) can be used to display several selectable values including; input value, Min, Max, Total or setpoint values. For these values the Mnemonics is shown in the left most digits of Line 2.

PAX2A DISPLAY LOOPS

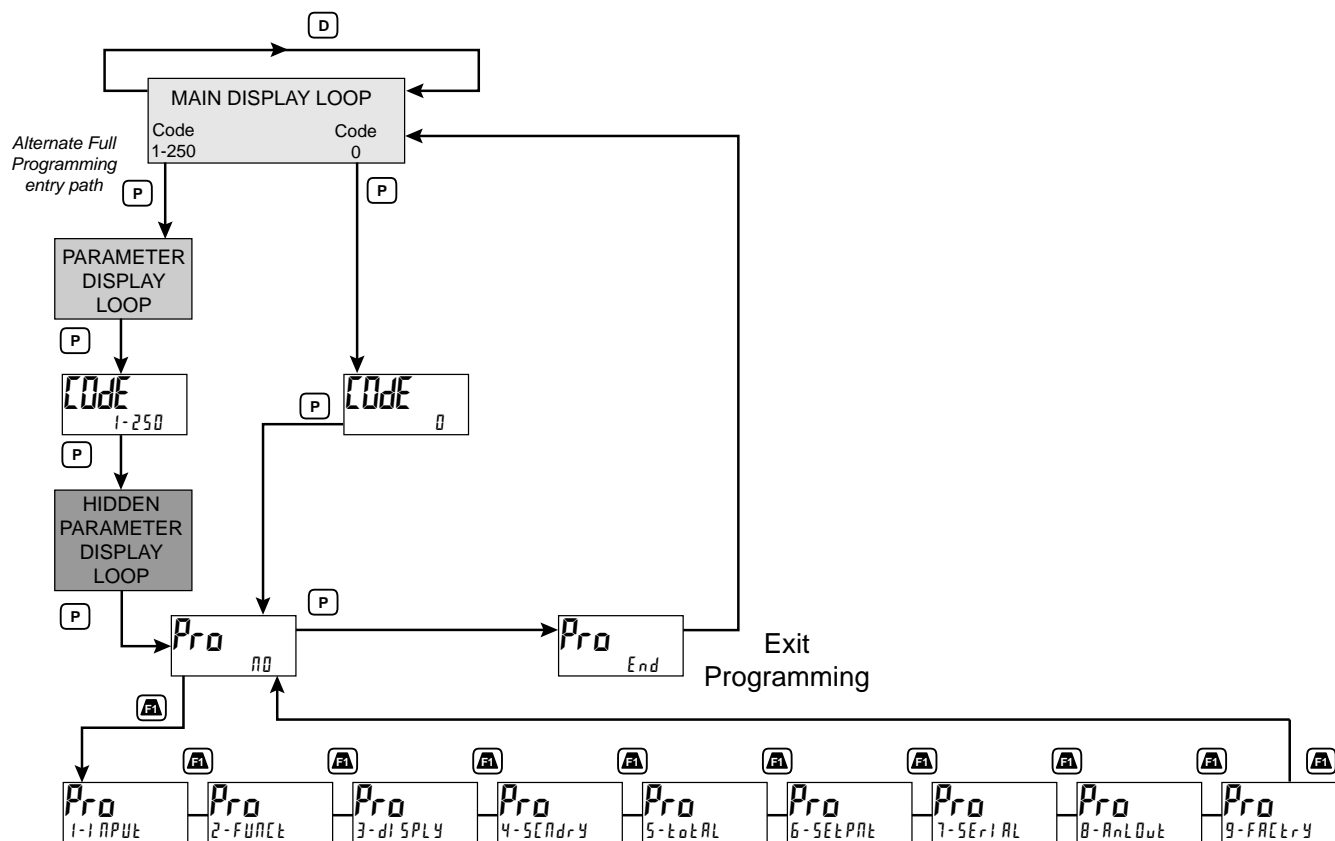

* Pressing "D" at any time exits back to the Main Display Loop.

PAX2A DISPLAY LOOPS

The PAX2A offers three display loops to allow users quick access to needed information. These display loops are available when the meter is in the normal display mode. By pressing the **D** key, the user can view parameters such as the total, Min, Max or the input in the Main Display Loop. Display selections are fully programmable and are viewed on the 9 digit line of the meter.

Pressing the **P** key with no security code (Code 0) will put the meter directly into the programming mode. When a security code is active (Code 1-255), pressing the **P** key will allow access to the Parameter Display Loop. This loop is where the parameters like setpoint values are normally put for general public access. Parameters in this loop can only be viewed/changed if enabled in the meter programming. After all the parameters in the Parameter Display Loop are viewed, an additional press of the **P** key will bring up the security code (Code 0). Access the Hidden Display Loop by entering the selected security code. In this loop all parameters can be changed. Combining the two parameter loops provides an area for parameters that require general access and/or protected or secure access depending on your application needs.

During programming of the meter you will need to select if a value is to be displayed or not. If the value is not required, select the lock mode (Lk). If you decide to display the value, you will need to assign it to a loop; **D** for the Main Display Loop, **P** for the Parameter Display Loop, and **HidE** for the Hidden Display Loop. In the case of the parameters, such as the setpoint values you will also need to decide if the value can only be read (rEd) or change/edit mode (Ent). The **UP** and **DN** key will increment or decrement the value when the edit mode is active. After the change, press the **P** key to save and move to the next value. Any values placed in the Hidden Parameter Loop can be changed as they are protected by the security code. While in the parameter display and hidden parameter loops, pressing the **D** key will return the meter to the main display.

There are selections in the programming that allow for the values to be reset. When the **P** key is pushed on a resettable display, the unit will display the value mnemonic and "00" (if Line 2 value was set for "P-Ent" or "d-Ent" in "3-dISPL"). Pressing the **UP** and **DN** keys will toggle between "00" and "4E5". Pressing the **P** key with "4E5" displayed will cause the reset action to be performed.

The **P**, Parameter key is used to scroll among the programmed Line 2 parameter values when at the main display or to step through the parameter loop and hidden parameter loop. It is used as the enter key when the meter is in the programming mode.

Numerical Value Entry

The **UP** and **DN** arrow keys are used to change the parameter values in any of the display loops, if the parameter is programmed for the change mode.

The **UP** and **DN** arrow keys will increment or decrement the parameter value. When the arrow key is pressed and held, the value automatically scrolls. The longer the arrow key is held the faster the value scrolls.

For large value changes, press and hold the **UP** or **DN** arrow key. While holding that arrow key, momentarily press the **D** key and the value scrolls by 1000's as the arrow key is held. Releasing the arrow key removes the 1000's scroll feature. The arrow keys can then be used to make small value changes as described above.

Main Display Loop

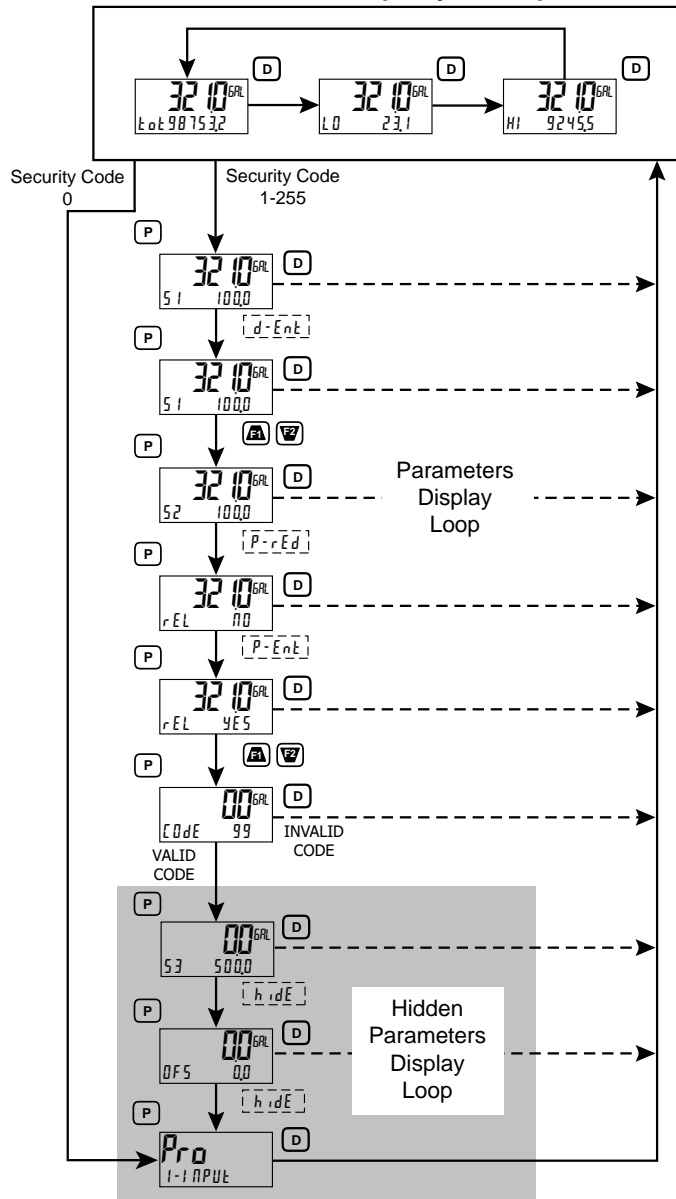

6.0 PROGRAMMING THE PAX2A

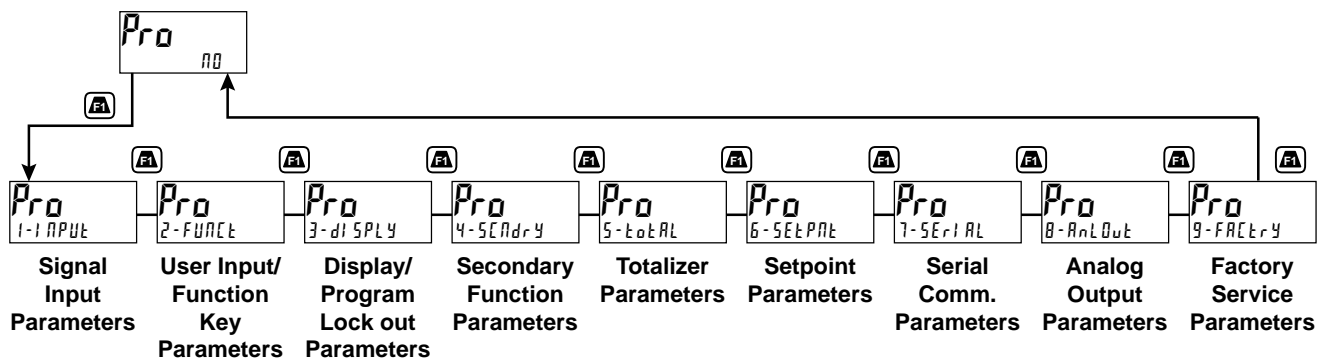

MODULE 1 - INPUT SETUP PARAMETERS (1-INPUT)

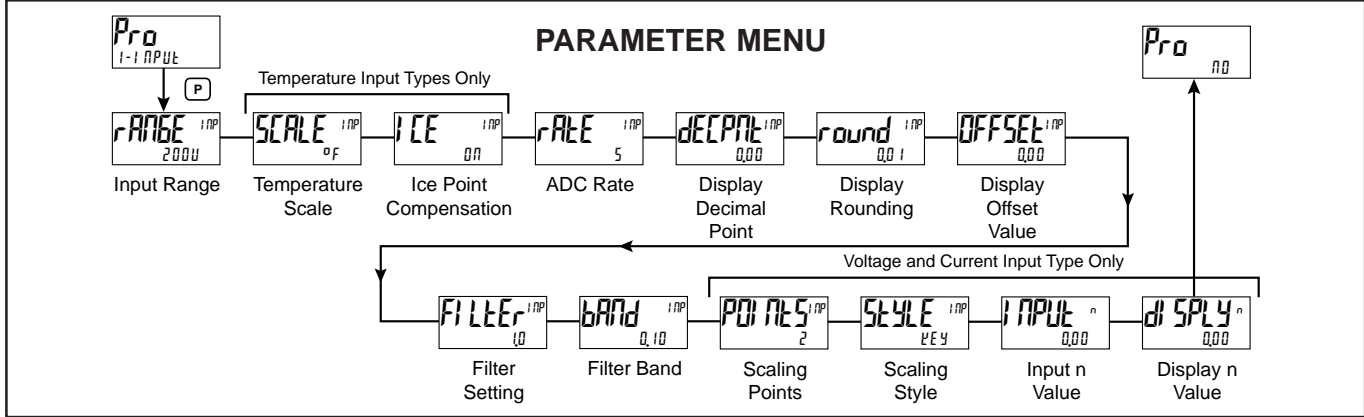

INPUT RANGE

RANGE 1NP	2000	1000	10000	100000	tc-t	tc-E
	tc-d	tc-L	tc-r	tc-5	tc-b	tc-n
	tc-C	r385	r392	r672	r427	250uA
	0.0025A	0.025A	0.25A	2A	0.25u	2u
	10u	25u	100u			

Select the desired input range.

ROUNDING INCREMENT

ROUND 1NP	1	2	5
	10	20	50
	100		

Rounding selections other than one, cause the Input Display to 'round' to the nearest rounding increment selected (ie. rounding of '5' causes 122 to round to 120 and 123 to round to 125). Rounding starts at the least significant digit of the Input Display. Remaining parameter entries (scaling point values, setpoint values, etc.) are not automatically adjusted to this display rounding selection.

TEMPERATURE SCALE

For TC and RTD Input Range Selection only.

SCALE 1NP	0F	0C
-----------	----	----

Select the temperature scale. This selection applies for Input, MAX, MIN, and TOT displays. If changed, those parameters that relate to the temperature scale should be checked. This selection is not available for custom sensor types.

ICE POINT COMPENSATION

For TC Input Range Selection only.

ICE 1NP	0N	OFF
---------	----	-----

This parameter turns the internal ice point compensation on or off. Normally, the ice point compensation is on. If using external compensation, set this parameter to off. In this case, use copper leads from the external compensation point to the meter.

ADC CONVERSION RATE (/SEC)

RATE 1NP	5	10	20	40	80	160
----------	---	----	----	----	----	-----

Select the ADC conversion rate (conversions per second). Temperature inputs can not be set higher than 20 updates per second. The selection does not affect the display update rate, however it does affect setpoint and analog output response time. The default factory setting of 5 is recommended for most applications. Selecting a fast update rate may cause the display to appear very unstable.

DECIMAL RESOLUTION

DECIMAL 1NP	0 to 0.00000 (curr/volt)
	0 to 0.0 (temp)

Select desired display resolution. The available selections are dependent on the Input Type selected (TYPE).

DISPLAY OFFSET

OFFSET 1NP	-199999 to 999999
------------	-------------------

The display can be corrected with an offset value. This can be used to compensate for probe errors, errors due to variances in probe placement or adjusting the readout to a reference thermometer. This value is automatically updated after a Zero Display to show how far the display is offset. A value of zero will remove the affects of offset.

DIGITAL FILTERING

FILTER 1NP	0.0 to 25.0 seconds
------------	---------------------

The input filter setting is a time constant expressed in tenths of a second. The filter settles to 99% of the final display value within approximately 3 time constants. This is an Adaptive Digital Filter which is designed to steady the Input Display reading. A value of '0' disables filtering.

FILTER BAND

BAND 1NP	0 to 250 display units
----------	------------------------

The digital filter will adapt to variations in the input signal. When the variation exceeds the input filter band value, the digital filter disengages. When the variation becomes less than the band value, the filter engages again. This allows for a stable readout, but permits the display to settle rapidly after a large process change. The value of the band is in display units, independent of the Display Decimal Point position. A band setting of '0' keeps the digital filter permanently engaged.

SCALING POINTS

POINTS 1NP	2 to 16
------------	---------

Linear - Scaling Points (2)

For linear processes, only 2 scaling points are necessary. It is recommended that the 2 scaling points be at opposite ends of the input signal being applied. The points do not have to be the signal limits. Display scaling will be linear

between and continue past the entered points up to the limits of the Input Signal Jumper position. Each scaling point has a coordinate-pair of Input Value (*I nPUT n*) and an associated desired Display Value (*dI SPLAY n*).

Nonlinear - Scaling Points (Greater than 2)

For non-linear processes, up to 16 scaling points may be used to provide a piece-wise linear approximation. (The greater the number of scaling points used, the greater the conformity accuracy.) The Input Display will be linear between scaling points that are sequential in program order. Each scaling point has a coordinate-pair of Input Value (*I nPUT n*) and an associated desired Display Value (*dI SPLAY n*). Data from tables or equations, or empirical data could be used to derive the required number of segments and data values for the coordinate pairs. In the Crimson software, several linearization equations are available.

SCALING STYLE

This parameter does not apply for thermocouple or RTD input ranges.



KEY key-in data
APPLY apply signal

If Input Values and corresponding Display Values are known, the Key-in (**KEY**) scaling style can be used. This allows scaling without the presence or changing of the input signal. If Input Values have to be derived from the actual input signal source or simulator, the Apply (**APPLY**) scaling style must be used.

INPUT VALUE FOR SCALING POINT 1



- 199999 to 999999

For Key-in (**KEY**), enter the known first Input Value by using the arrow keys. (The Input Range selection sets up the decimal location for the Input Value). For Apply (**APPLY**), the existing programmed value will appear. If this is acceptable, press the **P** key to save and continue to the next parameter. If the actual signal is required, apply signal, press **DN** key and the actual signal value will be displayed. Then press the **P** key to accept this value and continue to the next parameter.

DISPLAY VALUE FOR SCALING POINT 1



- 199999 to 999999

Enter the first coordinating Display Value by using the arrow keys. This is the same for **KEY** and **APPLY** scaling styles. The decimal point follows the **dECPtE** selection.

INPUT VALUE FOR SCALING POINT 2



- 199999 to 999999

For Key-in (**KEY**), enter the known second Input Value by using the arrow keys. For Apply (**APPLY**), adjust the signal source externally until the next desired Input Value appears. (Follow the same procedure if using more than 2 scaling points.) These bottom selections are not available for the TC or RTD Input ranges.

DISPLAY VALUE FOR SCALING POINT 2



- 199999 to 999999

Enter the second coordinating Display Value by using the arrow keys. This is the same for **KEY** and **APPLY** scaling styles. (Follow the same procedure if using more than 2 scaling points.)

ENABLE SCALE LIST



NO YES

When enabled, a second list of scaling points is active in the selected parameter list for List A and List B.

MODULE 2 - USER INPUT/FUNCTION KEY PARAMETERS (2-FUNCT)

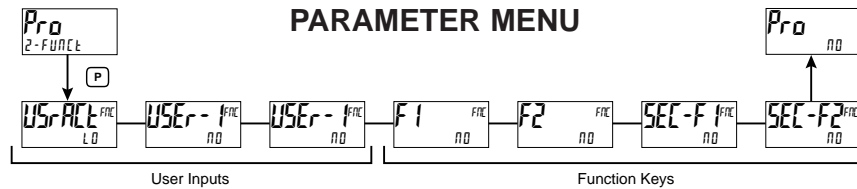

The two user inputs are individually programmable to perform specific meter control functions. While in the Display Mode or Program Mode, the function is executed the instant the user input transitions to the active state. The front panel function keys, F1 and F2, are also individually programmable to perform specific meter control functions. While in the Display Mode, the primary function is executed the instant the key is pressed. Holding the function key for three seconds executes a secondary function. It is possible to program a secondary function without a primary function.

In most cases, if more than one user input and/or function key is programmed for the same function, the maintained (level trigger) actions will be performed while at least one of those user inputs or function keys are activated. The momentary (edge trigger) actions will be performed every time any of those user inputs or function keys transition to the active state.

Note: In the following explanations, not all selections are available for both user inputs and front panel function keys. Displays are shown with each selection. Those selections showing both displays are available for both. If a display is not shown, it is not available for that selection. *USER-1* will represent both user inputs. *F1* will represent both function keys.

USER INPUT ACTIVE STATE



Select the desired active state for the User Inputs.

USER INPUT x



- NO SYnc d-HI d-LEU r-4
- PLOC bAR r-HI CoLoR r-34
- rEL d-toE d-Lo LISt r-234
- d-rEL r-toE1 r-Lo r-1 r-ALL
- d-HLd r-toE2 r-HL r-2 Pr int
- A-HLd E-toE dI SP r-3

NO FUNCTION



No function is performed if activated. This is the factory setting for all user inputs and function keys. No function can be selected without affecting basic startup.

PROGRAMMING MODE LOCK-OUT



Programming Mode is locked-out, as long as activated (maintained action). A security code can be configured to allow programming access during lock-out.

ZERO (TARE) DISPLAY



The Zero (Tare) Display provides a way to zero the Input Display value at various input levels, causing future Display readings to be offset. This function is useful in weighing applications where the container or material on the scale should not be included in the next measurement value. When activated (momentary action), *rESEt* flashes and the Display is set to zero. At the same time, the Display value (that was on the display before the Zero Display) is subtracted from the Display Offset Value and is automatically stored as the new Display Offset Value. If another Zero (tare) Display is performed, the display will again change to zero and the Display reading will shift accordingly.

RELATIVE/ABSOLUTE DISPLAY



This function will switch the Input Display between Relative and Absolute. The Relative is a net value that includes the Display Offset Value. The Input Display will normally show the Relative unless switched by this function. Regardless of the display selected, all meter functions continue to operate based on relative values. The Absolute is a gross value (based on Module 1 DSP and INP entries) without the Display Offset Value. The Absolute display is selected as long as the user input is activated (maintained action) or at the transition of the function key (momentary action). When the user input is released, or the function key is pressed again, the input display switches back to Relative display. (*Rb5*) or (*rEL*) is momentarily displayed at transition to indicate which display is active.

HOLD DISPLAY

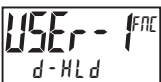

The shown display is held but all other meter functions continue as long as activated (maintained action).

HOLD ALL FUNCTIONS



The meter disables processing the input, holds all display contents, and locks the state of all outputs as long as activated (maintained action). The serial port continues data transfer.

SYNCHRONIZE METER READING



The meter suspends all functions as long as activated (maintained action). When the user input is released, the meter synchronizes the restart of the A/D with other processes or timing events.

STORE BATCH READING IN TOTALIZER



The Input Display value is one time added (batched) to the Totalizer at transition to activate (momentary action) and Line 2 flashes *bAtch*. The Totalizer retains a running sum of each batch operation until the Totalizer is reset. When this function is selected, the normal operation of the Totalizer is overridden.

SELECT TOTALIZER DISPLAY



The Totalizer display is selected as long as activated (maintained action). When the user input is released, the Input Display is returned. The **D** key overrides the active user input. The Totalizer continues to function including associated outputs independent of being displayed.

RESET TOTALIZER



When activated (momentary action), *rESEt* flashes and the Totalizer resets to zero. The Totalizer then continues to operate as it is configured. This selection functions independent of the selected display.

RESET AND ENABLE TOTALIZER



When activated (momentary action), *rESEt* flashes and the Totalizer resets to zero. The Totalizer continues to operate while active (maintained action). When the user input is released, the Totalizer stops and holds its value. This selection functions independent of the selected display.

ENABLE TOTALIZER



The Totalizer continues to operate while active (maintained action). When the user input is released, the Totalizer stops and holds its value. This selection functions independent of the selected display.

SELECT MAXIMUM DISPLAY

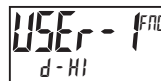

The Maximum display appears on Line 2 as long as activated (maintained). The *HI* annunciator identifies the Maximum display value. When the user input is released, the Maximum display is removed from Line 2. The **D** or **P** keys override the active user input. The Maximum continues to function independent of being displayed.

RESET MAXIMUM DISPLAY

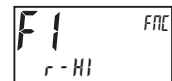
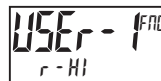

When activated (momentary action), *rESEt* flashes and the Maximum resets to the present Input Display value. The Maximum function then continues from that value. This selection functions independent of the selected display.

SELECT MINIMUM DISPLAY



The Minimum display appears on Line 2 as long as activated (maintained). The *Lo* annunciator identifies the Minimum display value. When the user input is released, the Minimum display is removed from Line 2. The **D** or **P** keys override the active user input. The Minimum continues to function independent of being displayed.

RESET MINIMUM DISPLAY

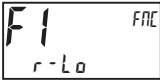

When activated (momentary action), *rESEt* flashes and the Minimum resets to the present Input Display value. The Minimum function then continues from that value. This selection functions independent of the selected display.

RESET MAXIMUM AND MINIMUM DISPLAY

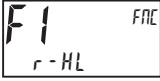

When activated (momentary action), *rESEt* flashes and the Maximum and Minimum readings are set to the present Input Display value. The Maximum and Minimum function then continues from that value. This selection functions independent of the selected display.

DISPLAY SELECT



When activated (momentary action), Line 2 advances to the next display that is not locked out from the Display Mode.

ADJUST DISPLAY INTENSITY



When activated (momentary action), the display intensity changes to the next intensity level (of 5). The intensity level, when changed via the User Input/Function Key, is not retained at power-down, unless Quick Programming or Full Programming mode is entered and exited. The meter will power-up at the last saved intensity level.

CHANGE DISPLAY COLOR



When activated (momentary action), Line 1 will change color.

SELECT PARAMETER LIST



Two lists of input scaling points and setpoint values (including band and deviation) are available. The two lists are named *LISt-A* and *LISt-B*. If a user input is used to select the list then *LISt-A* is selected when the user input is not active and *LISt-B* is selected when the user input is active (maintained action). If a front panel key is used to select the list then the list will toggle for each key press (momentary action). The display will only indicate which list is active when the list is changed. To program the values for *LISt-A* and *LISt-B*, first complete the programming of all the parameters. Exit programming and switch to the other list. Re-enter programming and enter the desired values for the input scaling points and *SP1*, *SP2*, *SP3*, and *SP4*, if used. If any other parameters are changed then the other list values must be reprogrammed.

SETPOINT SELECTIONS

The following selections are functional only with a Setpoint plug-in card installed.

- LISt* - Select main or alternate setpoints
- r-1* - Reset Setpoint 1 (Alarm 1)
- r-2* - Reset Setpoint 2 (Alarm 2)
- r-3* - Reset Setpoint 3 (Alarm 3)
- r-4* - Reset Setpoint 4 (Alarm 4)
- r-34* - Reset Setpoint 3 & 4 (Alarm 3 & 4)
- r-234* - Reset Setpoint 2, 3 & 4 (Alarm 2, 3 & 4)
- r-ALL* - Reset All Setpoints (Alarms 1-4)

PRINT REQUEST

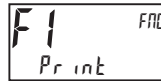

The meter issues a block print through the serial port when activated, and the serial type is set to *rLL*. The data transmitted during a print request and the serial type is programmed in Module 7. If the user input is still active after the transmission is complete (about 100 msec), an additional transmission occurs. As long as the user input is held active, continuous transmissions occur.

MODULE 3 - DISPLAY PARAMETERS (3-DISPLY)

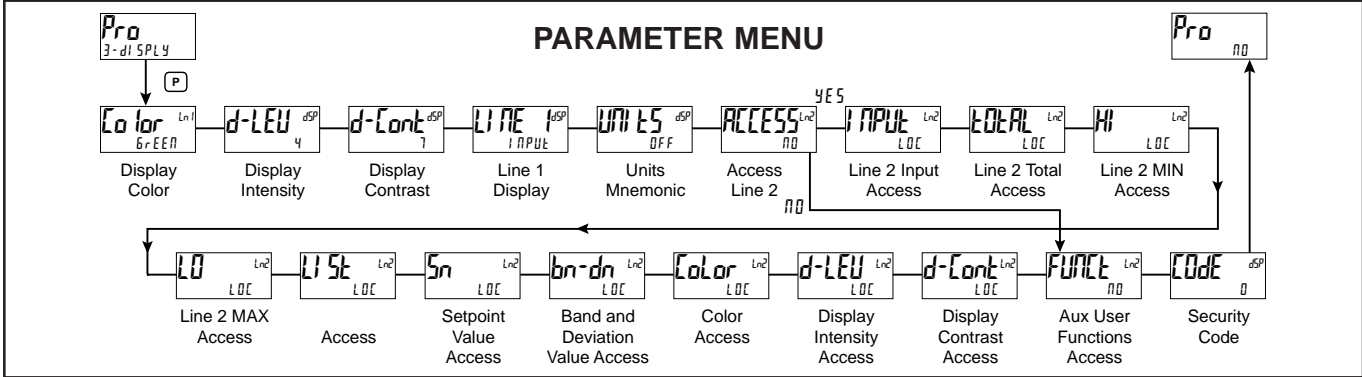

Module 3 is the programming of the Main Display loop, Parameter display loop (quick programming) access or lock-out, Hidden parameter loop, and full programming lock-out. The large upper display line value is configured by the "LINE" parameter. The Units mnemonic can be used to assign user units or a custom display mnemonic to the upper display value. When in the main display loop, the available Line 2 displays (items configured for d-rEd or d-Ent) can be consecutively read on lower display by repeatedly pressing the **D** key. A left justified 3 character mnemonic indicates which parameter value is being shown on the lower display. When in the main display loop the User keys **F1** and **F2** function as programmed in Module 2.

The Parameter display loop items can be accessed by pressing the **P** key. To edit a main display line item, that is configured as d-Ent, the **P** key is pushed and the unit enters a parameter edit mode in which the **UP/F1** and **DN/F2** key increments or decrements the value. "Full" Programming Mode permits all parameters to be viewed and modified. This Programming Mode can be locked with a security code and/or user input.

LINE1 DISPLAY COLOR



Enter the desired Line 1 display color.

DISPLAY INTENSITY LEVEL

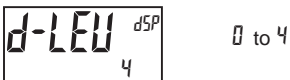

Enter the desired Display Intensity Level (0-4) by using the arrow keys. The display will actively dim or brighten as the levels are changed. This parameter also appears in Quick Programming Mode when enabled.

DISPLAY CONTRAST LEVEL



Enter the desired Display Contrast Level (0-15) by using the arrow keys. The display contrast / viewing angle will actively move up or down as the levels are changed. This parameter also appears in Quick Programming Mode when enabled.

LINE 1 DISPLAY

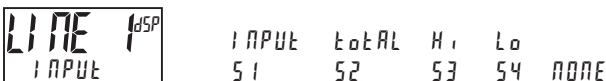

Select the value to be assigned to the primary or top line of the meter display.

UNITS MNEMONIC



This parameter activates the Units Indicator on the display. There are two methods of selecting the Indicator. List will present a group of Units preprogrammed into the meter. Segments allows the user to choose which of the segments should light, however they can only be programmed via Crimson programming software.

LINE2 MAIN, SECONDARY & HIDDEN DISPLAY LOOP ACCESSIBLE ITEMS

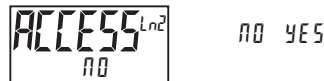

Select **YES** to program the display Line 2 accessible values. The default setting of **NO** bypasses the programming of these values to shorten the module.

All of the individual Line 2 settings are retained.

The following values can be made accessible on Line 2 of the Main Display (**D** key), Parameter (**P** key) and Hidden (**P** key following code entry) loops.

Each of the following parameters can be configured for one of the following settings. Not all selections are available for each parameter.

SELECTION	DESCRIPTION
LOC	Not visible on display line
d-rEd	Visible in main Display loop, but not changeable (resettable)
d-Ent	Visible and changeable (or resettable) in main Display loop
P-rEd	Visible (read only) in Parameter display loop
P-Ent	Visible and changeable in Parameter display loop
HiDE	Visible and changeable in Hidden Programming mode

LINE2 INPUT, TOTAL, MIN & MAX ACCESS



When configured for d-Ent or P-Ent, the value is resettable. To reset the value, push the **P** key when viewing the value. "r5t" will be displayed at which point the, up key can be pressed so that the display shows r5-YES. Pressing the **P** key again will initiate the reset action.

LINE2 PARAMETER LIST A/B ACCESS



See User Functions "Select Parameter List" for a description of the list function. The Line 2 Parameter List provides a means of setting or viewing the active parameter list.

LINE2 SETPOINTS ACCESS



When configured for *d-ENt*, the **P** key must be pushed to select the item for change before the **UP/F1** and **DN/F2** keys will increment or decrement the value.

LINE2 PARAMETER & HIDDEN DISPLAY LOOP ACCESSIBLE ITEMS

The following values can be made accessible on Line 2 in the Parameter (**P** key) and Hidden (**P** key following code entry) loops. They cannot be made accessible in the Main Display loop (**D** key). They can be configured for the following settings:

LINE 1 DISPLAY COLOR ACCESS



DISPLAY INTENSITY ACCESS



DISPLAY CONTRAST ACCESS



LINE2 USER FUNCTIONS ACCESSIBLE ITEMS



YES NO

Select **YES** to display the following list of User functions that can be made available at the end of the Secondary or Hidden display loops. The more critical and frequently used Functions should be first assigned to the User Inputs and User Function keys. If more functions are needed than what can be obtained with User Inputs, this feature will provide a means to provide that access. Refer to module 2, *2-FAC* for a description of the function.

rEL bRE r-tot r-H1 r-Lo
 r-HL r-1 r-2 r-3 r-4
 r-34 r-234 r-ALL Pr int

PROGRAMMING SECURITY CODE



000 to 250

The Security Code determines the programming mode and the accessibility of programming parameters. This code can be used along with the Program Mode Lock-out (*PLBL*) in the User Input Function parameter (Module 1).

Two programming modes are available. Full Programming mode allows all parameters to be viewed and modified. Quick Programming mode permits only the Setpoint values to be modified, but allows direct access to these values without having to enter Full Programming mode.

Programming a Security Code other than 0, requires this code to be entered at the *CODE* prompt in order to access Full Programming mode. Depending on the code value, Quick Programming may be accessible before the *CODE* prompt appears (see chart).

SECURITY CODE	USER INPUT CONFIGURED	USER INPUT STATE	WHEN KEY IS PRESSED	FULL PROGRAMMING MODE ACCESS
0	not <i>PLBL</i>	_____	Full Programming	Immediate Access
>0	not <i>PLBL</i>	_____	Quick Programming w/Display Intensity	After Quick Programming with correct code # at <i>CODE</i> prompt.
>0	<i>PLBL</i>	Active	Quick Programming w/Display Intensity	After Quick Programming with correct code # at <i>CODE</i> prompt.
>0	<i>PLBL</i>	Not Active	Full Programming	Immediate Access
0	<i>PLBL</i>	Active	Quick Programming	No Access
0	<i>PLBL</i>	Not Active	Full Programming	Immediate Access

Throughout this document, Programming Mode (without Quick in front) always refers to "Full" Programming (all meter parameters are accessible).

MODULE 4 - SECONDARY FUNCTION PARAMETERS (4-5Cndry)

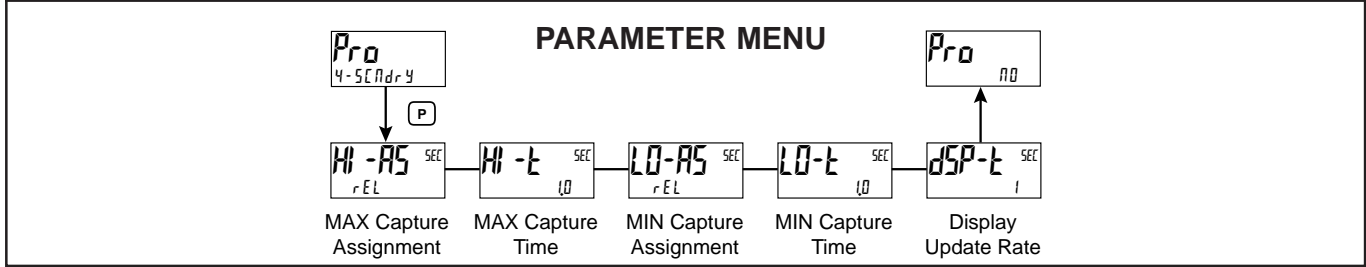

MAX CAPTURE ASSIGNMENT



rEL Ab5

Select the desired parameter that will be assigned to the Max Capture.

MAX CAPTURE DELAY TIME

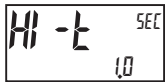

0.0 to 3275.0 seconds

When the Input Display is above the present MAX value for the entered delay time, the meter will capture that display value as the new MAX reading. A delay time helps to avoid false captures of sudden short spikes.

MIN CAPTURE ASSIGNMENT



rEL Ab5

Select the desired parameter that will be assigned to the Min Capture.

MIN CAPTURE TIME



0.0 to 3275.0 seconds

When the Input Display is below the present MIN value for the entered delay time, the meter will capture that display value as the new MIN reading. A delay time helps to avoid false captures of sudden short spikes.

DISPLAY UPDATE RATE



1 2 5 10 20

This parameter configures the display update rate. It does not affect the response time of the setpoint output or analog output option cards.

MODULE 5 - TOTALIZER (INTEGRATOR) PARAMETERS (5-tOTAL)

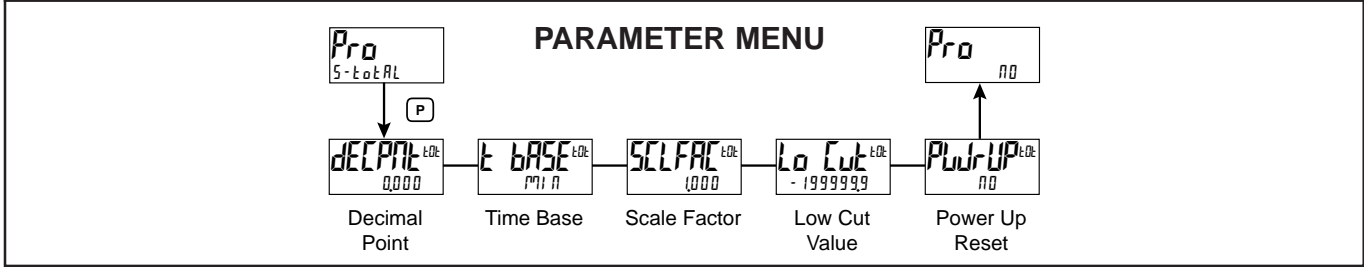

The totalizer accumulates (integrates) the Input Display value using one of two modes. The first is using a time base. This can be used to compute a time temperature product. The second is through a user input or function key programmed for Batch (one time add on demand). This can be used to provide a readout of temperature integration, useful in curing and sterilization applications. If the Totalizer is not needed, its display can be locked-out and this module can be skipped during programming.

TOTALIZER DECIMAL POINT



For most applications, this matches the Input Display Decimal Point (dECPtE). If a different location is desired, refer to Totalizer Scale Factor.

TOTALIZER TIME BASE

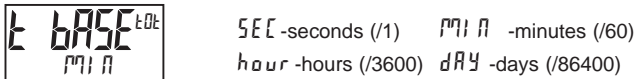

This is the time base used in Totalizer accumulations. If the Totalizer is being accumulated through a user input programmed for Batch, then this parameter does not apply.

TOTALIZER SCALE FACTOR

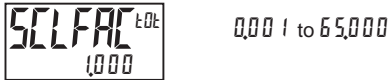

For most applications, the Totalizer reflects the same decimal point location and engineering units as the Input Display. In these cases, the Totalizer Scale Factor is 1.000. The Totalizer Scale Factor can be used to scale the Totalizer to a value that is different than the Input Display. Common possibilities are:

1. Changing decimal point location (example tenths to whole)
2. Average over a controlled time frame.

Details on calculating the scale factor are shown later.

If the Totalizer is being accumulated through a user input programmed for Batch, then this parameter does not apply.

TOTALIZER LOW CUT VALUE

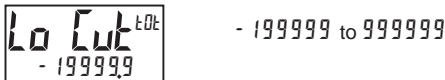

A low cut value disables Totalizer when the Input Display value falls below the value programmed.

TOTALIZER POWER UP RESET

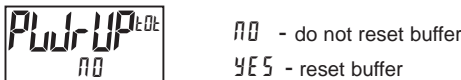

The Totalizer can be reset to zero on each meter power-up by setting this parameter to reset.

TOTALIZER BATCHING

The Totalizer Time Base and scale factor are overridden when a user input or function key is programmed for store batch (bAt). In this mode, when the user input or function key is activated, the Input Display reading is one time added to the Totalizer (batch). The Totalizer retains a running sum of each batch operation until the Totalizer is reset. This is useful in weighing operations, when the value to be added is not based on time but after a filling event.

TOTALIZER USING TIME BASE

Totalizer accumulates as defined by:

$$\frac{\text{Input Display} \times \text{Totalizer Scale Factor}}{\text{Totalizer Time Base}}$$

Where:

Input Display - the present input reading

Totalizer Scale Factor - 0.001 to 65.000

Totalizer Time Base - (the division factor of tBASE)

Example: The input reading is at a constant rate of 10.0 gallons per minute. The Totalizer is used to determine how many gallons in tenths has flowed. Because the Input Display and Totalizer are both in tenths of gallons, the Totalizer Scale Factor is 1. With gallons per minute, the Totalizer Time Base is minutes (60). By placing these values in the equation, the Totalizer will accumulate every second as follows:

$$\frac{10.0 \times 1.000}{60} = 0.1667 \text{ gallon accumulates each second}$$

This results in:

10.0 gallons accumulates each minute

600.0 gallons accumulates each hour

TOTALIZER SCALE FACTOR CALCULATION EXAMPLES

1. When changing the Totalizer Decimal Point (dECPtE) location from the Input Display Decimal Point (dECPtE), the required Totalizer Scale Factor is multiplied by a power of ten.

Example:

Input (dECPtE) = 0

Input (dECPtE) = 0.0

Input (dECPtE) = 0.00

Totalizer dECPtE	Scale Factor
0.0	10
0	1
x10	0.1
x100	0.01
x1000	0.001

Totalizer dECPtE	Scale Factor
0.00	10
0.0	1
0	0.1
x10	0.01
x100	0.001

Totalizer dECPtE	Scale Factor
0.000	10
0.00	1
0.0	0.1
0	0.01
x10	0.001

(x = Totalizer display is round by tens or hundreds)

2. To obtain an average reading within a controlled time frame, the selected Totalizer Time Base is divided by the given time period expressed in the same timing units.

Example: Average temperature per hour in a 4 hour period, the scale factor would be 0.250. To achieve a controlled time frame, connect an external timer to a user input programmed for r-tDE. The timer will control the start (reset) and the stopping (hold) of the totalizer.

MODULE 6 - SETPOINT OUTPUT PARAMETERS (6-SETPNT)

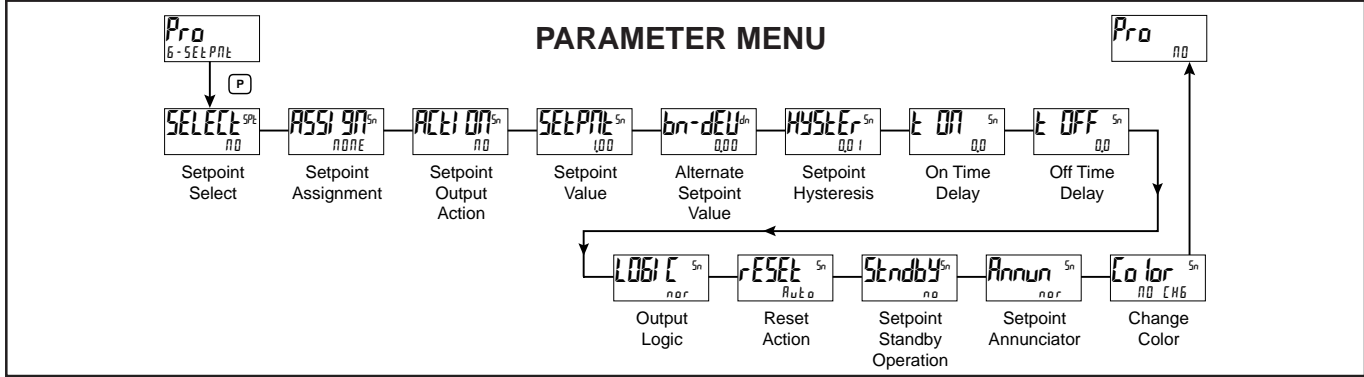

SETPOINT SELECT

n0 51 52 53 54

Enter the setpoint (alarm output) to be programmed. The “n” in the following parameters will reflect the chosen setpoint number. After the chosen setpoint is completely programmed, the display will return to n0. Repeat step for each setpoint to be programmed. The n0 chosen at SELEcTSPt, will return to Pro n0. The number of setpoints available is setpoint output card dependent.

SETPOINT ASSIGNMENT



none rEL AbS tAtAL

Selects the meter value to be used to trigger the Setpoint Alarm. The rEL setting will cause the setpoint to trigger off of the relative (net) input value. The relative input value is the absolute input value that includes the Display Offset Value. The AbS setting will cause the setpoint to trigger off of the absolute (gross) input value. The absolute input value is based on Module 1 dSP and IAP entries.

SETPOINT ACTION



n0 Ab-HI Ab-LO AU-HI
AU-LO dE-HI dE-LO bAND
bANDi n tAtLo tAtHi

Enter the desired Display Contrast Level (0-15) by using the arrow keys. The display contrast / viewing angle will actively move up or down as the levels are changed. This parameter also appears in Quick Programming Mode when enabled.

- n0 = No Setpoint Action
- Ab-HI = Absolute high, with balanced hysteresis
- Ab-LO = Absolute low, with balanced hysteresis
- AU-HI = Absolute high, with unbalanced hysteresis
- AU-LO = Absolute low, with unbalanced hysteresis
- dE-HI = deviation high, with unbalanced hysteresis
- dE-LO = deviation low, with unbalanced hysteresis
- bAND = Outside band, with unbalanced hysteresis
- bANDi n = Inside band, with unbalanced hysteresis
- tAtLo = Lower 6 digits of 9 digit Totalizer, with unbalanced hysteresis
- tAtHi = Upper 6 digits of 9 digit Totalizer, with unbalanced hysteresis

SETPOINT VALUE



- 199999 to 999999

Enter desired setpoint alarm value. These setpoint values can also be entered in the Display Mode during Program Lockout when the setpoint is programmed as ENt in Parameter Module 3.

BAND/DEVIATION VALUE



- 199999 to 999999

This parameter is only available in band and deviation setpoint actions. Enter desired setpoint band or deviation value.

HYSTERESIS VALUE



1 to 65000

Enter desired hysteresis value. See Setpoint Alarm Figures for visual explanation of how setpoint alarm actions (balance and unbalance) are affected by the hysteresis. When the setpoint is a control output, usually balance hysteresis is used. For alarm applications, usually unbalanced hysteresis is used. For unbalanced hysteresis modes, the hysteresis functions on the low side for high acting setpoints and functions on the high side for low acting setpoints. Note: Hysteresis eliminates output chatter at the switch point, while time delay can be used to prevent false triggering during process transient events.

ON TIME DELAY



0.0 to 3275.0 seconds

Enter the time value in seconds that the alarm is delayed from turning on after the trigger point is reached. A value of 0.0 allows the meter to update the alarm status per the response time listed in the Specifications. When the output logic is rEV, this becomes off time delay. Any time accumulated at power-off resets during power-up.

OFF TIME DELAY



0.0 to 3275.0 seconds

Enter the time value in seconds that the alarm is delayed from turning off after the trigger point is reached. A value of 0.0 allows the meter to update the alarm status per the response time listed in the Specifications. When the output logic is rEV, this becomes off time delay. Any time accumulated at power-off resets during power-up.

OUTPUT LOGIC



nor rEV

Enter the output logic of the alarm output. The nor logic leaves the output operation as normal. The rEV logic reverses the output logic. In rEV, the alarm states in the Setpoint Alarm Figures are reversed.

RESET ACTION



Auto LAtch1 LAtch2

Enter the reset action of the alarm output.

Auto = Automatic action; This action allows the alarm output to automatically reset off at the trigger points per the Setpoint Action shown in Setpoint Alarm Figures. The "on" alarm may be manually reset (off) immediately by a front panel function key or user input. The alarm remains reset off until the trigger point is crossed again.

LAtch1 = Latch with immediate reset action; This action latches the alarm output on at the trigger point per the Setpoint Action shown in Setpoint Alarm Figures. Latch means that the alarm output can only be turned off by front panel function key or user input manual reset, serial reset command or meter power cycle. When the user input or function key is activated (momentary or maintained), the corresponding "on" alarm output is reset immediately and remains off until the trigger point is crossed again. (Previously latched alarms will be off if power up Display Value is lower than setpoint value.)

LAtch2 = Latch with delay reset action; This action latches the alarm output on at the trigger point per the Setpoint Action shown in Setpoint Alarm Figures. Latch means that the alarm output can only be turned off by front panel function key or user input manual reset, serial reset command or meter power cycle. When the user input or function key is activated (momentary or maintained), the meter delays the event until the corresponding "on" alarm output crosses the trigger off point. (Previously latched alarms are off if power up Display Value is lower than setpoint value. During a power cycle, the meter erases a previous Latch 2 reset if it is not activated at power up.)

STANDBY OPERATION



no YES

When **YES**, the alarm is disabled (after a power up) until the trigger point is crossed. Once the alarm is on, the alarm operates normally per the Setpoint Action and Reset Mode.

SETPOINT ANNUNCIATOR



nor rEu FLASH OFF

The **OFF** mode disables display setpoint annunciators. The **nor** mode displays the corresponding setpoint annunciators of "on" alarm outputs. The **rEu** mode displays the corresponding setpoint annunciators of "off" alarms outputs. The **FLASH** mode flashes the corresponding setpoint annunciators of "on" alarm outputs.

CHANGE COLOR



NO CHG GREEN ORANGE rEd
GrnOrG rEdOrG rEdGrn LINE 1

MODULE 7 - SERIAL COMMUNICATIONS PARAMETERS (7-SERIAL)

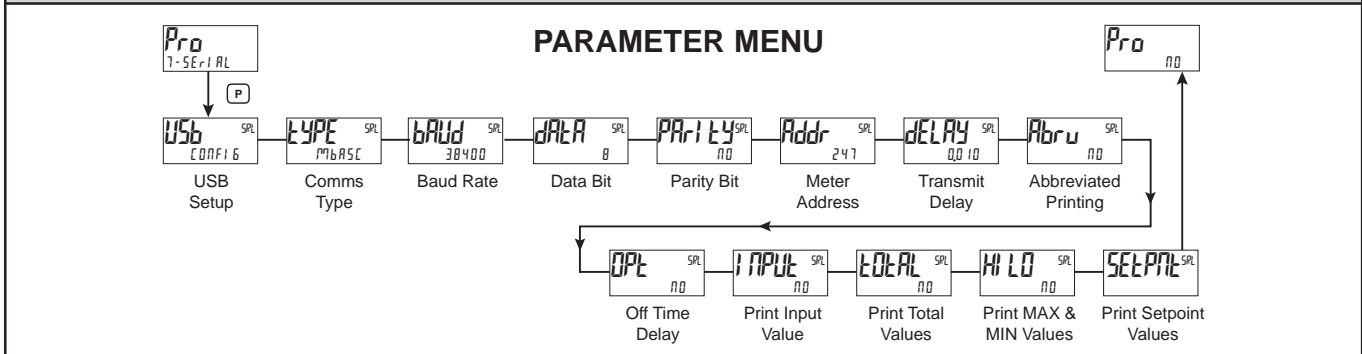

USB SETUP



CONF16 Part

CONF16 – Configurations USB with settings required to operate with Crimson configuration software. This will automatically internally configure the PAX2A to use ModBus RTU protocol, 38400 baud, 8 bits, and unit address of 247 when a USB cable is attached to PAX2A and PC. The serial port settings shown in 7- SERIAL (this module) will not change, or show this.

Part – Configures USB to utilize serial settings and protocol as configured in "7- SERIAL" (this module).

COMMUNICATIONS TYPE



ModBus - ModBus ASCII
rLC - RLC Protocol (ASCII)
ModBus - ModBus RTU

Select the desired communications protocol. Modbus is preferred as it provides access to all meter values and parameters. Since the Modbus protocol is included within the PAX2, the PAX Modbus option card, PAXCDC4, should not be used. The PAXCDC1 (RS485), or PAXCDC2 (RS232) card should be used instead.

BAUD RATE



1200 4800 19200
2400 9600 38400

Set the baud rate to match the other serial communications equipment on the serial link. Normally, the baud rate is set to the highest value that all the serial equipment are capable of transmitting and receiving.

DATA BIT



7 8

Select either 7 or 8 bit data word lengths. Set the word length to match the other serial communications equipment on the serial link.

PARITY BIT



NO EVEN Odd

Set the parity bit to match that of the other serial communications equipment on the serial link. The meter ignores the parity when receiving data and sets the parity bit for outgoing data. If no parity is selected with 7 bit word length, an additional stop bit is used to force the frame size to 10 bits.

METER UNIT ADDRESS

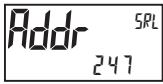

0 to 99 - RLC Protocol
1 to 247 - ModBus

Set the parity bit to match that of the other serial communications equipment on the serial link. The meter ignores the parity when receiving data and sets the parity bit for outgoing data. If no parity is selected with 7 bit word length, an additional stop bit is used to force the frame size to 10 bits.

TRANSMIT DELAY



0.010 to 0.250 seconds

Following a transmit value (“*” terminator) or Modbus command, the PAX2A will wait this minimum amount of time in seconds before issuing a serial response

ABBREVIATED PRINTING



NO YES

Select YES for full print or Command T transmissions (meter address, parameter data and mnemonics) or NO for abbreviated print transmissions (parameter data only). This will affect all the parameters selected in the print options. If the meter address is 00, it will not be sent during a full transmission.

PRINT OPTIONS



NO YES

YES - Enters the sub-menu to select the meter parameters to appear during a print request. For each parameter in the sub-menu, select for that parameter information to be sent during a print request or for that parameter information not to be sent. A print request is sometimes referred to as a block print because more than one parameter information (meter address, parameter data and mnemonics) can be sent to a printer or computer as a block.

DISPLAY	DESCRIPTION	FACTORY SETTING	MNEMONIC
INP	Signal Input	YES	INP
TOT	Total Value	NO	TOT
MAX	Max & Min	NO	MAX, MIN
SP1-4	Setpoint Values	NO	SP1-SP4

SERIAL COMMUNICATIONS

The PAX2A supports serial communications using the optional serial communication cards or via the USB programming port located on the side of the unit. When USB is being used (connected), the serial communication card is disabled. The PAX2A supports both the RLC protocol and also supports ModBus communications using the standard RS232 and RS485 Pax option cards. The Pax ModBus option card should not be used with the PAX2A, as the PAX2A internal ModBus protocol supports complete unit configuration, and is much more responsive.

USB

The USB programming port is primarily intended to be used to configure the PAX2A with the Crimson programming software. It can also however, be used as a virtual serial communications port following installation of the PAX2A USB drivers that are supplied with the Crimson software. When the USB port is being used, i.e. the USB cable is connected between PAX2A and PC, all serial communications with the serial option card (if used) is disabled.

USB Cable type required: USB A to Mini-B (not supplied)

PAX2A CONFIGURATION USING CRIMSON AND USB

1. Install Crimson software and drivers.
2. Supply power to PAX2A
3. Insure “USB” parameter in module 7-Serial, is set to “Default” (factory default setting).
4. Attach USB A – MiniB cable between PC and PAX2A
5. Create a new (File, New) or open an existing PAX2A database within Crimson.
6. Configure Crimson 2 Link, Options to ...

SERIAL MODBUS COMMUNICATIONS

Modbus Communications requires that the Serial Communication Type Parameter (TYPE) be set to “RTU” or “ASCII”.

PAX2A CONFIGURATION USING CRIMSON AND SERIAL COMMUNICATIONS CARD

1. Install Crimson software.
2. Install RS232 or RS485 card and connect communications cable from PAX2A to PC.
3. Supply power to PAX2A
4. Configure serial parameters in 7-Serial to RTU, 38,400 baud, address 247.
5. Create a new (File, New) or open an existing PAX2A database within Crimson.
6. Configure Crimson 2 Link, Options to serial port to which cable is attached (in step 2).

SUPPORTED FUNCTION CODES

FC03: Read Holding Registers

1. Up to 32 registers can be requested at one time.
2. HEX <8000> is returned for non-used registers.

FC04: Read Input Registers

1. Up to 32 registers can be requested at one time.
2. Block starting point can not exceed register boundaries.
3. HEX <8000> is returned in registers beyond the boundaries.
4. Input registers are a mirror of Holding registers.

FC06: Preset Single Register

1. HEX <8001> is echoed back when attempting to write to a read only register.
2. If the write value exceeds the register limit (see Register Table), then that register value changes to its high or low limit. It is also returned in the response.

FC16: Preset Multiple Registers

1. No response is given with an attempt to write to more than 32 registers at a time.
2. Block starting point cannot exceed the read and write boundaries (4001-XXXX).
3. If a multiple write includes read only registers, then only the write registers will change.

4. If the write value exceeds the register limit (see Register Table), then that register value changes to its high or low limit.

FC08: Diagnostics

The following is sent upon FC08 request:

Module Address, 08 (FC code), 04 (byte count), "Total Comms" 2 byte count, "Total Good Comms" 2 byte count, checksum of the string

"Total Comms" is the total number of messages received that were addressed to the PAX2. "Total Good Comms" is the total messages received by the PAX2A with good address, parity and checksum. Both counters are reset to 0 upon response to FC08 and at power-up.

FC17: Report Slave ID

The following is sent upon FC17 request:

RLC-PAX2A ab<0100h><20h><20h><10h>

a = SP Card, "0"-No SP, "2" or "4" SP

b = Linear Card "0" = None, "1" = Yes

<18h>Max Register Reads (24)

<18h>Max Register Writes (24)

<0100> Software Version Number (1.00)

<10h> Number Guid/Scratch Pad Regs (16)

SUPPORTED EXCEPTION CODES

01: Illegal Function

Issued whenever the requested function is not implemented in the meter.

02: Illegal Data Address

Issued whenever an attempt is made to access a single register that does not exist (outside the implemented space) or to access a block of registers that falls completely outside the implemented space.

03: Illegal Data Value

Issued when an attempt is made to read or write more registers than the meter can handle in one request.

07: Negative Acknowledge

Issued when a write to a register is attempted with an invalid string length.

PAX2A MODBUS REGISTER TABLE

The below limits are shown as Integers or HEX <> values. Read and write functions can be performed in either Integers or Hex as long as the conversion was done correctly. Negative numbers are represented by two's complement.

Note 1: The PAX2A should not be powered down while parameters are being changed. Doing so may corrupt the non-volatile memory resulting in checksum errors.

REGISTER ADDRESS	REGISTER NAME	LOW LIMIT	HIGH LIMIT	FACTORY SETTING	ACCESS	COMMENTS
FREQUENTLY USED REGISTERS						
40001	Input Relative Value (Hi word)	N/A	N/A	N/A	Read Only	Process value of present input level. This value is affected by Input Type, Resolution, Scaling, & Offset Value. (Relative Value = Absolute Input Value + Offset Value)
40002	Input Relative Value (Lo word)					
40003	Maximum Value (Hi word)	-199999	999999	N/A	Read/Write	
40004	Maximum Value (Lo word)					
40005	Minimum Value (Hi word)	-199999	999999	N/A	Read/Write	
40006	Minimum Value (Lo word)					
40007	Total Value (Hi word)	-199999999	999999999	N/A	Read/Write	
40008	Total Value (Lo word)					
40009	Setpoint 1 Value (Hi word)	-199999	999999	100	Read/Write	Active List (A or B)
40010	Setpoint 1 Value (Lo word)					
40011	Setpoint 2 Value (Hi word)	-199999	999999	200	Read/Write	Active List (A or B)
40012	Setpoint 2 Value (Lo word)					
40013	Setpoint 3 Value (Hi word)	-199999	999999	300	Read/Write	Active List (A or B)
40014	Setpoint 3 Value (Lo word)					
40015	Setpoint 4 Value (Hi word)	-199999	999999	400	Read/Write	Active List (A or B)
40016	Setpoint 4 Value (Lo word)					
40017	Setpoint 1 Band/Dev. Value (Hi word)	-199999	999999	0	Read/Write	Active List (A or B). Applicable only for Band or Deviation Setpoint Action.
40018	Setpoint 1 Band/Dev. Value (Lo word)					
40019	Setpoint 2 Band/Dev. Value (Hi word)	-199999	999999	0	Read/Write	Active List (A or B). Applicable only for Band or Deviation Setpoint Action.
40020	Setpoint 2 Band/Dev. Value (Lo word)					
40021	Setpoint 3 Band/Dev. Value (Hi word)	-199999	999999	0	Read/Write	Active List (A or B). Applicable only for Band or Deviation Setpoint Action.
40022	Setpoint 3 Band/Dev. Value (Lo word)					
40023	Setpoint 4 Band/Dev. Value (Hi word)	-199999	999999	0	Read/Write	Active List (A or B). Applicable only for Band or Deviation Setpoint Action.
40024	Setpoint 4 Band/Dev. Value (Lo word)					
40025	Setpoint Output Register (SOR)	0	15	N/A	Read/Write	Status of Setpoint Outputs. Bit State: 0 = Off, 1 = On. Bit 3 = S1, Bit 2 = S2, Bit 1 = S3, Bit 0 = S4. Outputs can only be activated/reset with this register when the respective bits in the Manual Mode Register (MMR) are set.
40026	Manual Mode Register (MMR)	0	31	0	Read/Write	Bit State: 0 = Auto Mode, 1 = Manual Mode Bit 4 = S1, Bit 3 = S2, Bit 2 = S3, Bit 1 = S4, Bit 0 = Linear Output
40027	Reset Output Register	0	15	0	Read/Write	Bit State: 1 = Reset Output, bit is returned to zero following reset processing; Bit 3 = S1, Bit 2 = S2, Bit 1 = S3, Bit 0 = S4
40028	Analog Output Register (AOR)	0	4095	0	Read/Write	Functional only if Linear Output is in Manual Mode. (MMR bit 0 = 1) Linear Output Card written to only if Linear Out (MMR bit 0) is set.
40029	Input Absolute Value (Hi word)	N/A	N/A	N/A	Read Only	Gross value of present Input level. This value is affected by Input Type, Resolution, Scaling, but not affected by Offset Value
40030	Input Absolute Value (Lo word)					
40031	Input Offset Value (Hi word)	-199999	999999	0	Read/Write	Relative Input Value (standard meter value) is sum of Input Offset Value and Input Absolute Value
40032	Input Offset Value (Lo word)					

REGISTER ADDRESS	REGISTER NAME	LOW LIMIT	HIGH LIMIT	FACTORY SETTING	ACCESS	COMMENTS	
	INPUT PARAMETERS					SEE MODULE 1 FOR PARAMETER DESCRIPTIONS	
40081	Input Range	0	26	10	Read/Write	0 = 250µA 5 = 250mV 11 = 100Ω 17 = TC-K 23 = RTD 385 1 = 2.5mA 6 = 2V 12 = 1KΩ 18 = TC-R 24 = RTD 392 2 = 25mA 7 = 10V 13 = 10KΩ 19 = TC-S 25 = RTD 672 3 = 250mA 8 = 25V 14 = TC-T 20 = TC-B 26 = RTD 427 4 = 2A 9 = 100V 15 = TC-E 21 = TC-N 10 = 200V 16 = TC-J 22 = TC-C	
40082	Temperature Scale (TC or RTD only)	0	1	1	Read/Write	0 = °C, 1 = °F	
40083	Ice Point Compensation (TC only)	0	1	1	Read/Write	0 = Off, 1 = On	
40084	ADC Conversion Rate (samples/sec)	0	5	0	Read/Write	0 = 5, 1 = 10, 2 = 20, 3 = 40, 4 = 80, 5 = 160	
40085	Decimal Point	0	4	2	Read/Write	0 = 0, 1 = 0.0, 2 = 0.00, 3 = 0.000, 4 = 0.0000	
40086	Rounding Factor	0	6	0	Read/Write	0 = 1, 1 = 2, 2 = 5, 3 = 10, 4 = 20, 5 = 50, 6 = 100	
40087	Digital Input Filter	0	250	10	Read/Write	1 = 0.1 Second	
40088	Filter Band	0	250	10	Read/Write	1 = 1 display unit	
40089	Input Scaling Points in List Function	0	1	0	Read/Write	0 = No, 1 = Yes	
List A	List B	Input Scaling Points Parameters					
40101	40201	Number of Scaling Points	2	16	2	Read/Write	Number of Linearization Scaling Points
40102	40202	Reserved	N/A	N/A	N/A	N/A	
40103	40203	Scaling Pt.1 Input Value (Hi word)	-199999	999999	0	Read/Write	1 = 0.001
40104	40204	Scaling Pt.1 Input Value (Lo word)					
40105	40205	Scaling Pt.1 Display Value (Hi word)	-199999	999999	0	Read/Write	
40106	40206	Scaling Pt.1 Display Value (Lo word)					
thru	thru	Scaling Pts. 2 thru 15 Values	Registers 40107-40162 and 40207-40262 hold values for Scaling Points 2 thru 15, and follow the same ordering as Scaling Point 1.
40163	40263	Scaling Pt.16 Input Value (Hi word)	-199999	999999	0	Read/Write	
40164	40264	Scaling Pt.16 Input Value (Lo word)					
40165	40265	Scaling Pt.16 Display Value (Hi word)	-199999	999999	0	Read/Write	
40166	40266	Scaling Pt.16 Display Value (Lo word)					
List A	List B	Setpoint Values					
40167	40267	Setpoint 1 Value (Hi word)	-199999	999999	100	Read/Write	
40168	40268	Setpoint 1 Value (Lo word)					
40169	40269	Setpoint 2 Value (Hi word)	-199999	999999	200	Read/Write	
40170	40270	Setpoint 2 Value (Lo word)					
40171	40271	Setpoint 3 Value (Hi word)	-199999	999999	300	Read/Write	
40172	40272	Setpoint 3 Value (Lo word)					
40173	40273	Setpoint 4 Value (Hi word)	-199999	999999	400	Read/Write	
40174	40274	Setpoint 4 Value (Lo word)					
40175	40275	Setpoint 1 Band/Dev. Value (Hi word)	-199999	999999	0	Read/Write	Applicable only for Band or Deviation Setpoint Action.
40176	40276	Setpoint 1 Band/Dev. Value (Lo word)					
40177	40277	Setpoint 2 Band/Dev. Value (Hi word)	-199999	999999	0	Read/Write	Applicable only for Band or Deviation Setpoint Action.
40178	40278	Setpoint 2 Band/Dev. Value (Lo word)					
40179	40279	Setpoint 3 Band/Dev. Value (Hi word)	-199999	999999	0	Read/Write	Applicable only for Band or Deviation Setpoint Action.
40180	40280	Setpoint 3 Band/Dev. Value (Lo word)					
40181	40281	Setpoint 4 Band/Dev. Value (Hi word)	-199999	999999	0	Read/Write	Applicable only for Band or Deviation Setpoint Action.
40182	40282	Setpoint 4 Band/Dev. Value (Lo word)					
	USER INPUT / FUNCTION KEYS					SEE MODULE 2 FOR PARAMETER DESCRIPTIONS	
40301	User Input Active State	0	1	0	Read/Write	0 = Active Low, 1 = Active High	
40302	User Input 1 Action	0	28	0	Read/Write	0 = NO 8 = d-tot 16 = r-HL 24 = r-4 1 = PLOC 9 = r-tot1 17 = dISP 25 = r-34 2 = rEL 10 = r-tot2 18 = d-LEV 26 = r-234 3 = d-rEL 11 = E-tot 19 = Color 27 = r-ALL 4 = d-HLd 12 = d-HI 20 = LISt 28 = Print 5 = A-HLd 13 = r-HI 21 = r-1 6 = SYNC 14 = d-Lo 22 = r-2 7 = bAt 15 = r-Lo 23 = r-3	
40303	User Input 2 Action	0	28	0	Read/Write	Same as User Input 1 Action	
40304	User F1 Key Action	0	17	0	Read/Write	0 = NO 5 = r-HI 10 = r-1 15 = r-234 1 = rEL 6 = r-Lo 11 = r-2 16 = r-ALL 2 = d-rEL 7 = r-HL 12 = r-3 17 = Print 3 = bAt 8 = d-LEV 13 = r-4 4 = r-tot 9 = LISt 14 = r-34	
40305	User F2 Key Action	0	17	0	Read/Write	Same as User F1 Key Action	
40306	User F1 Second Action	0	17	0	Read/Write	Same as User F1 Key Action	
40307	User F2 Second Action	0	17	0	Read/Write	Same as User F1 Key Action	
	DISPLAY PARAMETERS					SEE MODULE 3 FOR PARAMETER DESCRIPTIONS	
40331	Line 1 Display Color	0	2	0	Read/Write	0 = Green, 1 = Red, 2 = Orange	
40332	Display Intensity Level	0	4	4	Read/Write	0 = Min.(off), 4 = Max.	
40333	Display Contrast Level	0	15	7	Read/Write		

REGISTER ADDRESS	REGISTER NAME	LOW LIMIT	HIGH LIMIT	FACTORY SETTING	ACCESS	COMMENTS
40334	Line 1 Display	0	8	1	Read/Write	0 = None, 1 = Input, 2 = Total, 3 = Hi, 4 = Lo, 5 = S1, 6 = S2, 7 = S3, 8 = S4
40335	Units Mnemonic	0	1	0	Read/Write	0 = Off, 1 = List
40336	Units Digit 1 (Left)	0	46	0	Read/Write	0 = . 7 = f 14 = g 21 = h 28 = i 35 = j 42 = k 1 = A 8 = H 15 = P 22 = Y 29 = 5 36 = 9 43 = u 2 = b 9 = l 16 = g 23 = l 30 = 6 37 = h 44 = . 3 = c 10 = j 17 = p 24 = 0 31 = 7 38 = , 45 = ° 4 = d 11 = P 18 = 5 25 = l 32 = 8 39 = n 46 = 5 = E 12 = L 19 = t 26 = l 33 = 9 40 = o 6 = F 13 = fl 20 = U 27 = 3 34 = c 41 = 9
40337	Units Digit 2 (Center)	0	46	0	Read/Write	Same selections as Digit 1
40338	Units Digit 3 (Right)	0	46	0	Read/Write	Same selections as Digit 1
40339	Line 2 Input Display Access	0	2	0	Read/Write	0=LOC, 1=d-rEd, 2=d-Ent
40340	Line 2 Totalizer Display Access	0	2	0	Read/Write	0=LOC, 1=d-rEd, 2=d-Ent
40341	Line 2 Maximum (Hi) Value Access	0	2	0	Read/Write	0=LOC, 1=d-rEd, 2=d-Ent
40342	Line 2 Minimum (Lo) Value Access	0	2	0	Read/Write	0=LOC, 1=d-rEd, 2=d-Ent
40343	Line 2 List Selection Access	0	5	0	Read/Write	0=LOC, 1=d-rEd, 2=d-Ent, 3=P-rEd, 4=P-Ent, 5=HidE
40344	Line 2 Setpoint 1 Value Access	0	5	0	Read/Write	0=LOC, 1=d-rEd, 2=d-Ent, 3=P-rEd, 4=P-Ent, 5=HidE
40345	Line 2 S1 Band/Dev. Value Access	0	5	0	Read/Write	0=LOC, 1=d-rEd, 2=d-Ent, 3=P-rEd, 4=P-Ent, 5=HidE
40346	Line 2 Setpoint 2 Value Access	0	5	0	Read/Write	0=LOC, 1=d-rEd, 2=d-Ent, 3=P-rEd, 4=P-Ent, 5=HidE
40347	Line 2 S2 Band/Dev.Value Access	0	5	0	Read/Write	0=LOC, 1=d-rEd, 2=d-Ent, 3=P-rEd, 4=P-Ent, 5=HidE
40348	Line 2 Setpoint 3 Value Access	0	5	0	Read/Write	0=LOC, 1=d-rEd, 2=d-Ent, 3=P-rEd, 4=P-Ent, 5=HidE
40349	Line 2 S3 Band/Dev.Value Access	0	5	0	Read/Write	0=LOC, 1=d-rEd, 2=d-Ent, 3=P-rEd, 4=P-Ent, 5=HidE
40350	Line 2 Setpoint 4 Value Access	0	5	0	Read/Write	0=LOC, 1=d-rEd, 2=d-Ent, 3=P-rEd, 4=P-Ent, 5=HidE
40351	Line 2 S4 Band/Dev.Value Access	0	5	0	Read/Write	0=LOC, 1=d-rEd, 2=d-Ent, 3=P-rEd, 4=P-Ent, 5=HidE
40352	Reserved	N/A	N/A	N/A	N/A	
40353	Reserved	N/A	N/A	N/A	N/A	
40354	Reserved	N/A	N/A	N/A	N/A	
40355	Reserved	N/A	N/A	N/A	N/A	
40356	Line 2 Display Color Access	0	3	0	Read/Write	0=LOC, 1=P-rEd, 2=P-Ent, 3=HidE
40357	Line 2 Display Intensity Level Access	0	3	0	Read/Write	0=LOC, 1=P-rEd, 2=P-Ent, 3=HidE
40358	Line 2 Display Contrast Level Access	0	3	0	Read/Write	0=LOC, 1=P-rEd, 2=P-Ent, 3=HidE
40359	Line 2 Zero (Tare) Display Access	0	2	0	Read/Write	0=LOC, 1=P-Ent, 2=HidE
40360	Line 2 Batch Input to Totalizer Access	0	2	0	Read/Write	0=LOC, 1=P-Ent, 2=HidE
40361	Line 2 Reset Totalizer Access	0	2	0	Read/Write	0=LOC, 1=P-Ent, 2=HidE
40362	Line 2 Reset Max (Hi) Display Access	0	2	0	Read/Write	0=LOC, 1=P-Ent, 2=HidE
40363	Line 2 Reset Min (Lo) Display Access	0	2	0	Read/Write	0=LOC, 1=P-Ent, 2=HidE
40364	Line 2 Reset Max and Min Access	0	2	0	Read/Write	0=LOC, 1=P-Ent, 2=HidE
40365	Line 2 Reset Alarm 1 Access	0	2	0	Read/Write	0=LOC, 1=P-Ent, 2=HidE
40366	Line 2 Reset Alarm 2 Access	0	2	0	Read/Write	0=LOC, 1=P-Ent, 2=HidE
40367	Line 2 Reset Alarm 3 Access	0	2	0	Read/Write	0=LOC, 1=P-Ent, 2=HidE
40368	Line 2 Reset Alarm 4 Access	0	2	0	Read/Write	0=LOC, 1=P-Ent, 2=HidE
40369	Line 2 Reset Alarm 3 and 4 Access	0	2	0	Read/Write	0=LOC, 1=P-Ent, 2=HidE
40370	Line 2 Reset Alarm 2, 3 and 4 Access	0	2	0	Read/Write	0=LOC, 1=P-Ent, 2=HidE
40371	Line 2 Reset All Alarms (1-4) Access	0	2	0	Read/Write	0=LOC, 1=P-Ent, 2=HidE
40372	Line 2 Print Request Access	0	2	0	Read/Write	0=LOC, 1=P-Ent, 2=HidE
40373	Line 2 Security Code Value	0	250	0	Read/Write	
	SECONDARY PARAMETERS					SEE MODULE 4 FOR PARAMETER DESCRIPTIONS
40381	Max (Hi) Capture Value Assignment	0	1	0	Read/Write	0 = Relative, 1 = Absolute
40382	Max (Hi) Capture Delay Time	0	32750	10	Read/Write	0 = Max Update Rate, 1 = 0.1Sec
40383	Min (Lo) Capture Value Assignment	0	1	0	Read/Write	0 = Relative, 1 = Absolute
40384	Min (Lo) Capture Delay Time	0	32750	10	Read/Write	0 = Max Update Rate, 1 = 0.1Sec
40385	Display Update (readings per second)	0	4	0	Read/Write	0 = 1, 1 = 2, 2 = 5, 3 = 10, 4 = 20
	TOTALIZER PARAMETERS					SEE MODULE 5 FOR PARAMETER DESCRIPTIONS
40391	Totalizer Decimal Point	0	4	3	Read/Write	0 = 0, 1 = 0.0, 2 = 0.00, 3 = 0.000, 4 = 0.0000
40392	Totalizer Time Base	0	3	1	Read/Write	0 = Second, 1 = Minute, 2 = Hour, 3 = Day
40393	Totalizer Scale Factor	1	65000	1000	Read/Write	1 = 0.001
40394	Totalizer Reset at Power Up	0	1	0	Read/Write	0 = No, 1 = Yes
40395	Totalizer Low Cut Value (Hi word)					
40396	Totalizer Low Cut Value (Lo word)	-199999	999999	-199999	Read/Write	
	SETPOINT PARAMETERS					SEE MODULE 6 FOR PARAMETER DESCRIPTIONS
	Setpoint 1					
40401	Assignment	0	3	0	Read/Write	0 = None, 1 = Rel, 2 = Abs, 3 = Total
40402	Action	0	10	0	Read/Write	0=No, 1=Ab-HI, 2=Ab-LO, 3=AU-HI, 4=AU-LO, 5=dE-HI, 6=dE-LO, 7=bANd, 8=bNdlN, 9=totLo, 10=totHI
40403	Hysteresis Value	1	65000	2	Read/Write	1 = 1 Display Unit
40404	On Time Delay	0	32750	0	Read/Write	1 = 0.1 Second

REGISTER ADDRESS	REGISTER NAME	LOW LIMIT	HIGH LIMIT	FACTORY SETTING	ACCESS	COMMENTS
40405	Off Time Delay	0	32750	0	Read/Write	1 = 0.1 Second
40406	Output Logic	0	1	0	Read/Write	0 = Normal, 1 = Reverse
40407	Reset Action	0	2	0	Read/Write	0 = Auto, 1 = Latch1, 2 = Latch2
40408	Standby Operation	0	1	0	Read/Write	0 = No, 1 = Yes
40409	Annunciator	0	3	1	Read/Write	0 = Off, 1 = Normal, 2 = Reverse, 3 = Flash
40410	Color	0	7	0	Read/Write	0 = No Change, 1 = Green, 2 = Orange, 3 = Red, 4 = Grn/Org, 5 = Red/Org, 6 = Red/Grn, 7 = Line 1 Color
40411	Probe Failure Action (TC or RTD only)	0	1	0	Read/Write	0 = Off, 1 = On (only applies for TC or RTD input)
	Setpoint 2					
40421	Assignment	0	3	0	Read/Write	0 = None, 1 = Rel, 2 = Abs, 3 = Total
40422	Action	0	10	0	Read/Write	0=No, 1=Ab-HI, 2=Ab-LO, 3=AU-HI, 4=AU-LO, 5=dE-HI, 6=dE-LO, 7=bANd, 8=bNdIn, 9=totLo, 10=totHI
40423	Hysteresis Value	1	65000	2	Read/Write	1 = 1 Display Unit
40424	On Time Delay	0	32750	0	Read/Write	1 = 0.1 Second
40425	Off Time Delay	0	32750	0	Read/Write	1 = 0.1 Second
40426	Output Logic	0	1	0	Read/Write	0 = Normal, 1 = Reverse
40427	Reset Action	0	2	0	Read/Write	0 = Auto, 1 = Latch1, 2 = Latch2
40428	Standby Operation	0	1	0	Read/Write	0 = No, 1 = Yes
40429	Annunciator	0	3	1	Read/Write	0 = Off, 1 = Normal, 2 = Reverse, 3 = Flash
40430	Color	0	7	0	Read/Write	0 = No Change, 1 = Green, 2 = Orange, 3 = Red, 4 = Grn/Org, 5 = Red/Org, 6 = Red/Grn, 7 = Line 1 Color
40431	Probe Failure Action (TC or RTD only)	0	1	0	Read/Write	0 = Off, 1 = On (only applies for TC or RTD input)
	Setpoint 3					
40441	Assignment	0	3	0	Read/Write	0 = None, 1 = Rel, 2 = Abs, 3 = Total
40442	Action	0	10	0	Read/Write	0=No, 1=Ab-HI, 2=Ab-LO, 3=AU-HI, 4=AU-LO, 5=dE-HI, 6=dE-LO, 7=bANd, 8=bNdIn, 9=totLo, 10=totHI
40443	Hysteresis Value	1	65000	2	Read/Write	1 = 1 Display Unit
40444	On Time Delay	0	32750	0	Read/Write	1 = 0.1 Second
40445	Off Time Delay	0	32750	0	Read/Write	1 = 0.1 Second
40446	Output Logic	0	1	0	Read/Write	0 = Normal, 1 = Reverse
40447	Reset Action	0	2	0	Read/Write	0 = Auto, 1 = Latch1, 2 = Latch2
40448	Standby Operation	0	1	0	Read/Write	0 = No, 1 = Yes
40449	Annunciator	0	3	1	Read/Write	0 = Off, 1 = Normal, 2 = Reverse, 3 = Flash
40450	Color	0	7	0	Read/Write	0 = No Change, 1 = Green, 2 = Orange, 3 = Red, 4 = Grn/Org, 5 = Red/Org, 6 = Red/Grn, 7 = Line 1 Color
40451	Probe Failure Action (TC or RTD only)	0	1	0	Read/Write	0 = Off, 1 = On (only applies for TC or RTD input)
	Setpoint 4					
40461	Assignment	0	3	0	Read/Write	0 = None, 1 = Rel, 2 = Abs, 3 = Total
40462	Action	0	10	0	Read/Write	0=No, 1=Ab-HI, 2=Ab-LO, 3=AU-HI, 4=AU-LO, 5=dE-HI, 6=dE-LO, 7=bANd, 8=bNdIn, 9=totLo, 10=totHI
40463	Hysteresis Value	1	65000	2	Read/Write	1 = 1 Display Unit
40464	On Time Delay	0	32750	0	Read/Write	1 = 0.1 Second
40465	Off Time Delay	0	32750	0	Read/Write	1 = 0.1 Second
40466	Output Logic	0	1	0	Read/Write	0 = Normal, 1 = Reverse
40467	Reset Action	0	2	0	Read/Write	0 = Auto, 1 = Latch1, 2 = Latch2
40468	Standby Operation	0	1	0	Read/Write	0 = No, 1 = Yes
40469	Annunciator	0	3	1	Read/Write	0 = Off, 1 = Normal, 2 = Reverse, 3 = Flash
40470	Color	0	7	0	Read/Write	0 = No Change, 1 = Green, 2 = Orange, 3 = Red, 4 = Grn/Org, 5 = Red/Org, 6 = Red/Grn, 7 = Line 1 Color
40471	Probe Failure Action (TC or RTD only)	0	1	0	Read/Write	0 = Off, 1 = On (only applies for TC or RTD input)
	SERIAL COMMUNICATIONS PARAMETERS					SEE MODULE 7 FOR PARAMETER DESCRIPTIONS
40481	USB Mode	0	1	0	Read/Write	0 = Configuration, 1 = Port
40482	Type	0	2	2	Read/Write	0 = RLC Protocol (ASCII), 1 = Modbus RTU, 2 = Modbus ASCII
40483	Baud Rate	0	7	7	Read/Write	0=1200, 1=2400, 2=4800, 3=9600, 4=19200, 5=38400
40484	Data Bits	0	1	1	Read/Write	0 = 7 Bits, 1 = 8 Bits
40485	Parity	0	2	0	Read/Write	0 = None, 1 = Even, 2 = Odd
40486	Address	0	99	247	Read/Write	RLC Protocol: 0-99
		1	247			Modbus: 1-247
40487	Transmit Delay	0	250	10	Read/Write	1 = 0.001 Second
40488	Abbreviated Transmission (RLC only)	0	1	0	Read/Write	0 = No, 1 = Yes (Not used when communications type is Modbus)

REGISTER ADDRESS	REGISTER NAME	LOW LIMIT	HIGH LIMIT	FACTORY SETTING	ACCESS	COMMENTS
40489	Print Options (RLC only)	0	15	0	Read/Write	0 = No, 1 = Yes (Not used when communications type is Modbus) Bit 0 – Print Input Value, Bit 1 – Print Total Value, Bit 2 – Print Max & Min Values, Bit 3 – Print Setpoint Values
40490	Load Serial Settings	0	1	0	Read/Write	Changing 40481-40487 will not update the PAX2A until this register is written with a 1. After the write, the communicating device must be changed to new PAX2A settings and this register returns to 0.
ANALOG OUTPUT PARAMETERS						SEE MODULE 8 FOR PARAMETER DESCRIPTIONS
40491	Type	0	2	1	Read/Write	0 = 0-20 mA, 1 = 4-20 mA, 2 = 0-10 V
40492	Assignment	0	9	0	Read/Write	0=NONE, 1=rEL, 2=AbS, 3=tOtAL, 4=HI, 5=LO, 6=S1, 7=S2, 8=S3, 9=S4
40493	Analog Low Scale Value (Hi word)	-199999	999999	0	Read/Write	Display value that corresponds with 0 V, 0 mA or 4 mA output
40494	Analog Low Scale Value (Lo word)					
40495	Analog High Scale Value (Hi word)	-199999	999999	10000	Read/Write	Display value that corresponds with 10 V or 20 mA output
40496	Analog High Scale Value (Lo word)					
40497	Update time	0	100	0	Read/Write	0 = Max update rate, 1 = 0.1 Second
40498	Probe Failure Action (TC or RTD only)	0	1	0	Read/Write	0 = Low Scale, 1 = High Scale (only applies for TC or RTD input)
FACTORY SERVICE						
40501-40506	Factory Service Registers	N/A	N/A	N/A	Read/Write	Factory Use Only - Do Not Modify
41001-41010	Slave ID	N/A	N/A	N/A	Read Only	RLC-PAX2A <a><0100h><0020h><0010h> > <a> = SP Card Status. "0"-No Card, "2"-Dual SP, "4"-Quad SP = Linear Card Status. "0"-Not Installed, "1"-Installed <0100h> = Version Number (1.00 or higher) <0020h><0020h> = 32 Register Writes, 32 Register Reads (Max.) <0010h> = 16 Register GUID/Scratch
41101-41116	GUID/Scratch	N/A	N/A	N/A	Read/Write	Reserved (may be used in future RLC software)

SERIAL RLC PROTOCOL COMMUNICATIONS

RLC Communications requires the Serial Communications Type Parameter (TYPE) be set to "rLC".

SENDING SERIAL COMMANDS AND DATA

When sending commands to the meter, a string containing at least one command character must be constructed. A command string consists of a command character, a value identifier, numerical data (if writing data to the meter) followed by a the command terminator character * or \$.

Command Chart

COMMAND	DESCRIPTION	NOTES
N	Address Specifier	or two digit node address. Not required when address = 0.
T	Transmit Value (read)	Read a register from the meter. Must be followed by register ID character
V	Value Change (write)	Write to register or output. Must be followed by register ID character.
R	Reset	Reset a register or output. Registers are defined in programming.
P	Block Print Request	Initiates a block print output. Registers are defined in programming.

Command String Construction

The command string must be constructed in a specific sequence. The meter does not respond with an error message to invalid commands. The following procedure details construction of a command string:

- The first characters consist of the Node Address Specifier (N) followed by a 1 or 2 character address number. The address number of the meter is programmable. If the node address is 0, this command and the node address itself may be omitted. This is the only command that may be used in conjunction with other commands.
- After the address specifier, the next character is the command character.
- The next character is the Register ID. This identifies the register that the command affects. The P command does not require a Register ID character. It prints according to the selections made in print options.

- If constructing a value change command (writing data), the numeric data is sent next.
- All command strings must be terminated with the string termination characters * or \$. The meter does not begin processing the command string until this character is received. See Timing Diagram figure for differences between terminating characters.

Register Identification Chart

ID	VALUE DESCRIPTION	REGISTER ID	APPLICABLE COMMANDS/COMMENTS
A	Input	INP	T, P
B	Total	TOT	T, P, R (Reset command resets total to zero)
C	Max Input	MAX	T, P, R (Reset command resets Max to current reading)
D	Min Input	MIN	T, P, R (Reset command resets Min to current reading)
E	Setpoint 1	SP1	T, P, V, R (Reset command resets the setpoint output)
F	Setpoint 2	SP2	
G	Setpoint 3	SP3	
H	Setpoint 4	SP4	
I	Analog Output Register	AOR	T, V
J	Control Status Register	CSR	T, V

Command String Examples:

- Node address = 17, Write 350 to Setpoint 1, response delay of 2 msec min
String: N17VE350\$
- Node address = 5, Read Input value, response delay of 50 msec min
String: N5TA*
- Node address = 0, Reset Setpoint 4 output, response delay of 50 msec min
String: RH*

Sending Numeric Data

Numeric data sent to the meter must be limited to 5 digits (-19,999 to 99,999). If more than 5 digits are sent, the meter accepts the last 5. Leading zeros are ignored. Negative numbers must have a minus sign. The meter ignores any decimal point and conforms the number to the scaled resolution. (For example: the meter's scaled decimal point position = 0.0 and 25 is written to a register. The value of the register is now 2.5 In this case, write a value = 25.0).

Note: Since the meter does not issue a reply to value change commands, follow with a transmit value command for readback verification.

Receiving Data

Data is transmitted by the meter in response to either a transmit command (T), a print block command (P) or User Function print request. The response from the meter is either a full field transmission or an abbreviated transmission. In this case, the response contains only the numeric field. The meter response mode is established in programming.

Full Field Transmission

Byte Description

1, 2 2 byte Node Address field [00-99]
 3 <SP> (Space)
 4-6 3 byte Register Mnemonic field
 7-18
 19 <CR> carriage return
 20 <LF> line feed
 21 <SP>* (Space)
 22 <CR>* carriage return
 23 <LF>* line feed

* These characters only appear in the last line of a block print.

The first two characters transmitted are the node address, unless the node address assigned =0, in which case spaces are substituted. A space follows the node address field. The next three characters are the register ID (Serial Mnemonic).

The numeric data is transmitted next. The numeric field is 12 characters long (to accommodate the 10 digit totalizer), with the decimal point position floating within the data field. Negative value have a leading minus sign. The data field is right justified with leading spaces.

The end of the response string is terminated with a carriage return <CR> and <LF>. When block print is finished, an extra <SP><CR> <LF> is used to provide separation between the blocks.

Abbreviated Transmission

Byte Description

1-12 12 byte data field, 10 bytes for number, one byte for sign, one byte for decimal point
 13 <CR> carriage return
 14 <LF> line feed
 15 <SP>* (Space)
 16 <CR>* carriage return

Meter Response Examples:

- Node address = 17, full field response, Input = 875
 17 INP 875 <CR><LF>
- Node address = 0, full field response, Setpoint 2 = -250.5
 SP2 -250.5<CR><LF>
- Node address = 0, abbreviated response, Setpoint 2 = 250, last line of block print
 250<CR><LF><SP><CR><LF>

SERIAL COMMANDS FOR PAX SOFTWARE

(CSR) Control Status Register

The Control Status Register is used to both directly control the meter's outputs (setpoints and analog output), and interrogate the state of the setpoint outputs. The register is bit mapped with each bit position within the register assigned to a particular control function. The control function are invoked by writing to each bit position. The bit position definitions are:

- bit 0: Setpoint 1 Output Status
 0 = output off
 1 = output on
- bit 1: Setpoint 2 Output Status
 0 = output off
 1 = output on
- bit 2: Setpoint 3 Output Status
 0 = output off
 1 = output on

- bit 3: Setpoint 4 Output Status
 0 = output off
 1 = output on
- bit 4: Manual Mode
 0 = automatic mode
 1 = manual mode
- bit 5: Always stays 0, even if 1 is sent.
- bit 6: Sensor Status (TC or RTD only)
 0 = sensor normal
 1 = sensor fail
- bit 7: Always stays 0, even if 1 is sent.

Although the register is bit mapped starting with bit 7, HEX <> characters are sent in the command string. Bits 7 and 5 always stay a zero, even if a "1" is sent. This allows ASCII characters to be used with terminals that may not have extended character capabilities.

Writing a "1" to bit 4 of CSR selects manual mode. In this mode, the setpoint outputs are defined by the values written to the bits b0, b1, b2, b3; and the analog output is defined by the value written to the AOR. Internal control of these outputs is then overridden.

In automatic mode, the setpoint outputs can only be reset off. Writing to the setpoint output bits of the CSR has the same effect as a Reset command (R). The contents of the CSR may be read to interrogate the state of the setpoint outputs and to check the status of the temperature sensor (TC or RTD only).

Examples:

- Set manual mode, turn all setpoints off:
 7 6 5 4 3 2 1 0 : bit location
 VJ<30>* or VJ0* ASCII 0 = 0 0 1 1 0 0 0 0 or <30>
 V is command write, J is CSR and * is terminator.
- Turn SP1, SP3 outputs on and SP2, SP4 outputs off:
 7 6 5 4 3 2 1 0 : bit location
 VJ<35>* or VJ5* ASCII 5 = 0 0 1 1 0 1 0 1 or <35>
- Select Automatic mode:
 7 6 5 4 3 2 1 0 : bit location
 VJ<40>* or VJ@* ASCII @ = 0 1 0 0 0 0 0 0 or <40>

Note: Avoid writing values <0A> (LF), <0D> (CR), <24> (\$) and <2E> () to the CSR. These values are interpreted by the meter as end of command control codes and will prematurely end the write operation.*

(AOR) Analog Output Register

The Analog Output Register controls the analog output of the meter. The manual mode must first be engaged by setting bit 4 of the Control Status Register. The range of values of this register is 0 to 4095, which corresponds to 0 mA, 0 V and 20 mA, 10 V; respectively. The table lists correspondence of the output signal with the register value.

Register Value	Output Signal*	
	I (mA)	V (V)
0	0.00	0.000
1	0.005	0.0025
2047	10.000	5.000
4094	19.995	9.9975
4095	20.000	10.000

**Due to the absolute accuracy rating and resolution of the output card, the actual output signal may differ 0.15% FS from the table values. The output signal corresponds to the range selected (20 mA or 10 V).*

Writing to this register while the meter is in the manual mode causes the output signal to update immediately. While in the automatic mode, this register may be written to, but the output will not update until the meter is placed in manual mode.

Examples:

- Set output to full scale:
 V14095*
- Set output to zero scale:
 V10*

COMMAND RESPONSE TIME

The meter can only receive data or transmit data at any one time (half-duplex operation). The meter ignores commands while transmitting data, but instead uses RXD as a busy signal. When sending commands and data to the meter, a delay must be imposed before sending another command. This allows enough time for the meter to process the command and prepare for the next command.

Timing Diagrams

NO REPLY FROM METER

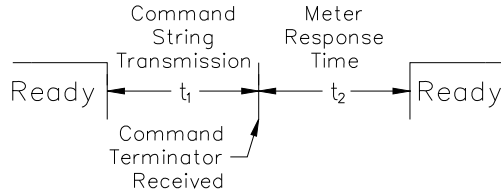

RESPONSE FROM METER

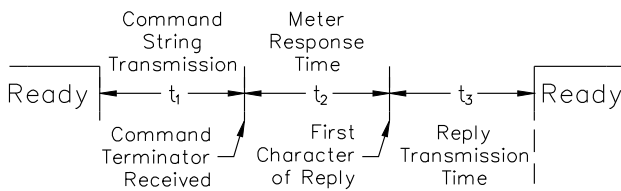

At the start of the time interval t_1 , the computer program prints or writes the string to the com port, thus initiating a transmission. During t_1 , the command characters are under transmission and at the end of this period, the command terminating character (*) is received by the meter. The time duration of t_1 is dependent on the number of characters and baud rate of the channel.

$$t_1 = (10 \text{ times the \# of characters}) / \text{baud rate}$$

At the start of time interval t_2 , the meter starts the interpretation of the command and when complete, performs the command function. This time interval t_2 varies from 2 msec to 50 msec. If no response from the meter is expected, the meter is ready to accept another command.

If the meter is to reply with data, the time interval t_2 is controlled by the use of the command terminating character. The standard command line terminating character is '*'. This terminating character results in a response time window of 50 msec minimum and 100 msec maximum. This allows sufficient time for the release of the sending driver on the RS485 bus. Terminating the command line with '\$' results in a response time window (t_2) of 2 msec minimum and 50 msec maximum. The faster response time of this terminating character requires that sending drivers release within 2 msec after the terminating character is received.

At the beginning of time interval t_3 , the meter responds with the first character of the reply. As with t_1 , the time duration of t_3 is dependent on the number of characters and baud rate of the channel. At the end of t_3 , the meter is ready to receive the next command.

$$t_3 = (10 \text{ times the \# of characters}) / \text{baud rate}$$

The maximum serial throughput of the meter is limited to the sum of the times t_1 , t_2 and t_3 .

COMMUNICATION FORMAT

Data is transferred from the meter through a serial communication channel. In serial communications, the voltage is switched between a high and low level at a predetermined rate (baud rate) using ASCII encoding. The receiving device reads the voltage levels at the same intervals and then translates the switched levels back to a character.

The voltage level conventions depend on the interface standard. The table lists the voltage levels for each standard.

LOGIC	INTERFACE STATE	RS232*	RS485*
1	mark (idle)	TXD,RXD; -3 to -15 V	a-b < -200 mV
0	space (active)	TXD,RXD; +3 to +15 V	a-b > +200 mV

* Voltage levels at the Receiver

Data is transmitted one byte at a time with a variable idle period between characters (0 to ∞). Each ASCII character is "framed" with a beginning start bit, an optional parity bit and one or more ending stop bits. The data format and baud rate must match that of other equipment in order for communication to take place. The figures list the data formats employed by the meter.

Start bit and Data bits

Data transmission always begins with the start bit. The start bit signals the receiving device to prepare for reception of data. One bit period later, the least significant bit of the ASCII encoded character is transmitted, followed by the remaining data bits. The receiving device then reads each bit position as they are transmitted. Since the sending and receiving devices operate at the same transmission speed (baud rate), the data is read without timing errors.

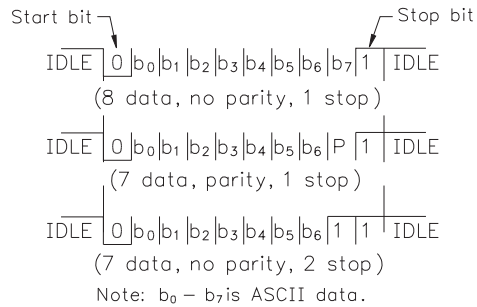

Character Frame Figure

Parity bit

After the data bits, the parity bit is sent. The transmitter sets the parity bit to a zero or a one, so that the total number of ones contained in the transmission (including the parity bit) is either even or odd. This bit is used by the receiver to detect errors that may occur to an odd number of bits in the transmission. However, a single parity bit cannot detect errors that may occur to an even number of bits. Given this limitation, the parity bit is often ignored by the receiving device. The PAX meter ignores the parity bit of incoming data and sets the parity bit to odd, even or none (mark parity) for outgoing data.

Stop bit

The last character transmitted is the stop bit. The stop bit provides a single bit period pause to allow the receiver to prepare to re-synchronize to the start of a new transmission (start bit of next byte). The receiver then continuously looks for the occurrence of the start bit.

MODULE 8 - ANALOG OUTPUT PARAMETERS (8-AnlOut)

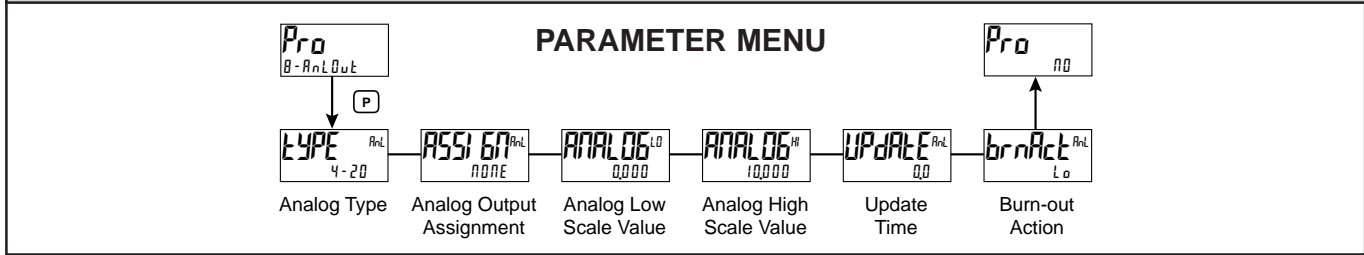

ANALOG OUTPUT TYPE



4-20 0-10 0-20

Enter the analog output type. For 0-20 mA or 4-20 mA use terminals 18 and 19. For 0-10 V use terminals 16 and 17. Only one range can be used at a time.

ANALOG HIGH SCALE VALUE



- 199999 to 999999

Enter the Display Value that corresponds to 20 mA (0-20 mA) , 20 mA (4-20 mA) or 10 VDC (0-10 VDC).

ANALOG OUTPUT ASSIGNMENT



NONE rEL Ab5 tOtAL Hi Lo
51 52 53 54

Enter the source for the analog output to retransmit:

rEL = Relative (net) Input Value. The Relative Input Value is the Absolute Input Value that includes the Display Offset Value.

Ab5 = Absolute (gross) Input Value. The Absolute Input Value is based on Module 1 dSP and INP entries.

tOtAL = Totalizer Value

Hi = Maximum Display Value

Lo = Minimum Display Value

51-54 = Setpoint Values

ANALOG UPDATE TIME



0.0 to 10.0

Enter the analog output update rate in seconds. A value of 0.0 allows the meter to update the analog output at the ADC Conversion Rate.

PROBE BURN-OUT ACTION



Hi Lo

Enter the probe burn-out action. In the event of a temperature probe failure, the analog output can be programmed for low or high scale.

ANALOG LOW SCALE VALUE



- 199999 to 999999

Enter the Display Value that corresponds to 0 mA (0-20 mA) , 4 mA (4-20 mA) or 0 VDC (0-10 VDC).

MODULE 9 - FACTORY SERVICE OPERATIONS (9-FACtrY)

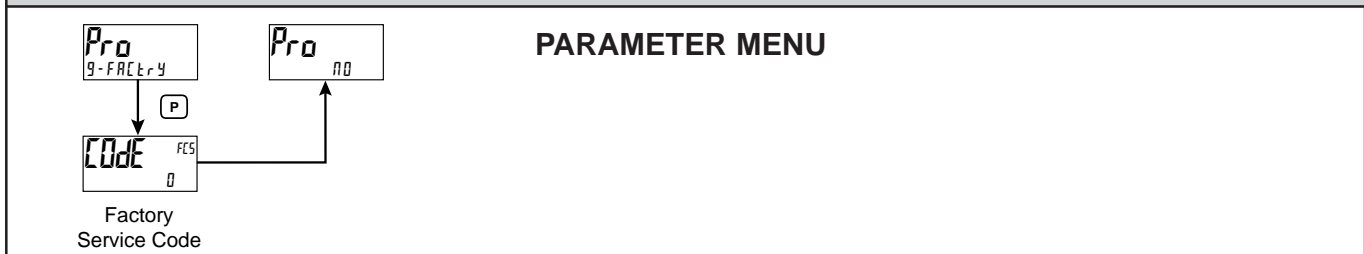

RESTORE FACTORY DEFAULTS



Use the arrow keys to display CODE 66 and press P. The meter will flash rESEt and then return to CODE 50. Press the P key to return to Display Mode. This will overwrite all user settings with the factory settings.

CALIBRATION



N0 Curr Volt OhmS
tC ICE rtd AnlOut

The meter has been fully calibrated at the factory. Scaling to convert the input signal to a desired display value is performed in Module 1. If the meter appears to be indicating incorrectly or inaccurately, refer to Troubleshooting before attempting to calibrate the meter. When recalibration is required (generally every 2 years), it should only be performed by qualified technicians using appropriate equipment. Calibration does not change any user programmed parameters. However, it may affect the accuracy of the input signal values previously stored using the Apply (APPLY) Scaling Style.

Calibration may be aborted by disconnecting power to the meter before exiting Module 9. In this case, the existing calibration settings remain in effect.

MODEL AND CODE VERSION



The meter will display the model (P2R) on Line 1, and the code version (UER x.xx) on Line 2.

LIMITED WARRANTY

The Company warrants the products it manufactures against defects in materials and workmanship for a period limited to two years from the date of shipment, provided the products have been stored, handled, installed, and used under proper conditions. The Company's liability under this limited warranty shall extend only to the repair or replacement of a defective product, at The Company's option. The Company disclaims all liability for any affirmation, promise or representation with respect to the products.

The customer agrees to hold Red Lion Controls harmless from, defend, and indemnify RLC against damages, claims, and expenses arising out of subsequent sales of RLC products or products containing components manufactured by RLC and based upon personal injuries, deaths, property damage, lost profits, and other matters which Buyer, its employees, or sub-contractors are or may be to any extent liable, including without limitation penalties imposed by the Consumer Product Safety Act (P.L. 92-573) and liability imposed upon any person pursuant to the Magnuson-Moss Warranty Act (P.L. 93-637), as now in effect or as amended hereafter.

No warranties expressed or implied are created with respect to The Company's products except those expressly contained herein. The Customer acknowledges the disclaimers and limitations contained herein and relies on no other warranties or affirmations.

Red Lion Controls
Headquarters
20 Willow Springs Circle
York PA 17406
Tel +1 (717) 767-6511
Fax +1 (717) 764-0839

Red Lion Controls
Europe
Printerweg 10
NL - 3821 AD Amersfoort
Tel +31 (0) 334 723 225
Fax +31 (0) 334 893 793

Red Lion Controls
India
54, Vishvas Tenement
GST Road, New Ranip,
Ahmedabad-382480 Gujarat, India
Tel +91 987 954 0503
Fax +91 79 275 31 350

Red Lion Controls
China
Unit 101, XinAn Plaza
Building 13, No.99 Tianzhou Road
ShangHai, P.R. China 200223
Tel +86 21 6113-3688
Fax +86 21 6113-3683