



Shawnee II Digital Programmable Timer

A compact version of the versatile 333 Timer, the **ATC 353B** is its exact functional duplicate. Packaged in a 72mm² DIN-Size housing, it occupies 40% less panel space and costs proportionately less. Modern production and assembly techniques have all but eliminated hand wiring, enhancing the reliability and life expectancy of the 353B.

CONTROL VERSATILITY: The 353B operates either as a repeat cycle pulse generator or in single-cycle interval or delayed mode. You choose the kind of control action you want by installing jumpers on the terminal block. It also provides a choice of control output. Choose a standard plug-in SPDT relay or optional SPST solid-state switch module plus an independent-24VDC output signal at Terminal 16.

COMPUTER TESTED RELIABILITY: The solid-state 353B is manufactured from a series of computer-tested plug-in circuit boards and assembled virtually without hand wiring. Because it has no moving parts in its logic circuits, its life expectancy is practically unlimited. Even the load relay — the 353B's only significant mechanical component — has a life expectancy of 100,000,000 operations (no load), while the optional solid-state switch module has virtually unlimited life expectancy. As a result, the 353B achieves an overall reliability that surpasses even the high level achieved by previous Shawnee timers.

SAVE 40% IN PANEL SPACE AND COST: Packaged in a 72mm² DIN-size housing, the 353B occupies 40% less panel space than previous IC timers. Modern production and assembly techniques have substantially reduced manufacturing costs and resulted in a 45% cost saving.

WIDE RANGE: Each Shawnee II 353B timer covers the overall span of 0.01 SEC to 999.9 MIN in four field-convertible ranges.

EASY TO SET: The Shawnee timer is easily and accurately set even with work gloves on. Push any of its four toggle levers in any sequence until the number you want appears above it. You can decrease as well as increase each number by pushing the levers up or down. You can change the setting at any time, even during a cycle.

NOISE IMMUNITY: The 353B does not have to be shielded: its transformer power supply, full-wave bridges, buffered logic and other design characteristics render it immune to the electrical noise that is sometimes encountered in industrial environments thus eliminating false starts and reset due to voltage spikes.

CYCLE PROGRESS INDICATION: The Shawnee 353B indicating timer provides cycle progress indication on a four-digit display located immediately above the digital setting number wheels. While the non-indicating Model 353B does not provide true cycle progress indication, it has a pilot light which is on during the timing cycle and a legend light which is on when there is power to the timer.

OUTSTANDING REPEAT ACCURACY: Unsurpassed among industrial timers regardless of cost, the Shawnee 353B has a repeat accuracy of ± 10 milliseconds on any setting within its overall range of 999.9 MIN, even in the face of wide swings in temperature or voltage and regardless of the amount of reset time between cycles.

PLUG-IN AND DUST-TIGHT: All 353B timers feature true plug-in design and are dust-tight from the front of panel.

MODEL NUMBER >>>>>	353B		30	P
	Range			
	999.9 SEC	346		
	999.9 MIN	347		
	99.99 SEC	351		
	99.99 MIN	352		
	Special	000		
	Voltage & Frequency			
	120/60	A		
	240/60	B		
	120/50	C		
	240/50	D		
	Arrangement			
	With Display (on Delay)	30		
	Features			
	Basic plug-in unit	P		
	Standard unit	X		
	With solid-state output module	J		
	Special	K		
ACCESSORIES:	0353-260-27-00: Surface mounting bracket kit 0305-265-61-70: Retrofit kit			

The 353B Directly Replaces 353A.

SPECIFICATIONS

MODELS	Both indicating and non-indicating models of the 353B are available. See ordering code.		POWER REQUIREMENTS	120V	95 to 132V, 50/60 Hz inrush – 0.4 A running – 0.04 A			
RANGES	Four field convertible ranges		DC POWER SUPPLY OUTPUT (Terminal 7)	240V	190 to 264V, 50/60 Hz inrush – 0.2 A running – 0.02 A			
	0.01 - 99.99 SEC			Voltage	-24V ± 10%			
	0.01 - 99.99 MIN				Current	40 mA max.		
	0.1 - 999.9 SEC				Voltage	ON – -24V ± 10% OFF – -1V or less		
0.1 - 999.9 MIN		Current	with relay–5 mA max. without relay–40 mA max					
TIMING MODES	Single cycle (interval or delayed) and repeat cycle pulse generator.		DC OUTPUT (Terminal 16)	Impedance	on – 10 ohms max. off – 10K ohms.			
<i>VOLTAGE REQUIREMENTS</i>				PULSE GENERATOR OPERATION	PULSE ON TIME(with relay): 80 mSEC ± 20 mSEC (may be shortened or lengthened by installing a resistor or capacitor, respectively, across Terminals 4 and 11; see Operation Section for details.)			
START/RESET SIGNAL	Positive Polarity	Ready at 4.5V min. Reset at 1.0V max.	LOAD RELAY		LIFE 100,000,000 operations (no load.) CONTACT RATING: 5A at 120V AC			
	Negative Polarity	Ready at 3.0V min. Reset at 1.0V max			SOLID-STATE SWITCH MODULE (OPTIONAL)	Switches external DC voltage supply of positive polarity, 4 to 30V, 50 mA max. (details of operation described in installation manual.)		
	Max. Continuous Input	40V.				REPEAT ACCURACY	±0.01 SEC on all ranges.	
	Ripple Voltage	must not go below minimum required					MINIMUM SETTING	99.99 SEC or MIN ranges: 0.01 SEC or MIN, respectively. 999.9 SEC or MIN ranges: 0.1 SEC or MIN, respectively.
	AC Line Voltage Input Impedance	5K ohms.			MOUNTING ACCESSORIES			Standard
	<i>RESET TIME</i>			Optional		Surface mounting without and with front-facing terminals. (See Accessory section of catalog)		
	Circuit Reset	1 mSEC max.	LATCHING MODE OPERATION (interval only)	NEMA 12	NEMA 12 case (1 timer)			
	Relay Drop-Out	20 mSEC max.		WEIGHT	NET: 1 lb., 7 oz. SHIPPING: 2 lbs.			
	<i>START SWITCH REQUIREMENTS (isolated contact)</i>							
	Switch Rating	10mA 30V	TEMPERATURE RATING	32° to 140°F (0 to 60°C)				
Min Open Resistance	1 megohm							
Max. Closed Resistance	20K ohms							

WIRING

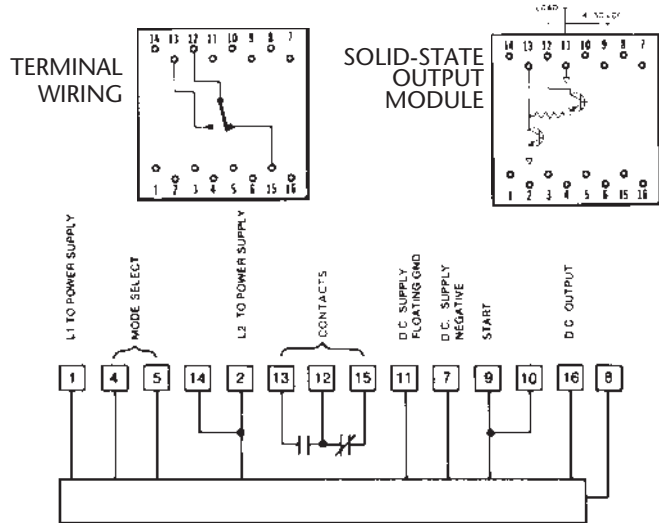

DIMENSIONS (INCHES)

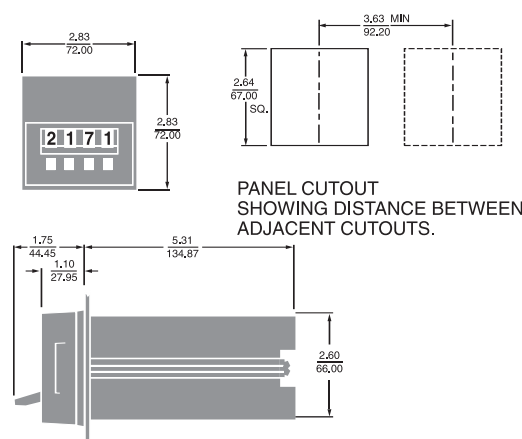

OPERATION

The Shawnee 353B operates on a digital logic circuit with three main elements: a clock which uses utility line frequency of 50 or 60 Hz as its time base; a read-only-memory (ROM) whose output is set by the timer's digital setting number wheels; and a comparator that continuously examines the outputs of the clock and ROM.

When power is applied (start signal on), the clock begins to count each cycle of the utility line frequency. Translating this count into hundredths of a second, the clock accumulates it and feeds it continuously to the comparator. When clock output exactly equals the output of the ROM, the 353B times out.

At that instant, the clock turns itself off automatically.

At the same instant, the 353B generates one type of control action or another, depending on how it is wired.

When the 353B is wired for interval operation, the timer's output device (either the standard SPDT relay or the optional SPST switch module) is energized from the start to the end of the time cycle; so is the -24 VDC output at terminal 16.

When the 353B is wired for delayed control, the output device is energized at the end of the cycle and remains on until the timer is reset; so is the -24 VDC output. When the 353B is wired as a repeat cycle pulse generator, the output device and the DC signal are both off until the end of the cycle, at which time they are both on for about 80 mSEC. The length of the pulse is included in the time cycle: the cycle runs from the start of one pulse to the start of the next. The 353B automatically starts a new cycle immediately after reset.

The duration of the standard output pulse generated by the 353B is 80 mSEC (± 20 mSEC), but it can be easily lengthened or shortened by using a capacitor or resistor across terminals 4 and 11.

To shorten the output pulse, the size of the resistor (fixed or variable) is calculated as follows:

Where: t = time in milliseconds ($\pm 25\%$)

$$R = \frac{2.2t - 2.64}{80 - t} = R$$

(must be at least 0.2 megohm.)

To lengthen the output pulse, the size of the capacitor is calculated as follows:

Where: T = time in seconds ($\pm 25\%$)

$$C = \frac{T - 0.08}{1.6} = C$$

C = capacitance in microfarads.

NOTE Observe Polarity: + Terminal of the capacitor goes to 11, - Terminal to 4. To start from AC voltage, jumper terminals 8-9 and 4-11 and start with AC power at terminals 1 and 2.

TYPICAL INSTALLATION

DELAYED MODE — Sustained* start

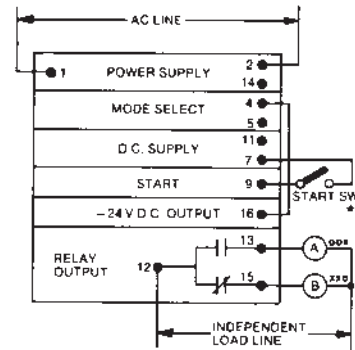

INTERVAL MODE — Sustained* or momentary** start

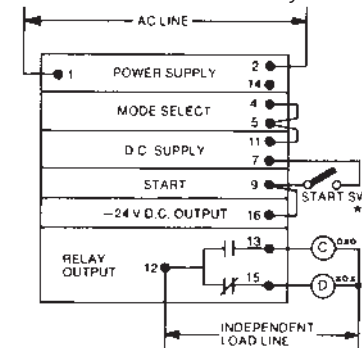

INTERVAL MODE — Sustained* start

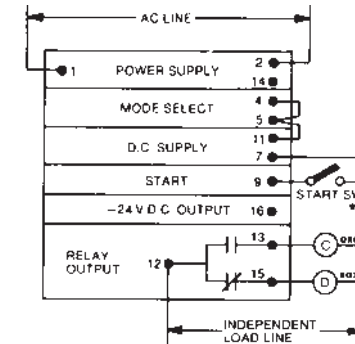

REPEAT CYCLE PULSE GENERATOR — Uninterrupted start signal

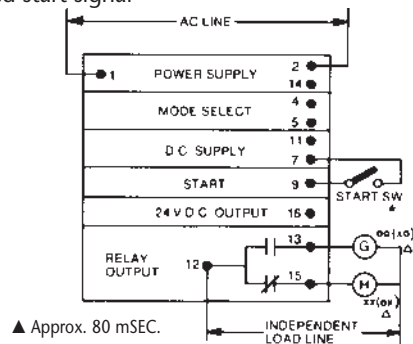

*Start switch must be closed — or DC start signal must be on — for entire cycle. Timer resets when start switch opens or DC start signal turns off. To start from DC voltage, apply external ground on 11 and start signal on 9.

**Start switch may be closed — of DC start signal may be on — for less that the entire cycle. Timer resets at end of cycle.

A compact version of the 335 Timer, the **ATC 355B** is its exact functional duplicate, packaged in a 72mm² DIN-Size housing, it occupies 40% less panel space and costs proportionately less. Modern production and assembly techniques have all but eliminated hand wiring, enhancing the reliability and life expectancy of the 355B.

COMPUTER TESTED RELIABILITY: The Solid-State 355B is manufactured from a series of computer-tested plug-in circuit boards and assembled virtually without hand wiring. Because it has no moving parts in its logic circuits, its life expectancy is practically unlimited. Even the load relay — the 355B's only significant mechanical component — has a life expectancy of 100,000,000 operations (no load). As a result, the 355B achieves an overall reliability that surpasses even the high level achieved by previous Shawnee timers.

CYCLE PROGRESS INDICATION: The Shawnee indicating timer provides cycle progress indication on a four-digit display located immediately above the digital setting number wheels.

PLUG-IN AND DUST-TIGHT: All 355B timers feature true plug-in design and can be replaced in seconds without disturbing the housing or disconnecting the wiring. The dial assembly is gasketed so that the timer body is dust-tight from the front of panel.

WIDE RANGE: Each Shawnee 355B timer covers the overall span of 0.01 SEC to 999.9 MIN in two field-convertible ranges. The 355B indicating timer also offers two additional field-convertible ranges of 0.1-999.9 SEC or MIN

EASY TO SET AT ALL TIMES: The Shawnee timer is easily and accurately set even with work gloves on. Push any of its four toggle levers in any sequence until the number you want appears above it. You can decrease as well as increase each number by pushing the levers up or down. You can change the setting at any time, even during a cycle.

SAVE 40% IN PANEL SPACE AND COST: Packaged in a 72mm² DIN-size housing, the 355B occupies 40% less panel space than previous IC timers. Modern production and assembly techniques have substantially reduced manufacturing costs and resulted in a 45% cost saving.

OUTSTANDING REPEAT ACCURACY: Unsurpassed among industrial timers regardless of cost, the Shawnee has a repeat accuracy of ±10 milliseconds on any setting within its overall range of 999.9 MIN, even in the face of wide swings in temperature or voltage and regardless of the amount of reset time between cycles.

NOISE IMMUNITY: The 355B does not have to be shielded: its transformer power supply, full-wave bridges, buffered logic and other design characteristics render it immune to the electrical noise that is encountered in typical industrial environments.



Shawnee II Digital Reset Timer

MODEL NUMBER >>>>>>	355B		30 P
	Range		
	999.9 SEC	346	
	999.9 MIN	347	
	99.99 SEC	351	
	99.99 MIN	352	
	Special	000	
	Voltage & Frequency		
	120/60	A	
	240/60	B	
	120/50	C	
	240/50	D	
	Arrangement		
	With Display (on Delay)	30	
	Features		
	Basic plug-in unit	p	
	Standard unit	X	
	Special	K	
ACCESSORIES			
0353-260-27-00:	Surface mounting bracket kit		
0305-265-61-70:	Retrofit kit		

THE 355B DIRECTLY REPLACES 355A.

SPECIFICATIONS

RANGES	0.01 - 99.99 SEC	
	0.01 - 99.99 MIN	
	0.1 - 999.9 SEC	
	0.1 - 999.9 MIN	
	field-convertible	
TIMING MODES POSSIBLE	Single Cycle	interval or delay
	Repeat Cycle	pulse (fixed at approx. 50 mSEC)
CYCLE PROGRESS INDICATOR	4 digit, 0.3 inch, high intensity, blue display	
REPEAT ACCURACY	±0.01 SEC on all ranges	
RESET TIME	75 milliseconds	
MINIMUM SETTING	99.99 SEC of MIN ranges: 0.01 SEC or MIN, respectively	
	999.9 SEC or MIN ranges: 0.1 SEC or MIN, respectively	
LOAD RELAYS	Number	two, one instantaneous and one delayed; both plug-in DPDT
	Operate Time	20 mSEC, max.
	Release Time	instantaneous — 20 mSEC, max. delayed — 75 mSEC, max.
	Contact Rating	5 A at 120 VAC,
	Life	100 million operations (no load)
TEMPERATURE RATING	32° to 140°F (0 to 60°C)	
POWER REQUIREMENTS	120V	95-132V at 50 or 60 Hz inrush — 0.2 A running — 0.04 A
	240V	190-264V AT 50 OR 60 Hz inrush — 0.1 A running — 0.02 A
	Clock Input	
	Voltage	95-132V rms (120V Model) 190-264V rms (240V Model)
	Current	20 mA max.
	Frequency	0 to 1000 Hz (sinusoidal)
	TERMINALS	16 screw terminals accessible at rear; integral wiring diagram on housing
HOUSING	Plug-in design; completely gasketed, dust-tight when panel-mounted	
MOUNTING ACCESSORIES <small>See Accessory section of catalog</small>	Standard	Hardware is provided to mount timer so that it is dust-tight from front of panel
	Optional	Surface mounting without and with front-facing terminals
	NEMA 12 case (1 timer)	
WEIGHT	NET: 1 lb., 7 oz.	SHIPPING: 2 lbs

OPERATION

The Shawnee 355B operates on a digital logic circuit with three main elements: a clock which uses utility line frequency of 50 or 60 Hz as its time base; a read-only-memory (ROM) whose output is set by the timer's digital setting number wheels; and a comparator that continuously examines the outputs of the clock and ROM.

When power is applied (start signal on), two things happen simultaneously; the instantaneous DPDT relay is energized transferring both sets of contact, and the clock circuit begins to count each cycle of the utility line frequency. Translating this count into hundredths of a second, the clock accumulates it and feeds it continuously to the comparator. When clock output exactly equals the output of the ROM, the comparator causes the 355B to time out.

At this point, (1) the DPDT delay relay is energized, immediately transferring both sets of contacts and (2) the clock turns itself off automatically. Since the clock stops counting even if the start signal remains on, it is not necessary to tie up one of the 355B's delayed contacts to do this job.

To reset the Shawnee 355B, power must be removed from terminal 1 (L1) for 75 milliseconds or more. The 355B operates in the On-Delay mode only, always resetting whenever there is a power outage and starting a new cycle when power is restored.

CYCLE PROGRESS INDICATION: When the timer is in the reset condition, the LED display is blank. During the timing cycle, the display counts up from zero, thus always indicating the amount of time that has elapsed since the start of cycle. At time-out, the display shows total elapsed time and exactly equals the numbers on the digital setting wheels.

		Switching Sequence: Assumes a sustained closed start signal (i.e. longer than the setting on the digital display.)		
RELAY	CONTACTS	Before Start	During Timing	End of Cycle
Instantaneous	14-9/6-8	BLACK	GRAY	GRAY
	14-10/6-7	GRAY	BLACK	GRAY
Delayed	11-12/4-5	BLACK	GRAY	BLACK
	11-13/4-3	GRAY	BLACK	BLACK

BLACK-Circuit Closed
 GRAY-Circuit Open

TYPICAL INSTALLATIONS

KEY SYMBOLS

- POWER SUPPLY
 - CLOCK
 - INDEPENDENT LOADS
 - DEPENDENT LOADS
 - MOMENTARY STARTING CONTACT
 - SUSTAINED STARTING CONTACT
 - LOAD ENERGIZED
 - LOAD DE-ENERGIZED
- All timers shown in "before start" position. Diagrams shown with power off unless otherwise marked.
- Maximum load current through any load carrying contact is 5 amperes. Pilot lights leads are brought out to terminal block. Pilot light can be wired to show practically any desired function timer energized, cycle running instantaneous or delayed switch closed. etc.

- DELAYED CONTACTS
Contacts transfer simultaneously when unit "times out" and all digits are zero.
- INSTANTANEOUS CONTACTS
Contacts are transferred when power supply is energized, transferred back as shown when de-energized.

DIMENSIONS (INCHES/MILLIMETERS)

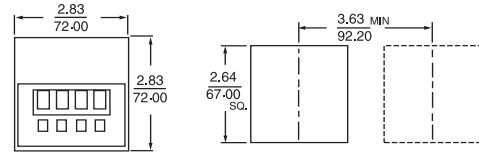

PANEL CUTOUT SHOWING DISTANCE BETWEEN ADJACENT CUTOUTS.

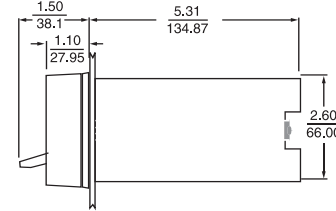

SUSTAINED START

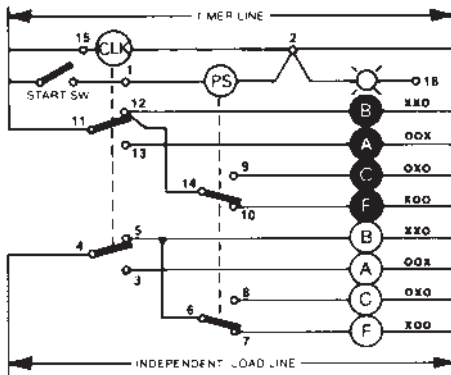

MOMENTARY START

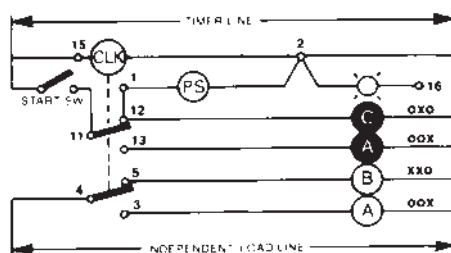
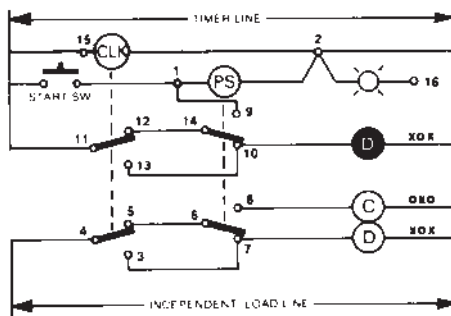

WIRING

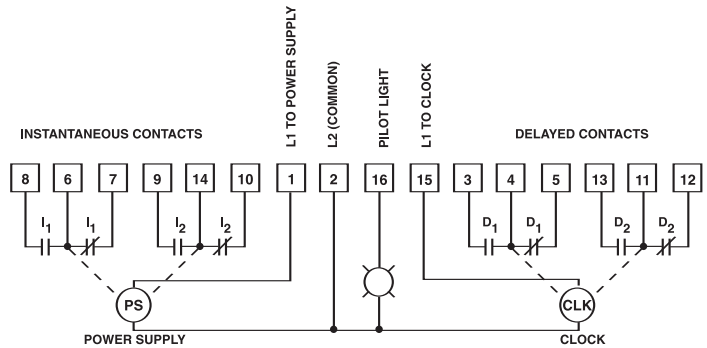

Pilot light only on unit without display

TERMINAL WIRING: INDICATING MODEL

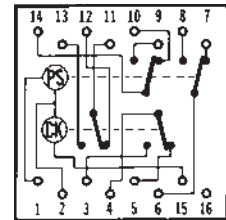

Panel Mounted Digital Timers // 355B Series



LONG-RANGER Computing Timer

The ATC 365B Timer is microprocessor-based digital timer with three rotary knobs for setting and adjustment of the Preset. The Preset can be any three-digit value from .01 SEC to 999 HR. The Decimal and Range are switch selectable. The high-intensity blue vacuum fluorescent display is DIP switch selectable to Timeup or Timedown. Two heavy-duty 7A DPDT relays provide instantaneous, interval or delayed output control. Plug-in panel mounting allows easy replacement without the removal of field wiring.

COMPUTATION: Through its internal microcomputer, the 365B keeps track of the set point throughout the time cycle. Whenever there is a change in set point, even during a cycle, it instantly re-computes the time remaining and accurately determines time-out. This unique capability is especially valuable in the time-down modes as it allows you to shorten a cycle without loss of accuracy.

POSITIVE RESET TIME AND PULSE LENGTH: Digitally clocked by the micro-computer, the 365B's reset time is consistently of the same duration, regardless of variations in line voltage, power supply or time cycle. As a result, the 365B is not subject to false reset from momentary power interruptions (less than 30 mSEC). When the 365B operates in repeat-cycle mode, the output pulse is also digitally clocked so that both its occurrence and duration are consistent.

WIDE RANGE: Each 365B Long-Ranger covers the overall span of 0.01 SEC to 999 HR, in nine switch-selected ranges of 0 to 9.99,99.9 or 999 SEC, MIN or HR. The timer can be optimized within any selected range simply by removing appropriate selector knobs (e.g. with the timer in the 9.99 SEC range, you can obtain a tamper-proof span of 0.99 by setting the left selector at 0 and removing the knob).

PROGRAMMABLE DISPLAY: Depending on the position of an internal jumper, the 365B's three-digit cycle progress display will time UP to or DOWN from the set point; after time-out, it will either STOP or GO (i.e. display the time elapsed after time-out). To the right of the three-digit display, a timing bar "■" blinks once per second during the timing cycle and rapidly after time-out. At left, a marker "▼" turns on when the delayed relay is energized. The 365B is also available without display but with a pilot light that blinks once per second during the cycle and rapidly after time-out.

NOISE IMMUNITY: The 365B has formidable defenses against noise: transformer power supply, full-wave bridges, buffered logic. Furthermore its microcomputer detects; and rejects; noise pulses that manage to penetrate its defenses. No industrial timer has ever offered greater noise immunity.

RELIABILITY AND RUGGEDNESS: ATC firmly believes that no industrial timer has ever achieved a higher level of reliability and ruggedness. The 365B's electronic components have no moving parts and are assembled, virtually without hand wiring, from computer-tested circuit boards. Its few mechanical components have been selected for reliable service; the two load relays have a life expectancy of 100,000,000 operations and heavy-duty contacts rated at 7 amps; and the three rotary set point selector switches exhibit extremely low wear.

COMPACT, PLUG-IN AND DUST-TIGHT: Packaged in a 72mm² DIN housing, the 365B occupies 40% less panel space than conventional timers. It is a true plug-in timer that can be replaced in seconds without disturbing housing or wiring. The 365B is also fully gasketed and O-ring sealed to be dust and water-tight.

SELF DIAGNOSTICS: The time will display "FAIL" anytime there is a problem or the knobs are in between digits.

DIMENSIONS (INCHES/MILLIMETERS)

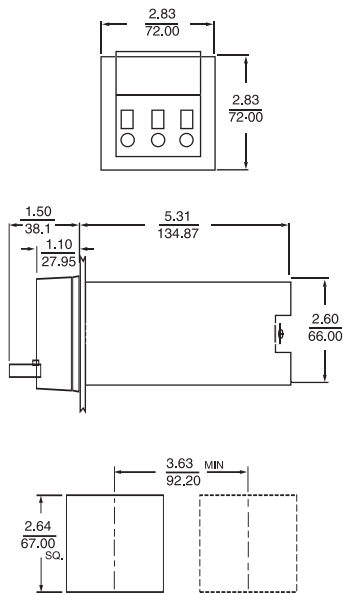

PANEL CUTOUT
SHOWING DISTANCE BETWEEN
ADJACENT CUTOUTS.

SPECIFICATIONS

MODELS	Arrangement "30," with digital display available for On-Delay operation at 120, 240 or 24 VAC; and 24, 48 or 125 VDC		120 VAC	95-132 VAC, 50 or 60 Hz. Inrush — .3A. Running 0.06A at 120 VAC
RANGES	Switch-selectable ranges of 0-9.99, 0-99.9 and 0-999 SEC, MIN or HR		240 VAC	90-264 VAC, 50 or 60 Hz. Inrush — .15A. Running — 0.03A at 240 VAC
TIMING MODES	Single Cycle	interval or delayed.	24 VAC	19.2-26.4 VAC, 50 or 60 Hz Inrush — 1A. Running — 0.25A at 24 VAC
	Repeat Cycle	pulse-clocked at 50 to 80 mSEC (will be constant for a given unit)	24 VDC	19.2-26.4 VDC, 5% ripple Running — .120A AT 24 VDC
RESET TIME	Clocked at 60 mSEC		Number	one instantaneous and one delayed
DISPLAY CYCLE PROGRESS	3 digit display, 0.3 inch, high-intensity, blue programmable: DOWN and STOP, DOWN and GO, UP and STOP or UP and GO		Type	DPDT, Form C.
	TIME-OUT	▼ display (left); energized at time-out.	Operate Time	P 13 mSEC, max.
TIMING BAR	display (right); blinks once per second during cycle, rapidly after time-out.		Release Time	10 mSEC, max.
CLOCK INPUT VOLTAGE MODEL	120VAC Model	95-132VAC, 10mA max. current at 120V	Contact Ratings	7A at 120, 240 or 24 VAC 1/6 HP
	240VAC Model	190-264VAC, 10 mA max. current at 240V	Life	100 million operations (no load)
	24VAC Model	19.2-26.4VAC, 20 mA max. current at 24V	REPEAT ACCURACY SETTING ACCURACY	± .001% ±.010 SEC of setting
	24VDC Model	19.2-26.4VDC (5% ripple), 5 mA max. current at 24V	SETTING ACCURACY	±.01% + .030 SEC of setting
	125 VDC Model	19.2 to 26.4 VDC 50mA DC Max.	TERMINALS	16 screw terminals accessible at rear
	125 VDC	100 to 150 VDC 15mA DC	HOUSING	72mm ² DIN size; plug-in design; fully gasketed, dust and water-tight in panel mounted installations.
TEMPERATURE RATING	32 to 140°F (0 to 60°C)		MOUNTING ACCESSORIES (See Accessory section of catalog)	Standard hardware is provided for front-of-panel mounting. Optional Surface-mounting brackets with front-facing terminals. NEMA 12 molded case (1 timer)
POWER REQUIREMENTS			WEIGHT	NET: AC 1 lb., 6 oz., DC 14 oz. Shipping: AC 2 lbs. DC 1 lb., 8 oz.

WIRING

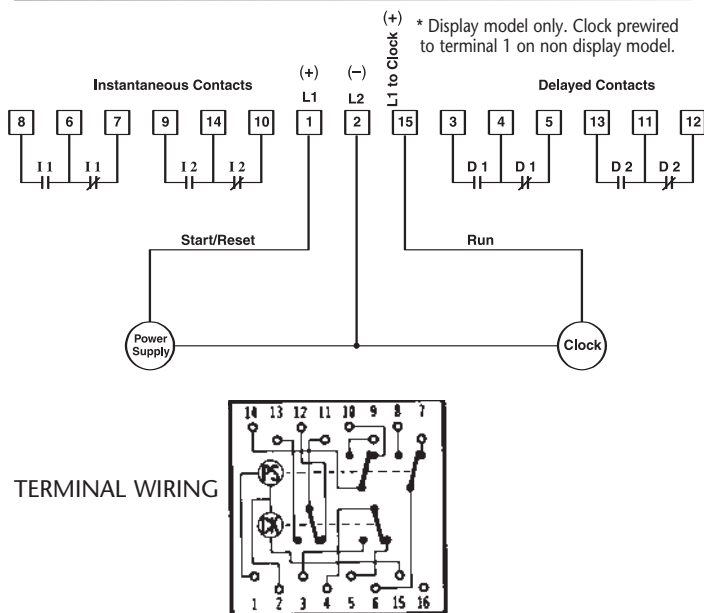

MODEL NUMBER >>>>>	365B	P
Range	0 to 9.99, or 99.9 or 999 SEC, MIN, or HR	
Special	300	
Voltage & Frequency	125 VDC	L
	24 VDC	N
	120 VAC 50-60 Hz	Q
	240 VAC, 50-60 Hz	R
	24 VAC, 50-60 Hz	T
Special	K	
Arrangement	With display, on-delay/Time up or down and stop (reset on power failure)	30
	Time up or down and go	50
Features	Basic plug-in unit	p
	Standard unit	X
	Special	K
ACCESSORIES	0353-260-27-00: Surface mounting bracket kit	
	0305-265-61-70: Retrofit kit	

Panel Mounted Digital Timers // 365B Series

OPERATION

As soon as power is applied to terminals 1 & 2 of the timer, the instantaneous relay is energized and changes the states of its associated contacts (8-6-7 & 9-14-10). The timer then looks for terminal 15 (the clock terminal) to receive power. When terminal 15 is powered, the internal clock circuit is enabled and the timer starts to time. When the internal clock time equals the time set on the front face, the delayed relay energizes and changes the states of its associated contacts (3-4-5 & 13-11-12). The timer is reset by removing power from terminal 1 for at least 60 msec. At reset, both relays revert back to their shelf (without power) state.

SPECIAL NOTE FOR UNITS WITHOUT DISPLAYS: On non-display units, terminals 1 & 15 are jumpered together internally. As soon as power is applied, the instantaneous relay energizes and the timer starts to time immediately.

DISPLAY INFORMATION: The digital display can be set to operate in any of 4 modes by simply moving a jumper on the circuit board.

MODE:

- UP & STOP (30PX Time up to time set, transfer delayed relay, and stop timing).
- UP & GO (50PX Time up to time set, transfer delayed relay, and continue timing until unit is reset).
- DOWN & STOP (30PX Time down to zero from time set, transfer delayed relay, and stop timing).
- DOWN & GO (50PX Time down to zero from time set, transfer delayed relay, and continue timing up from zero giving a direct overshoot reading. Timing will continue until unit is reset). All 365B timers are shipped from the factory in the UP & STOP mode.

TYPICAL INSTALLATIONS

KEY SYMBOLS

- PS POWER SUPPLY
- CLOCK
- INDEPENDENT LOADS
- DEPENDENT LOADS
- MOMENTARY STARTING CONTACT
- SUSTAINED STARTING CONTACT
- X LOAD ENERGIZED
- O LOAD DE-ENERGIZED

All timers shown in "before start" position. Diagrams shown with power off unless otherwise marked.

Maximum load current through any load carrying contact is 7 amperes.

ON DELAY Reset on power failure.

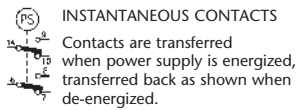
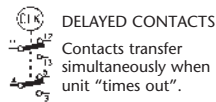

SUSTAINED START

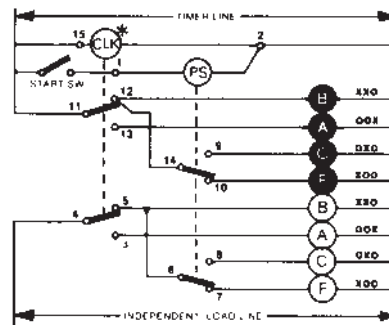

MOMENTARY START

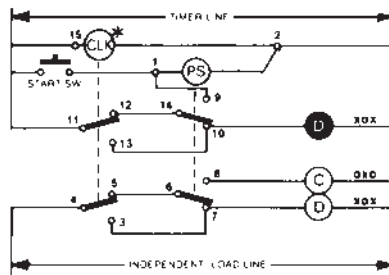

REPEAT CYCLE PULSE

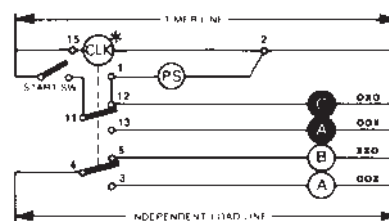

Load A pulses on for approximately 50 msec.

Packaged in a 72mm² DIN housing, the ATC 365M is a true plug-in timer that can be replaced in seconds without disturbing the mounting housing or field wiring. Machine and process downtime is kept to a minimum. The 365M is also fully gasketed and O-ring sealed to be dust tight.

WIDE RANGE: Each 365M timer covers the overall span of 0.01 SEC to 999 HR, in nine switch-selectable ranges of 9.99, 99.9, or 999 SEC, Min, or HR.

EASY-TO-ADJUST PRESET: ATC's unique three rotary switches for easy setting and adjustment of the preset time is an industry standard.

The switches can be adjusted anytime, even during a timing cycle. The timer is constantly scanning the preset setting and instantly re-computes the time cycle if a preset change is detected. This is especially valuable in the Timedown mode allowing you to shorten or abort the current time cycle without the removal of power.

SELF-CALIBRATING: The microprocessor automatically calibrates the timer for 50 or 60Hz power operation, there are no switches or jumpers to set.

PROGRAMMABLE DISPLAY: An internal DIP switch can be set for Timeup or Timedown and Stop display operation on the Arrangement 30 model. The Arrangement 50 model can be set for Timeup or Timedown and go.

There is a horizontal timing bar "■" which appears to the right of the display and blinks once per second during timing and rapidly at time-out. At left, a timed-out symbol "▼" blinks after time-out indicating when the magnetic delayed relay is latched.

MAGNETIC LATCH RELAY: The 365M utilizes a unique magnetic latch delayed relay which energizes, latches, at time-out. Once latched it will not unlatch even with power removed or the unit is unplugged from the housing. It will only unlatch when power is momentarily applied to the Reset, terminal 16.

NON-VOLATILE MEMORY: An EEPROM memory chip to retain the time value during a loss of power and continues timing when power is restored. No battery is required.

OPERATION

Arrangement 30 & 50 Models

When power is applied to terminals 1 & 2 and 15 of the timer, the instantaneous relay is energized and its contacts change state. The timer starts timing, indicated by the display. The timing bar "■" blinks slowly and the digital display indicates elapse time (Timeup & Stop) or time remaining (Timedown & Stop).

When the preset value is reached, the display stops, the timing bar blinks rapidly, the triangular timed-out symbol "▼" blinks, and the delayed relay latches and its contacts change state. The timer remains in this timed-out condition until reset by applying power to the Reset terminal 16 for at least 60 msec. At reset, both relays revert back to their shelf state (without power).

Note 1: The delayed relay is a magnetic latch relay and once latched it will not unlatch even if power is removed or the unit is unplugged from the housing. It will only unlatch when power is momentarily applied to the Reset terminal 16.



Long-Range Computing Timer with Memory

- EEPROM Memory
- Magnetic Latching Relay
- Delayed & Instantaneous DPDT Contacts
- Switch Selectable SEC, MIN or HR Ranges
- Nine Ranges 0 to 9.99, 99.9 or 999
- High Accuracy & Noise Immunity
- Easy Plug-In Housing
- High Intensity Blue Fluorescent Display
- Fully Gasketed and O-ring sealed to be dust and water-tight
- Timeup or Timedown Display Operation
- 50 or 60 Hz Operation Self-Adjusting

DIMENSIONS (INCHES/MILLIMETERS)

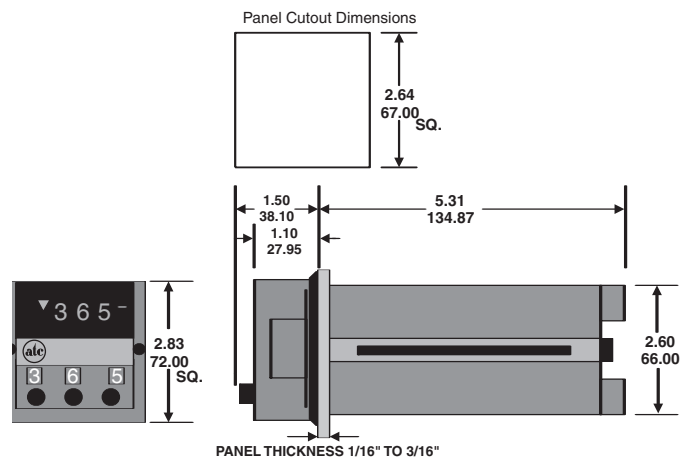

SPECIFICATIONS

MODELS	Choice of two standard 120 VAC models Each model available in 240 VAC or 24 VAC	
	365M300Q30PX	Timeup & Stop or Timedown & Stop, with display.
	365M300Q50PX	Timeup & Go or Timedown & Go, with display.
RANGES	Nine (9) Switch-Selectable ranges 0 - 9.99, 0 - 99.9, and 0 - 999 SEC, MIN, or HR	
MEMORY RETENTION	100,000 read/write cycles	
RESET TIME	Guaranteed not to reset <20 mSEC	
	Typical reset = 40 mSEC	
	Guaranteed to always reset >60 mSEC	
DISPLAY	Cycle Progress 3-digit high-intensity blue VF display, 0.3 inch Timing Bar: "■" display; blinks once per second during timing, rapidly after time-out.	
	Timed-Out Symbol: "▼", blinks after time-out, blinks when latch relay is latched	
LOAD RELAYS	Type	DPDT, Form C
	Contact Rating	7 Amps @ 120 VAC, or 1/6HP @ 240 VAC
	Operate & Release Time	10 mSEC max.
	Life	10 million operations (no load)
TEMPERATURE RATING	32°F to 140°F (0 to 60°C)	
POWER REQUIREMENTS	120 VAC	50 or 60 Hz (10%, -20%) Running <100mA @120VAC
	240 VAC	50 or 60 Hz (10%, -20%) Running <50mA @ 240 VAC
	24 VAC	50 or 60 Hz (10%, -20%) Running <300mA @ 24 VAC
CLOCK INPUT (Terminal 15)	120 VAC	95 - 132 VAC, 10 mA max. current @ 120V
	240 VAC	90 - 264 VAC, 10 mA max. current @ 240V
	24 VAC	19.2 - 26.4 VAC, 20 mA max. current @ 24V
TERMINALS	16 Screw (6-32) terminals with saddle clamps accessible at rear	
HOUSING	72mm ² DIN size, Plug-in design, fully gasketed dust and water-tight when panel mounted. Panel mounting bracket included.	
WEIGHT	Net: 1 lb. 6 oz	Shipping: 2 lbs.

WIRING

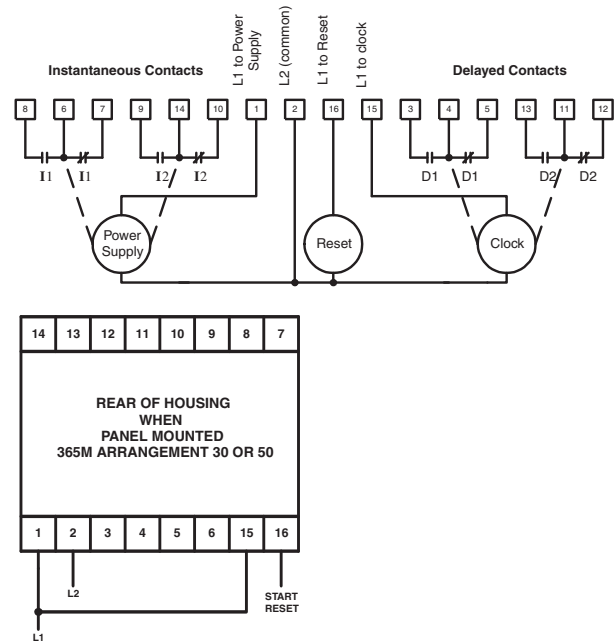

MODEL NUMBER >>>>>	365M				P
Range					
0 to 9.99, or 99.9 or 999 SEC, MIN, or HR		300			
Special		000			
Voltage & Frequency					
120 VAC 50-60 Hz		Q			
240 VAC, 50-60 Hz		R			
24 VAC, 50-60 Hz		T			
Special		K			
Arrangement					
Selectable Timeup & Stop or Timedown & Stop with Display, Standard		30			
Selectable Timeup & Stop or Timedown & Stop with Display, Non-Standard		35			
Selectable Timeup & Go or Timedown & Go with Display, Standard		50			
Selectable Timeup & Go with Display, Non-Standard		55			
Features					
Basic plug-in unit		p			
Standard unit		X			
Special		K			

In the timer mode, the 385 can be programmed to cover the overall span of 0.01 SEC to 999 HR in nine ranges, and can be programmed to time in Hours:Minutes and Minutes:Seconds. In the counter mode, it can cover the overall span of 1 to 99,900 counts in two ranges.

MULTIPLE RELAY ACTIONS: The relationship between the 385's two DPDT relays, Relay 1 and Relay 2 can be programmed for any of the four modes of operation to satisfy virtually any control scheme.

MULTIPLE STARTING OPTIONS: The 385 can be easily programmed to start with a momentary or sustained start signal. The start signal can also be set for a voltage or no voltage starting condition.

NEW TIMING AND COUNTING MODES: The 385 has two new modes of operation. The flip-flop timer/counter with batch, which can be programmed to function as a flip-flop that will stop after a certain number of cycles or a time span. The other new flip-flop function is a standard flip-flop with a programmable dwell between the relays.

DISPLAY: The display is an LED dual display which can be programmed to run UP to or DOWN from the set point. The lower display shows the preset selected to view and the upper display shows the cycle progress.

NON-VOLATILE MEMORY: The 385 retains its entire program and preset time/count periods even when there is a loss of power. No batteries are required.

REAL-TIME COMPUTATIONS: The 385's microcomputer instantly recomputes time/count-out when there is a change in the set point during a cycle. This allows you to shorten a cycle without loss of accuracy.

COMPACT, PLUG-IN AND DUST-TIGHT: Packaged in a 72mm² DIN housing, the 385 takes 40% less panel space than conventional timers. A true plug-in design, it can be replaced in seconds without disturbing housing or wiring. Fully gasketed and sealed, it is dust tight in panel mounted installations.

SETUP: Setup of the 385 is accomplished using 16 DIP switches which are located inside the unit. These DIP switches give a visual indication of how the Controller is setup, and eliminates the use of complex programming codes.



Timer/Counter with Memory

- EEPROM Memory
- Easy DIP Switch Setup
- Three Adjustable Presets with Internal Cycle Totalizer
- Dual LED Display with Cycle Progress
- Selectable SEC, Min., or Hrs., Ranges
- Nine Timing Ranges 0 to 9.99, 99.9, 999, or HR:MIN, MIN:SEC to 99:59
- Two Counting Ranges 0 to 9999 or 10 to 99990
- Multiple Starting Options
- Dual DPDT Relays Rated at 7A @ 120 or 240 VAC
- 50-60 Hz

DIMENSIONS (INCHES/MILLIMETERS)

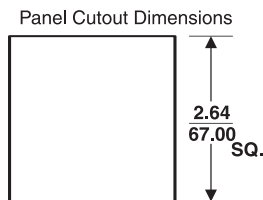
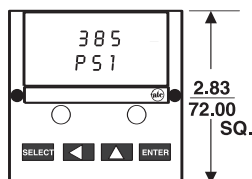
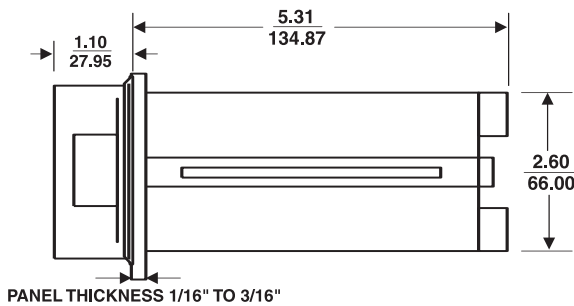

MODEL NUMBER >>>>>	385A	500	50	P
Range		500		
Voltage & Frequency				
	120 VAC	50-60 Hz	Q	
	240 VAC,	50-60 Hz	R	
Function				
	Programmable	50		
Features				
	Basic plug-in unit		P	
	Standard unit			X
	Special			K

Panel Mounted Digital Timers// 385A Series

DIP SWITCH SETUP

After you have setup the Controller by programming the DIP switches you must first set DIP switch (8) on the right bank to program mode, this allows you to set the presets 1, 2 and 3, in seconds, minutes, or hours. You must press the "select" button to choose the preset to select. To choose the time range you must select the timing bar "▬" and scroll to your time range. The seconds range is indicated by the timing bar in the top position, the minutes in the middle position and hours in the bottom position, when used as a counter it will display as a "C". After each selection is made you must press the "enter" button.

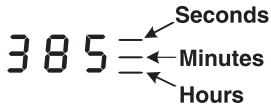

Preset 3 can be set up as a count or time input regardless if it is set up as a counter or a timer/counter in Flip-Flop with batch mode.

When setup as a standard timer (DIP switches 2 and 3 up on left bank) you may program the decimal point by scrolling past the left digit and press the up scroll button, this will place the decimal point in the 2 possible places, when finished press the "enter" button and set back to run mode. When the 385 is in the run mode the time from each preset can only be adjusted in the time range with the decimal position you chose while in the program mode.

For users who wish to have no changes allowed in the run mode – see DIP switch setup.

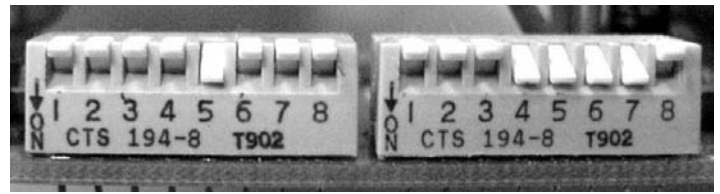

LEFT SWITCH

- 1 Up= Counter
Dn= Timer
- 2 Up= Counter or Standard Timer
Dn= Minutes:Seconds (Timer Only)
- 3 Up= Counter or Standard Timer
Dn= Hours:Minutes (Timer Only)
- 4 5 Up Up Display preset 1 (PS1)
Up Dn Display preset 2 (PS2)
Dn Up Display preset 3 (PS3)
Dn Dn Display preset 4 Totalizer (PS4)
- 6 Up= Count/Time Down
Dn= Count/Time Up
- 7 Up= Changes in run mode allowed
Dn= No Changes in run mode allowed
- 8 Up= (Normal) X 1
Dn= X 10 prescaler (Counter Only)

RIGHT SWITCH

- 1 Up= Non-Memory (reset on power failure)
Dn= Memory (no reset on power failure)
- 2 Up= Repeat Cycle
Dn= Single Cycle
- 3 Up= Momentary Start
Dn= Sustained Start
- 4 Up= Voltage Start (close to start, open to reset)
Dn= No Voltage Start (open to start, close to reset)
- 5 6 Up Up Relay Arrangement # 1
Up Dn Relay Arrangement # 2
Dn Up Flip Flop with Dwell
Dn Dn Flip Flop with Batch
- 7 Up= Normal Operation
Dn= Self Test**
- 8 Up= Program Mode
Dn= Run Mode

4 MODES OF OPERATION

RELAY ARRANGEMENT 1

Relay 1 energizes before Relay 2 and remains energized when Relay 2 energizes. Both relays drop out simultaneously.

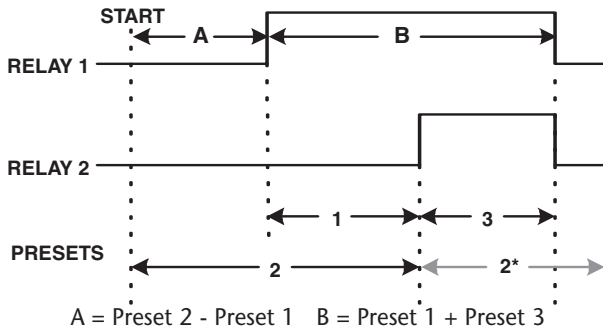

RELAY ARRANGEMENT 2

Relay 1 energizes before Relay 2 and drops out when Relay 2 energizes.

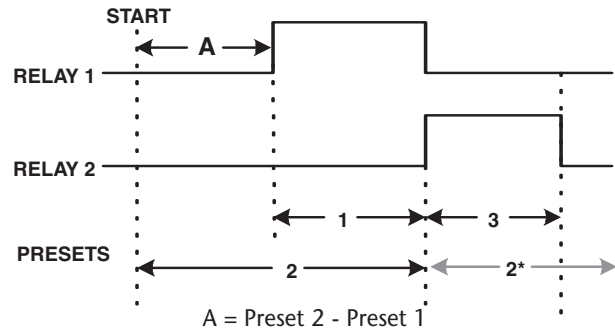

FLIP FLOP TIMER OR COUNTER WITH BATCH

Relay 1 energizes at start and drops out when Relay 2 energizes. Stops at Preset 3 (Batch)

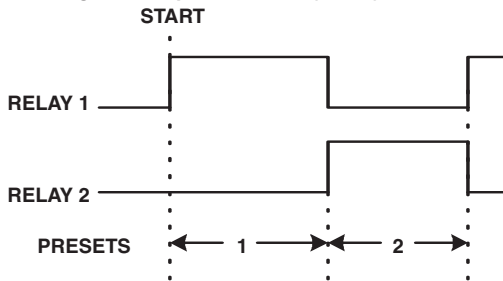

The Timer/Counter will repeat until it reaches the set count or time (Preset 3).

FLIP FLOP TIMER OR COUNTER WITH DWELL SIMILAR TO ATC (306) ACTION

Relay 1 energizes at start then has a dwell (Preset 3) Relay 2 then energizes and drops out. Cycle can repeat or cycle once.

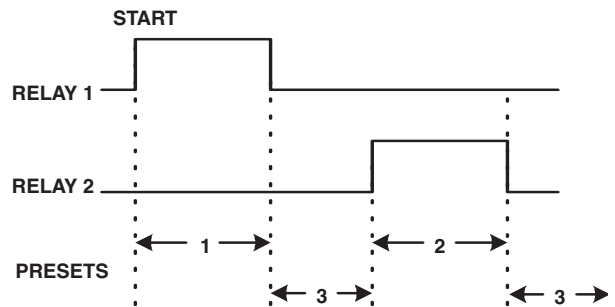

For a standard Flip-Flop timer / counter set Preset 3 to "0".

*Note: Relay arrangement 1 and 2 are shown in single cycle only, when used in repeat cycle the relationship between the relays changes, the process restarts after preset 2. The micro-

processor automatically calibrates the timer for 50 or 60Hz power operation, there are no switches or jumpers to set.

OPERATION

THE DISPLAY: A highly visible dual display consists of three digits with a movable decimal point or four digits for counting. There is a horizontal timing bar "—" which appears to the right of the upper display and blinks once per second during timing. This is very useful in showing that the timer is timing especially when the digits do not change rapidly as in the hours ranges. The timing bar blinks rapidly at time-out as well. The lower display is DIP switch selectable to display the preset time or counts for any one of the four presets, and the upper display will show that presets cycle progress.

UNDERSTANDING THE PRESETS: There are three programmable presets, Preset 1, Preset 2, and Preset 3. There is a totalizer for each mode of operation, this preset is designated Preset 4. This preset is for display only and increments a count at the end of each cycle, to reset the totalizer to zero you must go into programming mode (see DIP switches) and set all four digits to zero. Once the totalizer reaches 9999 it will go to E000, the maximum count is E999 which actually has a count value of 10999. When changing or setting a preset in run mode, the display will revert back to the running time after a button has not been used for 10 seconds.

FUNCTIONS: To use the 385 you must apply power to terminals 16 and 2, terminal 1 is the start/reset or momentary start input terminal. You must also apply voltage to terminal 15 (clock/count input) to start timing or place a count, if power is removed from terminal 15 when you are timing the 385 will stop where it is and continue when power is reapplied to terminal 15.

The 385 was designed to replace most of the functions of the ATC model 375. Most of these functions can be done with the relay arrangement 1 and 2 modes of operation. The arrangement 3 mode was not implemented, and most arrangement 3 applications can be done with the flip-flop mode of operation. The 385 can function as a ON-Delay or OFF-Delay timer or counter in arrangement 1, (ATC model 365B,366) to allow this, preset 1 and preset 3 must be set to 999 hours, the 385 will interpret this as infinite time and display as "INF". Preset 2 will be the set time and allow a setting of 999 hours. Relay 1 will act as an instantaneous relay, and Relay 2 as a delayed relay. The 385 when set as a standard timer operates in hours, minutes, and seconds with a movable decimal point, also the 385 can operate in hours:minutes and minutes:seconds with a maximum setting of 99:59 (see DIP switches).

NEW MODES OF OPERATION: The 385 can perform as a Flip-Flop timer or counter with batch. Preset 1 is the first set time and Preset 2 is the second set time. Preset 3 is the batch, which it stops at after a certain number of flip-flop cycles up to 999, or stops at any desired time. In this mode you cannot use the hours:minutes and minutes:seconds operation. The other new mode of operation is the Flip-Flop timer or counter with dwell. This is the mode to be used when a standard Flip-Flop is needed. This new mode is designed to have a first set time (Preset 1) then a dwell time (Preset 3) followed by the second set time (Preset 2), when used in repeat cycle there is a dwell after Preset 2 also. To use as a standard Flip-Flop set the dwell time to "0". All of the modes can be set for a voltage or no voltage start, momentary or sustained start, and repeat or single cycles.

WIRING

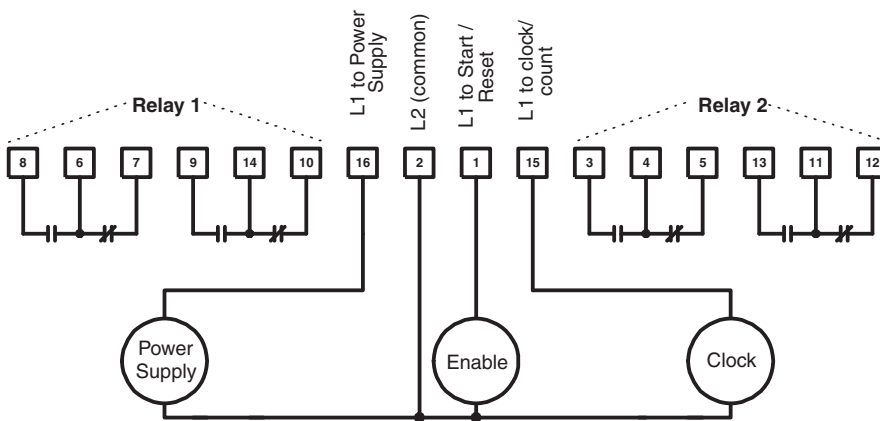

TERMINAL WIRING

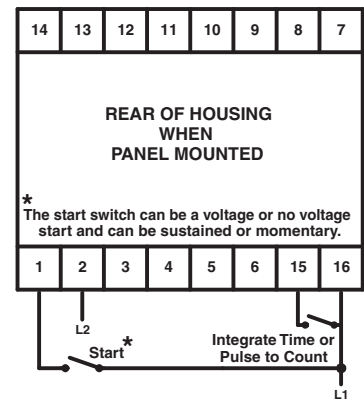



Multi-Function Multi-Range Timer

The **ATC 652** is a micro-processor-based timer with a 4-1/2 digit LCD display that can provide an indication of either preset time remaining or elapsed. There are five timing ranges covering time values from one millisecond to 199 hours 59 minutes. The unit has both an instantaneous relay output and a programmable relay output which can be programmed for any one of 14 different timing modes.

The timing range and mode are selected with an internal DIP switch. The time value is entered using the keypad on the front face. The programmed values are retained in memory and are secured in memory by a keypad lockout command. The keypad can also be used to perform secondary functions such as reset, immediate time out, time inhibit, changing the direction of the display, displaying the number of cycles run, and clearing the cycle counter.

The Model 652 is housed in a standard 15-terminal, plug-in, round case. Models are available for operation on either 120 VAC or 240 VAC.

- Five Time Ranges From 0.001 SEC
- Replaces Most Electro-Mechanical Timers
- Six Single-Cycle and Eight Repeat-Cycle Timing Modes
- Easy Programming 7/16" High LCD Display
- Sealed Faceplate
- Keypad Lockout of Time Setting
- Internal Cycle Counter
- Data Retention Memory with EEPROM Circuitry (652-8-2000, 652-8-2001 Models)
- Data Retention Memory with Lithium Battery (652-8-3000, 652-8-3001 Models)

DIMENSIONS (INCHES/MILLIMETERS)

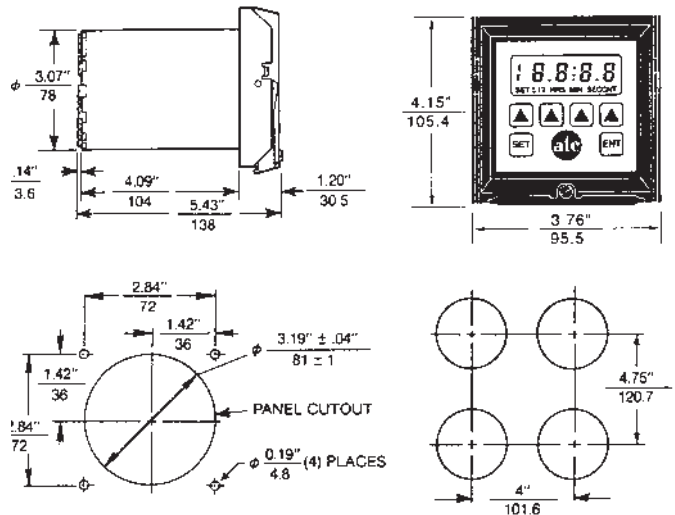

WIRING

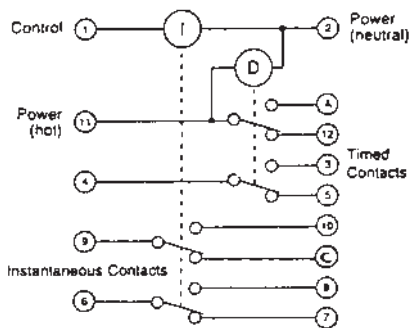

model 600-3-3950 surface mounting bracket

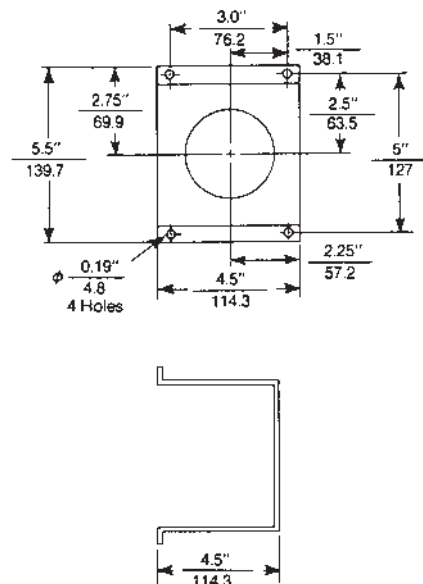

Panel Mounted Digital Timers // 652 Series

SPECIFICATIONS—ALL MODELS

TIMING RANGES	0.001 SEC to 19.999 SEC
	0.01 SEC to 199.99 SEC
	0.1 SEC to 1999.9 SEC
	1 SEC to 199 MIN 59 SEC
	1 MIN to 199 Hr. 59 MIN
RESET TIME	ON-Delay, Interval, Reverse Start Delay
	Reverse Start Interval, Momentary Start
	Accumulator, Repeat Cycle-OFF First
	Repeat Cycle-ON First, Repeat Cycle
	Reverse Start-OFF First, Repeat Cycle
	Reverse Start-ON First, Repeat Pulse
	Repeat Pulse, First Pulse Immediate
	Repeat Pulse-Reverse Start, Repeat Pulse,
	First Pulse Immediate Reverse Start
TIME SETTING	Front Panel Keypad
TIME REPEAT ACCURACY	±0.005 SEC
DISPLAY	LCD - 4 1/2 Digit, 7/16" High
RELAY MECHANICAL LIFE	50,000,000 Operations
INSTANTANEOUS RELAY OUTPUT	7 Amps Resistive, 240 VAC, 2 N.O.
	2 N.C. Contact
TIMED RELAY OUTPUT	7 Amps Resistive, 240 VAC, 2 N.O.
	2 N.C. Contact
TEMPERATURE RATING	32° - 140°F (0° - 60°C)
OPERATING POWER	120 or 240 VAC, +10%, -20%, 50/60 Hz
TRANSIENT VOLTAGE PROTECTION	Metal Oxide Varistor
NEMA RATING	NEMA 12
TERMINALS	Screw Terminals
MOUNTING	Plug In Case
WEIGHT	Net: 25 oz.
	Shipping: 30 oz.

SPECIFICATIONS – 652-8-2000 & 652-8-2001

RESET TIME	25 mSEC
CONTROL VOLTAGE INITIATE TIME	25 mSEC
MEMORY	EEPROM Circuitry
POWER CONSUMPTION	5.2 VA

SPECIFICATIONS – 652-8-3000 & 652-8-3001

RESET TIME	8 mSEC
CONTROL VOLTAGE INITIATE TIME	8 mSEC
MEMORY	Lithium Battery
POWER CONSUMPTION	3.7 VA

ORDERING INFORMATION

MODEL NUMBER	DESCRIPTION
652-8-2000	Plug-in, Round Case Timer 120 VAC W/EEPROM Memory
652-8-2001	Plug-in, Round Case Timer 240 VAC W/EEPROM Memory
652-8-3000	Plug-in, Round Case Timer 120 VAC W/Battery Memory
652-8-3001	Plug-in, Round Case Timer 240 VAC W/Battery Memory
651-3-0128	Mounting Gasket, 1/8" Thick (Included With Timer)
651-3-0129	Mounting Gasket, 1/4" Thick (Included With Timer)
600-3-3950	Base Mounting Bracket
652-3-0130	Replacement Lithium Battery (For -3000, -3001 Models)



The **ATC 653** is a micro-processor-based control that can function as either a timer or a counter. It has a 4-1/2 digit LCD that can provide an indication of either the time or count value remaining or elapsed. There are five timing ranges covering time values from one millisecond to 199 hours 59 minutes. There are also three count speeds to a maximum of 7500 counts per second. The unit has an instantaneous relay output and a programmable relay output which can be programmed for any one of 14 different timing modes.

The timing range, count speed and timing mode are programmed with an internal DIP switch assembly. An external switch determines whether the time inhibit or count input takes place with application or removal of voltage. The time or count value is preset by the operator using the keypad on the front face.

These programmed values are retained in memory and are secured in memory by a keypad lockout command. The keypad can also be used to perform secondary functions such as reset, immediate time/count out, time/count inhibit, changing the direction of the display, displaying the number of cycles run, and clearing the cycle counter.

The Model 653 is housed in a standard 15-terminal plug-in round case. Models are available for operation on either 120 VAC or 240 VAC. Counting can be done at either line voltage or at 12-48 VDC/24 VAC.

Multi-Function Multi-Range Solid-State

- Functions As Timer or Counter
- Five Time Ranges
- Six Single-Cycle and Eight Repeat-Cycle Timing Modes
- Sealed Faceplate
- Cycle Counter
- Count Input Scaling
- Data Retention Memory with EEPROM Circuitry. (653-8-2000, 653-8-2001 Models)
- Data Retention Memory with Lithium Battery (653-8-3000, 653-8-3001 Models)

DIMENSIONS (INCHES/MILLIMETERS)

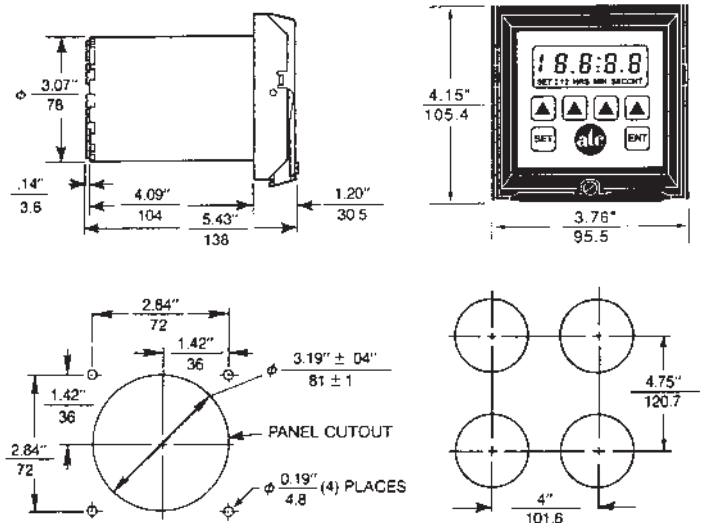

WIRING

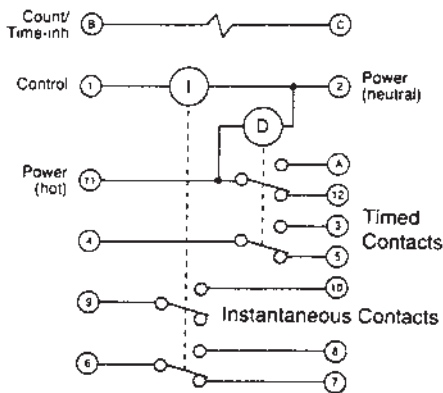

model 600-3-3950 surface mounting bracket

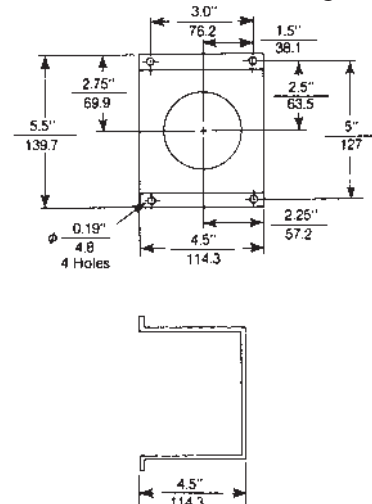

SPECIFICATIONS—ALL MODELS

TIMING RANGES	0.001 SEC to 19.999 SEC
	0.01 SEC to 199.99 SEC
	0.1 SEC to 1999.9 SEC
	1 SEC to 199 MIN 59 SEC
	1 MIN to 199 Hr. 59 MIN
RESET TIME	ON-Delay, Interval, Reverse Start Delay
	Reverse Start Interval, Momentary Start
	Accumulator, Repeat Cycle-OFF First
	Repeat Cycle-ON First, Repeat Cycle
	Reverse Start-OFF First, Repeat Cycle
	Reverse Start-ON First, Repeat Pulse
	Repeat Pulse, First Pulse Immediate
	Repeat Pulse-Reverse Start, Repeat Pulse
First Pulse Immediate Reverse Start	
TIME SETTING	Front Panel Keypad
TIME REPEAT ACCURACY	Count: 100% Time: ±0.005 SEC
DISPLAY	LCD: 4-1/2 Digit, 7/16" High
RELAY MECHANICAL LIFE	50,000,000 Operations
INSTANTANEOUS RELAY OUTPUT	7 Amps Resistive, 240 VAC, 2 N.O.
	1 N.C. Contact
TIMED RELAY OUTPUT	7 Amps Resistive, 240 VAC, 2 N.O.
	2 N.C. Contacts
TEMPERATURE RATING	32° - 140°F (0° - 60°C)
OPERATING POWER	120 or 240 VAC, +10%, -20%, 50/60 Hz
TRANSIENT VOLTAGE PROTECTION	Metal Oxide Varistor
NEMA RATING	NEMA 12
TERMINALS	Screw Terminals
MOUNTING	Plug In Case
WEIGHT	Net: 25 oz.
	Shipping: 30 oz.

SPECIFICATIONS – 653-8-2000 & 652-8-2001

RESET TIME	25 mSEC
CONTROL VOLTAGE INITIATE TIME	25 mSEC
MEMORY	EEPROM Circuitry
POWER CONSUMPTION	5.2 VA
INSTANTANEOUS RELAY OUTPUT	7 Amps Resistive, 240 VAC, 2 N.O., 2 N.C. Contacts

SPECIFICATIONS – 653-8-3000 & 652-8-3001

RESET TIME	8 mSEC
CONTROL VOLTAGE INITIATE TIME	8 mSEC
MEMORY	Lithium Battery
POWER CONSUMPTION	3.7 VA
INSTANTANEOUS RELAY OUTPUT	7 Amps Resistive, 240 VAC, 2 N.O., 2 N.C. Contacts

ORDERING INFORMATION

MODEL NUMBER	DESCRIPTION
653-8-2000	Plug-in, Round Case Timer 120 VAC W/EEPROM Memory
653-8-2001	Plug-in, Round Case Timer 240 VAC W/EEPROM Memory
653-8-3000	Plug-in, Round Case Timer 120 VAC W/Battery Memory
653-8-3001	Plug-in, Round Case Timer 240 VAC W/Battery Memory
651-3-0128	Mounting Gasket, 1/8" Thick (Included With Timer)
651-3-0129	Mounting Gasket, 1/4" Thick (Included With Timer)
600-3-3950	Base Mounting Bracket
652-3-0130	Replacement Lithium Battery (For -3000, -3001 Models)



Panel Mounted Digital Timer

- Direct Replacement For Electromechanical Timers
- Two Timing Modes
- Data Retention with EEPROM Memory or Battery
- Five Time Ranges
- Simple Keypad Time Setting
- Sealed Faceplate
- Keypad Lockout of Time Setting
- Easy Programming
- Instantaneous Contacts Directly Track the Control Input

ORDERING INFORMATION

MODEL NUMBER	DESCRIPTION
655-8-1000	Timer 120VAC W/EEPROM Memory
655-8-1001	Timer 240VAC W/EEPROM Memory
655-8-3000	Timer 120 VAC W/Battery Memory
655-8-3001	Timer 240 VAC W/Battery Memory
655-8-3000	Timer 120 VAC W/Battery Memory
655-8-3001	Timer 240 VAC W/Battery Memory
652-3-0130	Replacement Lithium Battery
600-3-3950	Base Mounting Bracket
651-3-0128	Mounting Gasket, 1/8" Thick (Included with Timer)
651-3-0129	Mounting Gasket, 1/4" Thick (Included with Timer)

The **ATC Model 655** timer is an electronic control that will retrofit most round case electromechanical timers. The control performs the same timing modes (ON-Delay or Reverse Start Delay) as electromechanical units, and it is capable of timing ranges from 1 millisecond to 199 hours, 59 minutes. On the bottom inside of the control are DIP switches which can be set, in seconds, to establish the timing mode and time range. Our unit will plug into competitive mounted cases without wiring changes in most instances. Remove the electromechanical timer, set ours, plug it into the electromechanical timer case and you're ready to run. DIP switch setting instructions for electromechanical timers are supplied with 655 installation instructions.

DIMENSIONS (INCHES/MILLIMETERS)

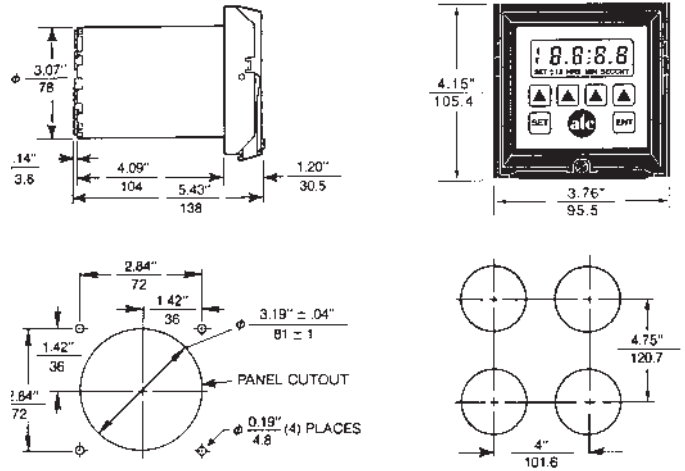

model 600-3-3950 surface mounting bracket

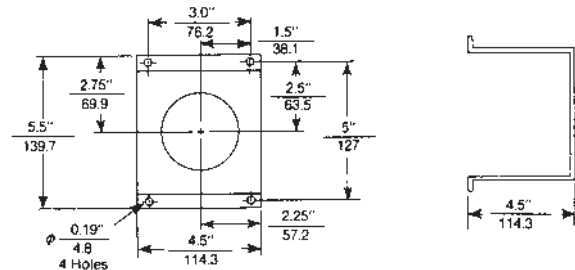

WIRING

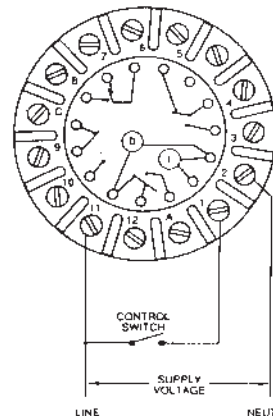

internal schematic

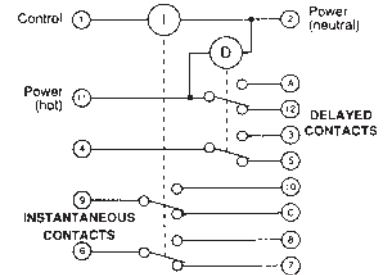

DIP SWITCH SETTING GUIDE

Eagle Part Number	A655 Switch Settings						
	1	2	3	4	5	6	7
HP50A6	O	O	X	O	O	O	O
HP50A601	O	O	X	O	O	X	O
HP51A6	O	O	X	O	O	O	O
HP51A601	O	O	X	O	O	X	O
HP52A6	O	X	O	O	O	O	O
HP52A601	O	X	O	O	O	X	O
HP53A6	O	X	X	O	O	O	O
HP53A601	O	X	X	O	O	X	O
HP54A6	O	X	X	O	O	O	O
HP54A601	O	X	X	O	O	X	O
HP55A6	O	X	X	O	O	O	O
HP55A601	O	X	X	O	O	X	O
HP56A6	O	X	X	O	O	O	O
HP56A601	O	X	X	O	O	X	O
HP57A6	O	X	X	O	O	O	O
HP57A601	O	X	X	O	O	X	O
HP58A6	X	O	O	O	O	O	O
HP58A601	X	O	O	O	O	X	O
HP59A6	X	O	O	O	O	O	O
HP59A601	X	O	O	O	O	X	O
HP510A6	X	O	O	O	O	O	O
HP510A601	X	O	O	O	O	X	O
HP511A6	X	O	O	O	O	O	O
HP511A601	X	O	O	O	O	X	O
HP514A6	O	O	X	O	O	O	O
HP514A601	O	O	X	O	O	X	O
HP515A6	O	O	X	O	O	O	O
HP515A601	O	O	X	O	O	X	O
HP517A6	O	O	X	O	O	O	O
HP517A601	O	O	X	O	O	X	O
HP518A6	O	X	X	O	O	O	O
HP518A601	O	X	X	O	O	X	O

DIP SWITCH DEFINITIONS

O=OFF X=ON

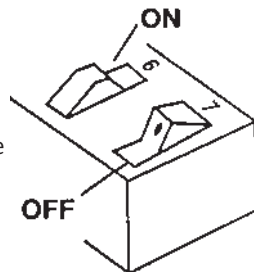

- Determine Eagle Model Number:** To determine the Model Number of the Eagle HP5; remove timer from case by loosening the screw at the lower front of the timer face and lift the mounting handle and pull the timer from the case. The model number will be on the left side of the timer. Some models will have a metal plate with the part number, others have a label with the number in that same area.
- Remove Control:** Remove the 655 control from its case by loosening the screw at the bottom of the chrome handle, lifting the handle up and pulling the control forward.
- Determine Switch Settings:** Determine how the 655 DIP switches should be set to retrofit that particular HP5 model using the DIP Switch Setting Guide.
- Set Time Base:** Hold the control to expose the DIP switch assembly on the bottom of unit and set the time base you require on switches 1, 2, and 3.

SPECIFICATIONS—ALL MODELS

TIMING RANGES	0.001 SEC to 19.999 SEC
	0.01 SEC to 199.99 SEC
	0.1 SEC to 1999.9 SEC
	1 SEC to 199 MIN 59 SEC
	1 MIN to 199 Hr. 59 MIN
TIMING MODES	ON-Delay or Reverse Start Delay
RESET TIME	25 mSEC
CONTROL VOLTAGE INITIATE TIME	25 mSEC
MEMORY	Lithium Battery - Replaceable
POWER CONSUMPTION	5.2VA
TIME SETTING	Front Panel Keypad
TIME REPEAT ACCURACY	± .005 SEC
DISPLAY	LCD: 4-1/2 Digit, 7/16" High
RELAY MECHANICAL LIFE	50,000,000 Operations
INSTANTANEOUS RELAY OUTPUT	7 Amps Resistive, 240 VAC 2 N.O., 2 N.C. Contacts
SHORT CIRCUIT PROTECTION	1/4 Amp Fuse
TEMPERATURE RATING	32° to 140°F (0° to 60°C)
OPERATING POWER	120 or 240 VAC, +10%, -20%, 50/60 Hz.
TRANSIENT VOLTAGE PROTECTION	Metal Oxide Varistor
NEMA RATING	NEMA 12
TERMINALS	Screw Terminals
MOUNTING	Plug In Case
WEIGHT	Net: 25 oz. Shipping: 30 oz.

- Set Timing Mode:** To select the timing mode required, set switches 5, 6, and 7 on the switch assembly as recommended by the DIP Switch Setting Guide.
- Set Preset Time:** Position the 655 control so that you are looking at the keypad on the front of the unit. Push the SET button and four dashes will appear. Depress the SET button a second time and word SET and four zeros will appear. To enter the preset time desired, press the ENT button and preset number will flash seven and go blank. The Model 655 timer is now ready to operate and can be returned to its case or directly into the case of the HP5 that it is replacing. To check or change the preset time; push the SET button and time setting will be displayed. To change the preset time follow the same procedure as indicated previously in this paragraph. When you have completed setting a new preset time, push the ENT button. The preset time can be changed when the 655 is running a cycle or "on the fly". That run cycle will be completed based on the preset at the beginning of the cycle. The new preset will control the next cycle.

NOTE: If the "SET" button is pushed to review or change the preset time, the ENT button must be pushed to return the control to the operating mode.



The **ATC 765** Step Controller is the perfect alternative to cam timers and micro PLC's for simple sequential applications. The 765 is a powerful, compact, economical sequential control that features an extremely user friendly programming format.

Microprocessor-based, it offers 100 control levels or steps, 8 programmable relay outputs, functions with count input signals or timed input with 4 timing range values from 0.01 seconds to 99 hours/59 minutes and a host of other primary and secondary keypad functions.

A cost-effective control, the Model 765 is an ideal alternative to cam timers and micro PLCs for sequencing operations. Equipped with EEPROM memory, the Model 765 can store programmed information indefinitely, without battery back-up, freeing PLCs from memory storage that can be better applied for more critical data retention tasks. It step advances on the basis of time or count which can be intermixed from one control step to the next if desired.

Sealed for the harsh industrial environment, the Model 765 is equally at home in the laboratory for quality control or test applications.

Programmable Count/Time Step Control

- 1 Sequence—Up to 100 Steps
- 8 User-Defined Outputs
- Multiple Timing Ranges
- Time and/or Count Step Advance Modes
- 120VAC and 240VAC Models
- Easy to Configure
- Membrane Keypad/Panel Gasket Resist Industrial Environments
- Keypad Lockout
- Large 9/32" Digital LCD Readout
- Four-Point Screw Mounting Resists Vibration

DIMENSIONS (INCHES/MILLIMETERS)

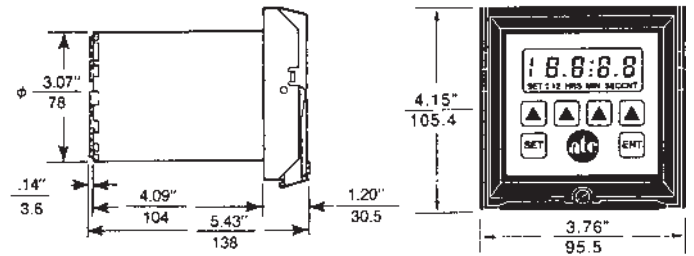

WIRING

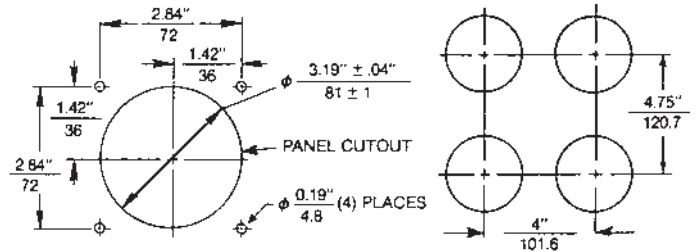
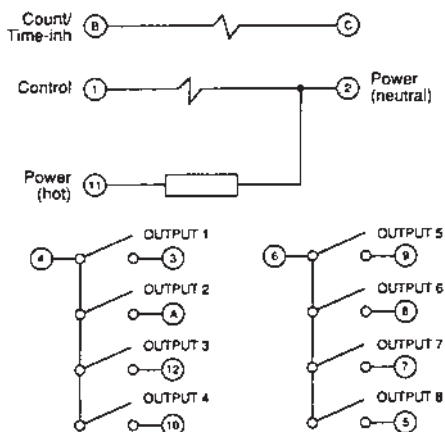

model 600-3-3950—surface mounting bracket

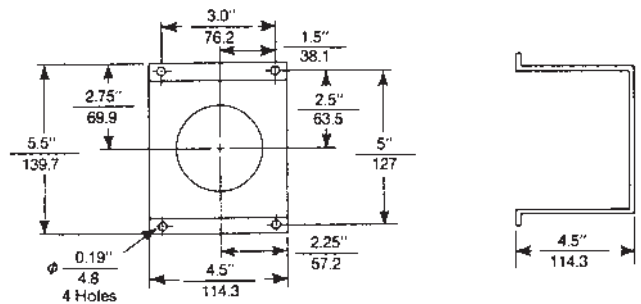

SPECIFICATIONS—ALL MODELS

TIMING RANGES	0.001 SEC to 19.999 SEC	
	0.01 SEC to 199.99 SEC	
	0.1 SEC to 1999.9 SEC	
	1 SEC to 199 MIN 59 SEC	
	1 MIN to 199 Hr. 59 MIN	
COUNT RANGE	9999	
COUNT INPUT/TIME INHIBIT	Line Voltage or 12-18 VDC, 24 VAC	
COUNT SPEEDS (AC OR DC)	500/MIN 5000/MIN	
MEMORY	EEPROM	
POWER CONSUMPTION	5.2VA	
TIME SETTING	Front Panel Keypad	
REPEAT ACCURACY	Count	100%
	Time	±0.01 SEC Max.
MECHANICAL LIFE	50,000,000 Operations	
OUTPUT	8 Relay Contacts, N.O.	
	Ratings	5A/250V/1250VA Max. Resistive 2A/250V/500VA Max. Inductive
TEMPERATURE RATING	32° to 140°F (0° to 60°C)	
POWER CONTROL INPUT	Voltage	120 or 240VAC
	Power Consumption	3.2VA
	Frequency	50/60 Hz.
	Range	20% to +10% Nom.
TRANSIENT VOLTAGE PROTECTION	Metal Oxide Varistor	
WEIGHT	1.64 lb.	

MODEL NUMBER >>>>>>	765	8	
Operating Voltage			
	120 VAC		1000
	240 VAC		1001
ACCESSORIES			
600-3-3950 Base Mounting Bracket:			
651-3-0128 Panel Gasket 1/8" Thick (Included with Controller)			
651-3-0129 Panel Gasket 1/4" Thick (Included With Controller)			

LCD DISPLAY

The front panel display provides indication of; step number, time or count value and output status when the unit's in the run mode; and programming information when in the program mode. The membrane keys provide input command access to generate the desired program mode sequence, as well as intervene in the run mode sequence.

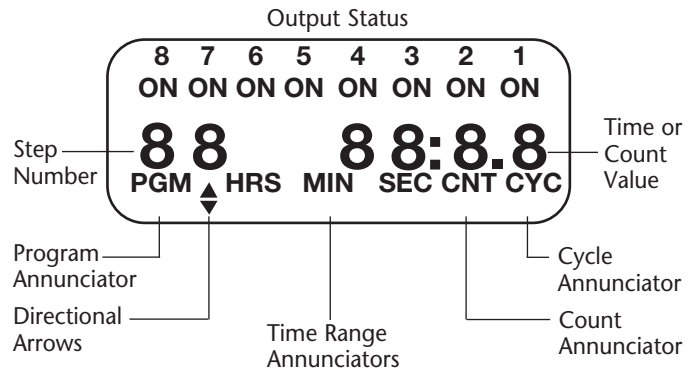

OUTPUT STATUS: Indication of the "on" or "off" state of each output in both the program and run modes.

STEP NUMBER: Indication from "H" (Home) through "99".

PROGRAM ANNUNCIATOR: Illuminates in the program mode.

DIRECTIONAL ARROWS: In run mode, they indicate the direction of timing or counting, i.e., from the setpoint to zero or from zero to the setpoint. In program mode, they indicate the direction of manual stepping with the STEP key.

TIME RANGE ANNUNCIATORS: In run mode, they indicate the time range being executed on each step. In program mode, they indicate the time range that has been or will be programmed. Note that the SEC annunciator (when used by itself) is associated with two different time ranges depending on the position of the decimal point.

TIME OR COUNT VALUE: Four-digit indication of the programmed value in the program mode or the actual value in the run mode.

CYCLE ANNUNCIATOR: Illuminates in both program and run modes when the value of the cycle counter is being displayed.

COUNT ANNUNCIATOR: Illuminates in both program and run modes when step advance is to take place on the basis of a count value.



Preset Counter/Timer

- 4 Digit LED Display
- Count Up, Down, or Up/Down Selectable
- Universal 100-240VAC
- Relay and Solid-State Output
- Selectable as Counter or Timer Control
- Lithium Battery Memory—10 Years

ORDERING INFORMATION

FX4S *A single model number is required for ordering.*

DIMENSIONS (INCHES/MILLIMETERS)

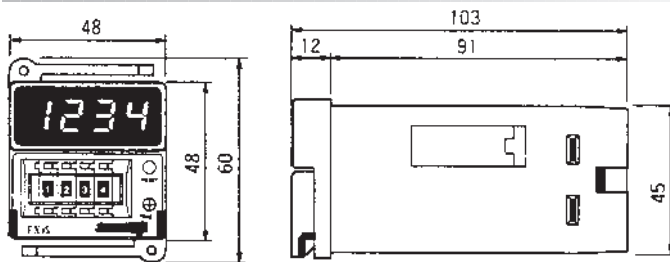

WIRING

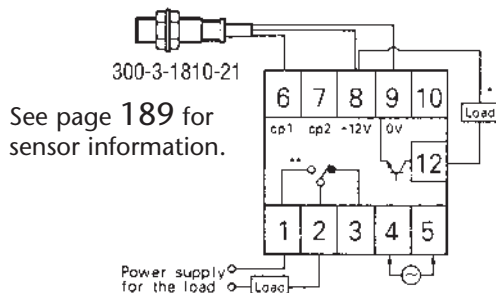

The **FX4S** is a single level preset counter or timer control with two (2) outputs, a 3A at 240VAC relay and a 100mA max. at 30VDC max. NPN open collector transistor. A series of ten (10) DIP switches located on the side of the unit are used to select the output mode required, memory retention on power down, count speed, timer or counter selection, Up/Down mode, input counter mode and timer time base. The front panel features pushbutton switches for preset and an LED display showing time or count.

The FX4S is housed in a compact 1/16 DIN enclosure that requires only 48mm² front panel space and less than four (4) inches behind the panel. The FX4S is a cost effective, accurate, simple to set, reliable control.

SPECIFICATIONS—ALL MODELS

NUMBER OF DIGITS	Four	
NUMBER OF CONTROL PRESETS	One	
OPERATING POWER	100 to 240VAC, 50/60 Hz.	
POWER CONSUMPTION	4VA	
OUTPUTS	1 SPDT Form C Relay; 3A @ 250VAC	
	1 solid-state NPN Open Collector, Transistor Max. 30VDC; Max. 100mA	
	Latch Output Until Reset—Time/Count Value Continues Until Reset	
	Latch Output & Time/Count Value Until Reset	
OUTPUT MODES	Auto Reset at Start of One Shot Output	
	Auto Reset at Completion of One Shot Output	
	One Shot Output—Time/Count Value Continues Until Reset	
	One Shot Output—Auto Reset of Time/Count Value at Start of One Shot—Auto	
COUNT/RESET INPUTS	Reset of Display at Completion of One Shot	
	One Shot Output—Auto Reset at Completion of One shot— Time/Count Value	
	Continues Until Auto Reset	
	Counter Mode Only—Output is ON Only When Actual Count Value Exceed "SET" Value	
MEMORY	Time Mode Only—Symmetrical Repeat Cycle Timer Beginning With "OFF Time"	
	Isolated Contact	
RESET	Transistor (NPN or PNP Selectable)	
PRESET METHOD	Lithium Battery	
ONE SHOT TIME	Pushbutton Switches—Front Panel	
POWER FOR SENSOR	Front Panel Button or Remote Switch Closure	
TERMINATION	0.07 to 3 SEC Adjustable	
FRONT PANEL DISPLAY	12 VDC \pm 10%, 50mA	
MOUNTING	Rear Mounted Screw Terminals	
WHEN USED AS A TIMER	Count/Time Value Red LED	
	Time UP or Time DOWN	
	0—99.99 SEC	0—999.9 SEC
	0—9999 SEC	0—99 Min., 59 SEC
TIME RANGES	0—999.9 MIN	0—99 Hr., 59 MIN
	0—999.9 Hour	0—9999 Hour
WHEN USED AS A COUNTER		
COUNT SPEED	Selectable — 30 cps or 2000 cps	
COUNT MODES	Count Up, Count Down, or Count Up/Down	
OPERATING TEMPERATURE	14° to 131°F (-10 to +55°C)	
WEIGHT	.40 lb.	